

INDEPENDENTLY-MOUNTED V-DRIVE INSTALLATION

WALTER V-DRIVE

• EST. 1927 •

INSTALLATION & SERVICE MANUAL

-- Models RV-10 & RV-10D thru RV-50 & RV-50D --

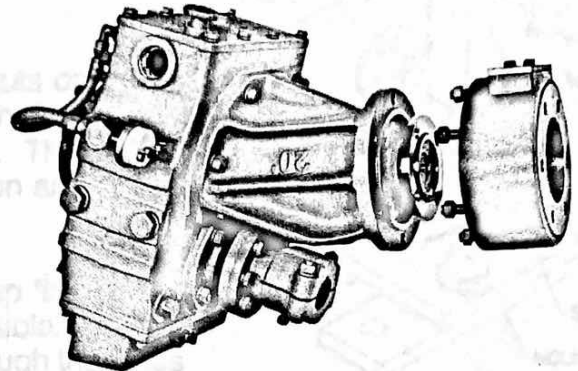
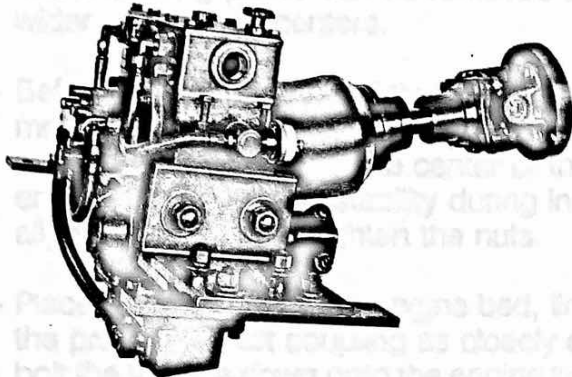

WARNING !!! Do not touch V-Drive or related components until all shafts and exposed parts are stopped, the ignition is off, the battery is disconnected, and the propeller shaft is locked. All repairs and maintenance must be done by a skilled mechanic. No work should be performed unless the mechanic is equipped with steel-tipped shoes and protective eyeglasses or goggles. Other sensible precautions should also be taken.

<u>PAGE #</u>	<u>CONTENTS</u>
1	Independently-Mounted V-Drive Installation
3	Directly-Mounted V-Drive Installation
3	Installation of Water & Switch Connections
4	Oil Fill
5	Alignment Instructions
7	Troubleshooting Guide
10	Disassembly & Reassembly Instructions
13	Pump Assembly Instructions
14	Torque Specifications
15	V-Drive Maintenance
16	Independently-Mounted General Assembly Print
18	Directly-Mounted General Assembly Print

THE WALTER MACHINE COMPANY, INC.
84-100 CAMBRIDGE AVENUE
JERSEY CITY, N.J. 07307

TEL: (201) 656-5654

FAX: (201) 656-0318

WARRANTY AUTHORIZATION: All warranty work must be authorized by the factory before being performed. Consult W.M.C. with the V-Drive serial number and model number to be given a warranty authorization number. No warranty claim can be honored if prior authorization has not been given.

INDEPENDENTLY-MOUNTED V-DRIVE INSTALLATION

ADJUSTABLE MOUNTING BRACKETS

All Independently-Mounted V-Drives are supplied with #16 3-way Adjustable Mounting Brackets (2-way on the RV-10) as standard equipment.

- The brackets should face downward as shown in FIG. 1.
- The mounting plates can be removed and reversed to fit wider engine bed centers.
- Before installing the V-Drive, loosen all the nuts on the mounting brackets and position each part of the brackets so that the studs are in the center of the slots. This will ensure maximum adjustability during installation and alignment. Then, re-tighten the nuts.
- Place the V-Drive on the engine bed, lining it up "by eye" to the propeller shaft coupling as closely as possible. Firmly bolt the V-Drive down onto the engine bed through the holes provided in the mounting plates.
- Loosen the locking nuts on the adjusting screws (SEE FIG. 1). Slightly loosen the nuts on the mounting brackets just enough to be able to move the V-Drive during alignment.

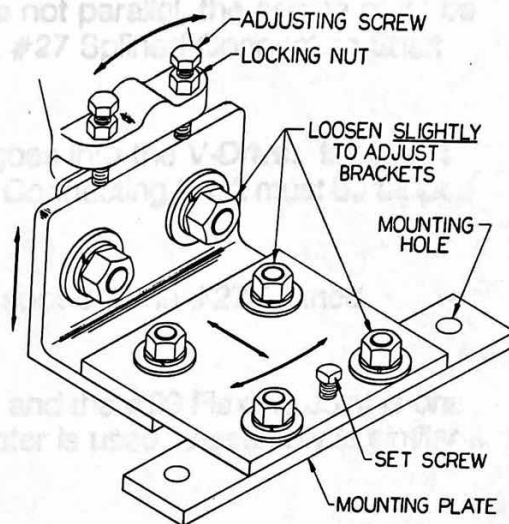

FIG. 1

DRIVE SYSTEM ASSEMBLY

All Independently-Mounted V-Drives are connected to the transmission by means of a "floating" shaft assembly which eliminates strain between the engine, the V-Drive, and the propeller shaft. By using a self-aligning bearing in the front of the V-Drive along with a splined shaft and flexible joint, the shaft can move in and out and also angularly to take up slight engine misalignment (3 degrees maximum). The #39, #39A Flexible Joint Assembly is used in short installations whereas the #36 Adjustable Tubular Shaft is used in long installations.

- After the V-Drive has been aligned with the propeller shaft (SEE V-DRIVE ALIGNMENT INSTRUCTIONS, PAGE 5), the #27 Splined Connecting Shaft must be cut to suit the installation (for short installations with #39, #39A Flexible Joint Assembly only). The shaft should be cut on the end with the keyway.
- After cutting, tap the #27 Splined Connecting Shaft into the #39A Flexible Joint Flange (for short installations) or #36 Adjustable Tubular Shaft (for long installations), but do not tighten the set screw.
- Slip the #27 Splined Connecting Shaft into the internal spline of the V-Drive to the proper "AH" Depth (SEE CHART in FIG. 2). Wrap a piece of tape around the shaft at the proper length before installation to ensure the correct length of the shaft going into the V-Drive. If the shaft does not go into the V-Drive far enough, the spline of the shaft can ride on the #24A Oil Seal and/or #24E O-Ring and an oil leak may develop. If the shaft goes into the V-Drive too far, it will preload the #26 Self-Aligning Bearing and may cause premature failure of this bearing.

SHORT INSTALLATIONS WITH #39, #39A FLEXIBLE JOINT ASSEMBLY (SEE FIG. 2)

- Bolt the #40 Disc Adapter to the transmission output flange.
- Install the #39 Flexible Joint between the #39A Flexible Joint Flange and the #40 Disc Adapter and bolt it in place.
- If the pilot diameters do not engage freely or if the faces are not parallel, the engine must be preliminarily adjusted. Failure to do so may result in a bent #27 Splined Connecting Shaft and/or internal damage to the V-Drive.
- Recheck the depth that the #27 Splined Connecting Shaft goes into the V-Drive. If it is not correct, the assembly must be removed and the #27 Splined Connecting Shaft must be tapped into or out of the #39A Flexible Joint Flange as required.
- Remove the set screw from the #39A Flexible Joint Flange, spot drill the #27 Splined Connecting Shaft, and replace and tighten the set screw.
- NOTE: On the RV-10 V-Drive, the #39A Flexible Joint Flange and the #39 Flexible Joint is one piece. Instead of the #40 Disc Adapter, a #33A Spool Adapter is used. Assembly is similar to the LONG INSTALLATION procedure below.

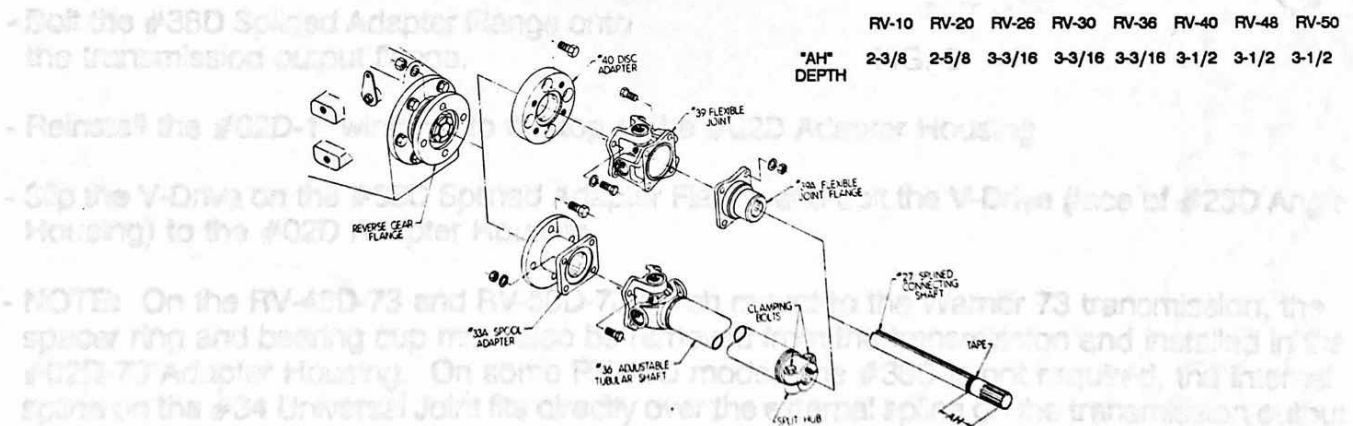

FIG. 2

LONG INSTALLATIONS WITH THE #36 ADJUSTABLE TUBULAR SHAFT (SEE FIG. 2)

- After inserting the #27 Splined Connecting Shaft into the split hub of the #36 Adjustable Tubular Shaft, tighten the two clamping bolts.
- Remove the #24 Angle Housing Cover Assembly from the V-Drive and insert the #27 Splined Connecting Shaft (with #36 Adjustable Tubular Shaft attached) through the #24 Angle Housing Cover and into the internal spline in the V-Drive.
- Reinstall the #24 Angle Housing Cover to the V-Drive.
- Bolt the #33A Spool Adapter between the transmission output flange and the flexible joint on the #36 Adjustable Tubular Shaft.
- Check the flange engagement and the "AH" dimension as described above.

DIRECTLY-MOUNTED V-DRIVE INSTALLATION

V-DRIVE ASSEMBLY TO TRANSMISSION (SEE FIG. 3)

- Loosen the locknut on the output shaft of the transmission and unbolt the transmission output flange (SEE FIG. 3). Next, remove the back cover from the transmission.
- Bolt the #02D Adapter Housing to the back of the transmission (where the back cover was removed). The back cover from the transmission is no longer required.
- Reinstall the transmission output flange to the transmission and secure with the locknut.
- Remove the #02D-1 "window" from the top of the #02D Adapter Housing for wrench access.
- Bolt the #38D Splined Adapter Flange onto the transmission output flange.
- Reinstall the #02D-1 "window" to the top of the #02D Adapter Housing.
- Slip the V-Drive on the #38D Splined Adapter Flange and bolt the V-Drive (face of #23D Angle Housing) to the #02D Adapter Housing.
- NOTE: On the RV-48D-73 and RV-50D-73 which mount to the Warner 73 transmission, the spacer ring and bearing cup must also be removed from the transmission and installed in the #02D-73 Adapter Housing. On some RV-10D models the #38D is not required; the internal spline on the #34 Universal Joint fits directly over the external spline on the transmission output shaft.

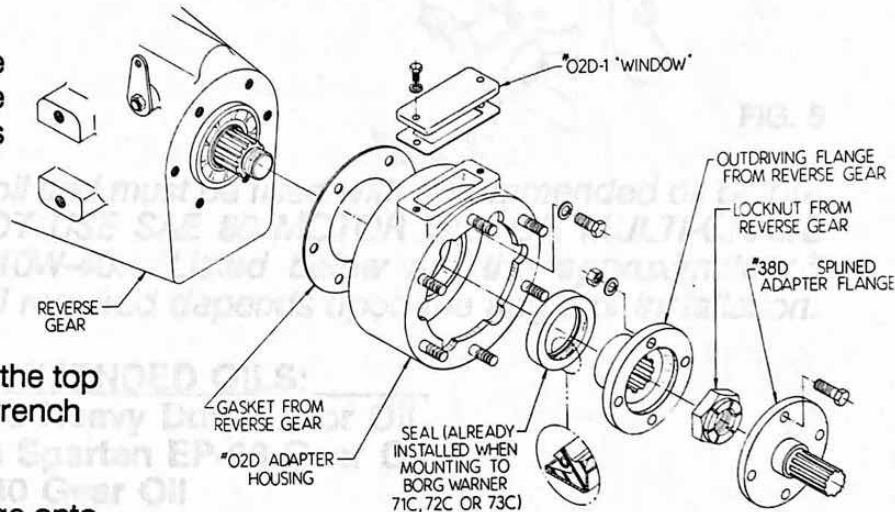

FIG. 3

INSTALLATION OF WATER AND SWITCH CONNECTIONS

WATER CONNECTIONS: (SEE FIG. 4) The models RV-20 thru RV-50 V-Drives are equipped with water-jacket cooling. On either side of the #01C Main Housing (near the top) are standard pipe-threaded holes. Either hole can be hooked up to intake side. The V-Drive should be cooled with raw water directly after it goes through the sea strainer; the V-Drive cannot be cooled after the engine jacket or engine heat exchanger. Normal operating temperature should be less than 180 degrees, although safe intermittent operating temperature may be as high as 210 degrees. Any silt, sand, or scale in the water-jacket of the #01C Main Housing should be cleaned out at the start of each season. Simply remove the #19A Cap Screws and lift off the #6D-C Top Cover to gain access to the water-jacket.

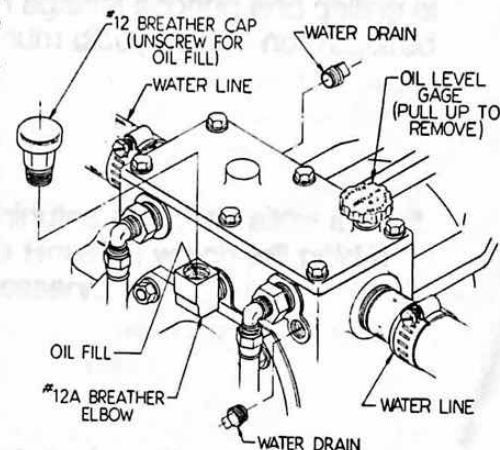

FIG. 4

SWITCH CONNECTIONS: (SEE FIG. 5) On all V-Drives equipped with an oil circulating pump, the #49 Oil Pressure Drop Switch and the #49A Warning Light (12 Volt) should be hooked up according to the wiring diagram on the print on PAGE 16. The switch may be grounded to any part of the V-Drive or the engine (either terminal may be used for the ground).

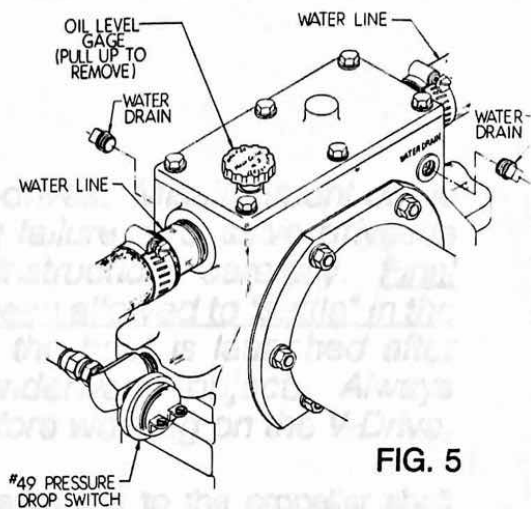

FIG. 5

OIL FILL

The V-Drive is shipped without oil and must be filled with recommended oil before operation (See below). **DO NOT USE SAE 80 MOTOR OIL, OR MULTI-GRADE OILS SUCH AS 10W-30 OR 10W-40.** Listed below are the approximate oil capacities; actual quantity of oil required depends upon the angle of installation.

RECOMMENDED OILS:

SAE 30 Heavy Duty Motor Oil
Exxon Spartan EP-68 Gear Oil
APG-80 Gear Oil

RV-10 RV-10D	RV-20 RV-20D	RV-26 RV-26D	RV-30 RV-30D	RV-36 RV-36D	RV-40 RV-40D	RV-48 RV-48D	RV-50 RV-50D
1 PINT	2 PINTS	2 PINTS	3 PINTS	3 PINTS	4 PINTS	4 PINTS	5 PINTS

- Pull out #21 Oil Level Gage (SEE FIG. 4).
- Unscrew the #12 Breather Cap and fill the V-Drive with suitable oil (see above) through the #12A Breather Elbow. The oil may also be filled through the hole for the #21 Oil Level Gage. On the RV-10D only, oil can be added by removing the plug in the top of the main housing.
- The oil level should be checked with the #21 Oil Level Gage fully inserted in the unit. The proper level is between the "H" and "L" marks on the gage.
- For extra lubrication during initial break-in, add the molybdenum disulphide (provided in a small bottle) into the oil. Molybdenum disulphide provides protection against scoring and galling of gears, bearings, and other moving parts. Additional molybdenum disulphide is not required after the initial break-in, although it is recommended.
- Reinstall the #12 Breather Cap and #21 Oil Level Gage.
- Connect the battery and run the V-Drive for approximately 2 minutes and then allow it to sit for 1 minute. This will ensure oil circulating into the #23 Angle Housing which will hold a small amount of oil. Recheck oil level and add more oil if necessary.

FLEX-JOINT LUBRICATION

On Independently-Mounted V-Drives only, the zerk fitting (on the cross of the external U-Joint) must be greased with a light alemite lubricant (SEE FIGS. 7 - 9).

V-DRIVE ALIGNMENT INSTRUCTIONS

WALTER V-Drives are precision built, heavy duty gear-drives. Misalignment of the engine or the V-Drive can cause oil seal and bearing failure, excessive driveline vibration, and noisy operation. Please follow these instructions carefully. Final alignment should not be attempted until the boat has been allowed to "settle" in the water. Realignment should be performed whenever the boat is launched after being hauled from the water or after striking an underwater object. Always disconnect the battery and lock the propeller shaft before working on the V-Drive.

DIRECTLY-MOUNTED MODELS: Align engine and V-Drive as a unit to the propeller shaft coupling.

INDEPENDENTLY-MOUNTED MODELS: First align V-Drive output flange to propeller shaft coupling and tighten V-Drive securely. Next, align engine to the V-Drive.

PROPELLER SHAFT FLANGE ALIGNMENT FOR INDEPENDENTLY-MOUNTED & DIRECTLY-MOUNTED V-DRIVES

- Install #25 Propeller Shaft Coupling onto propeller shaft and tighten the two clamping bolts. Remove set screw, spot drill prop shaft and tighten the set screw into the prop shaft.
- Install and adjust the V-Drive so that the pilot diameters of the #11A Gear Shaft and the #25 Propeller Shaft Coupling engage freely. For V-Drives with #16 Mounting Brackets, make sure that the nuts on the adjusting screws have been loosened before turning adjusting screws.

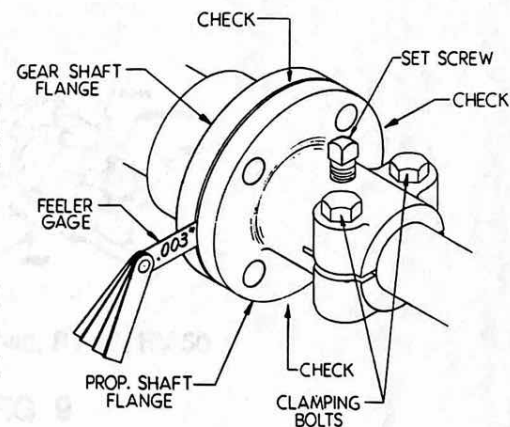

FIG. 6

- Butt the flange faces together.
- Check with a feeler gage in at least 4 places (without rotating either flange) to make sure that there is NO MORE THAN A .003" SPACE between the flanges. (SEE FIG. 6)
- REALIGN V-DRIVE WITH THE PROPELLER SHAFT IF THE SPACE IS MORE THAN .003".
- Without rotating the #11A Gear Shaft, turn the propeller shaft 1/4 turn and check the space between the flanges. If the gap changes, the propeller shaft or the #25 Propeller Shaft Coupling flange face is bent and must be straightened.
- Repeat the above step rotating the propeller shaft in 1/4 turn increments.
- For V-Drives equipped with #16 Mounting Brackets, tighten the nuts on these mounting brackets and the locking nuts on the adjusting screws. Then, remove the set screws from the mounting brackets, spot drill, and securely tighten the set screws.
- Recheck flange alignment and secure flanges together with heat-treated coupling bolts and special high-collared lockwashers supplied. The RV-26 and RV-36 use stainless steel hex head cap screws, nuts, and high collared lockwashers.

ENGINE ALIGNMENT FOR INDEPENDENTLY-MOUNTED MODELS ONLY

NOTE: THE ENGINE MUST BE ADJUSTED SO THAT IT IS ALIGNED TO THE V-DRIVE AFTER THE V-DRIVE OUTPUT FLANGE IS ALIGNED WITH THE PROPELLER SHAFT COUPLING

SHORT INSTALLATIONS WITH FLEXIBLE JOINT ASSEMBLY

Using an accurate steel rule, check faces of the #39 Flexible Joint to make sure that they are parallel within 1/8". Measure this around the diameter in at least 4 places without rotating the assembly. (SEE FIG. 7)

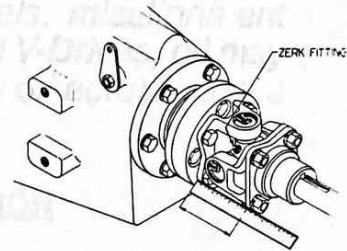
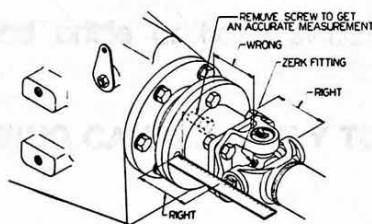

FIG. 7

LONG INSTALLATIONS WITH ADJUSTABLE TUBULAR SHAFT

Measure the distance from the #33A Spool Adapter to the bores in the universal joint which is welded to the tubular shaft. Rotate the shaft exactly 1/4 turn and measure again. All four measured distances must be equal within 1/8". (SEE FIG. 8 & 9)



RV-26 & RV-36

FIG. 8

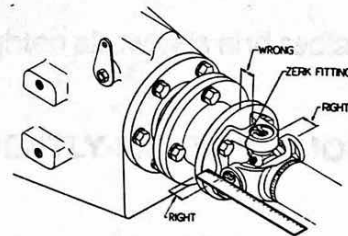

RV-10, RV-40, RV-48, RV-50

FIG. 9

- Slide the #31A Alignment Gage completely around the machined diameter of the #24 Angle Cover so that the tip of the #31A is touching the #27 Splined Connecting Shaft. If there is a gap between the tip of the #31A Alignment Gage and the #27 Splined Connecting Shaft, this indicates that the engine must be moved accordingly to eliminate this gap in order to center the #27 Splined Connecting Shaft in the #24A Oil Seal. (SEE FIG. 10)

- Move the engine until there is no gap between the #31A Alignment Gage and the #27 Splined Connecting Shaft as the #31A Alignment Gage is rotated completely around the #27 Splined Connecting Shaft.

- Repeat the instructions above entitled Short Installations with Flexible Joint Assembly or Long Installations with Adjustable Tubular Shaft.

- BOTH ALIGNMENTS MUST BE CHECKED THOROUGHLY. It is possible for the #27 Splined Connecting Shaft to be perfectly centered and the #39 Flexible Joint to be out of alignment more than 3 degrees or 1/8" as described above.

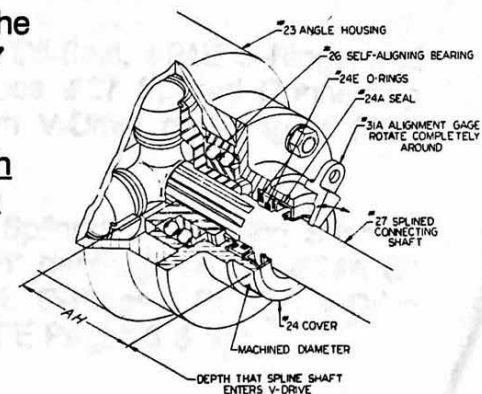

FIG. 10

TROUBLESHOOTING GUIDE

-- OIL LEAKS --

Most oil leaks are due to misalignment between the V-Drive output flange and the propeller shaft coupling and, on Independently-Mounted models, misalignment between the engine and the V-Drive. On Independently-Mounted V-Drives, oil may appear to leak out of the #8 Gear Shaft Oil Seal when in fact the oil actually leaks out the #24A Oil Seal and drips down to the lower seal area.

POSSIBLE CAUSES

Misalignment between #25 Propeller Shaft Coupling and #11A Gear Shaft (output flange) on V-Drive.

V-Drive badly rusted and seals or gaskets leaking:

Hoses stiff and brittle or hose swivels are loose.

SOLUTION

Replace #8 Oil Seal and realign V-Drive with propeller shaft coupling.

Replace #13 Complete Gasket Set and all seals. Realign V-Drive (SEE Pages 5 and 6).

Tighten all swivels and replace #44 hose set.

THE FOLLOWING CAUSES APPLY TO INDEPENDENTLY-MOUNTED MODELS ONLY:

Misalignment between engine and Independently-Mounted V-Drive. This causes the #27 Splined Connecting Shaft to run non-concentric with the #24A Oil Seal. When the shaft does not run in the center of the oil seal, the seal will develop premature wear and leak.

If misalignment is severe enough, the #24C O-Ring Retainer can come into contact with the #27 Splined Connecting Shaft and cause a groove or burr to develop on the shaft.

Badly rusted #27 Splined Connecting Shaft or burr on spline can cut #24A Oil Seal and #24E O-Rings during installation.

During installation, #27 Splined Connecting Shaft not installed into V-Drive far enough. This can cause the spline to ride on the #24A Oil Seal and #24E O-Rings, damaging them.

Replace #24A Oil Seal, #24E O-Rings, and realign engine with V-Drive (SEE Page 6).

In addition to the prior solution, also replace #24C O-Ring Retainer and polish or replace the #27 Splined Connecting Shaft. Realign V-Drive and engine (SEE Pages 5 & 6).

Replace #24A Oil Seal, #24E O-Rings, and polish or replace #27 Splined Connecting Shaft. Realign V-Drive and engine (SEE Pages 5 & 6).

Reinstall #27 Splined Connecting Shaft to the proper "AH" depth. Replace #24A Oil Seal and #24E O-Rings. Realign V-Drive and engine (SEE Pages 5 & 6).

-- WATER IN OIL --

If the oil in the V-Drive appears milky-white, tan, or brown, there is a good chance that water has mixed with the oil. If the oil hadn't previously been checked for quite some time, the gears, bearings, and other internal components may have become rusty and should not be run before being inspected.

POSSIBLE CAUSES

Heavy rust in watercooled cavity of #01C Main Housing can allow water to get into the oil by way of pin-hole leaks.

#6E Oil Cooling Coil is badly corroded or has been damaged during repair.

O-Rings in #6F Coil Terminals are brittle or have been cut during disassembly or repair.

SOLUTION

Apply very light coat of "Marine-Tex" or similar epoxy in porosity area of top watercooled cavity of #01C Main Housing.

Replace #6E Oil Cooling Coil and #6F Coil Terminals and o-rings.

Replace #6F Coil Terminals and o-rings.

-- EXCESSIVE NOISE IN V-DRIVE --

A clatter or rattle in the V-Drive at low RPM is due to drive-line related vibrations, such as the overriding of the propeller during the compression stroke of the engine. This noise may be reduced by tuning up the engine and increasing the idle speed for smoother operation.

POSSIBLE CAUSES

Misalignment of V-Drive with propeller shaft coupling.

Bearing has failed. Rotate V-Drive shaft by hand; it should feel free and easy. Usually, if one bearing has failed, the broken metal particles have also damaged all the other bearings.

Gear tooth has burr from previous bearing failure or from foreign contaminant in oil.

SOLUTION

Realign V-Drive with #25 Propeller Shaft Coupling (SEE Page 5).

Take out #22 Magnetic Plugs and #43S Oil Strainer and check for large metal particles. Replace bearing(s), seals, and gaskets.

In addition to the prior solution, also take off #6B Bottom Cover and visually inspect the gear. Stone out burr or replace gear, seals, and gaskets.

-- LOW OIL PRESSURE --

The following guide applies only to those V-Drives equipped with an oil circulating pump. If there are hoses on the V-Drive on the side opposite the output shaft, then the V-Drive is equipped with an oil circulating pump. Additionally, an oil pressure drop warning light should be present on the instrument panel.

WALTER TROUBLESHOOTING LOW OIL PRESSURE (UNDER 2 PSI)

The #49 Oil Pressure Drop Switch is a 2 PSI normally closed switch; under 2 PSI the warning light on the bridge will light up and above 2 PSI the warning light will go off. The #42A Oil Pump in the V-Drive is driven by the #9AJ Pinion Shaft and #42T Pump Driving Ring so that when the engine is idling at low RPM or the transmission is not in gear, the oil pump develops less than 2 PSI oil pressure and the warning light will be on. Therefore, the warning light should light when the ignition is on and stay lit until the engine RPM increases to approximately 1200 RPM (actual engine RPM may vary as much as 400 RPM) and the transmission is in gear. Extended cruising at low RPM, such as when trolling, is not harmful to the V-Drive, even though the warning light may stay lit, because the V-Drive is also splash-lubricated through the action of the #10 Gear moving through the oil sump.

- Check the oil level. Loss of oil and/or insufficient oil level are the major causes of low oil pressure.
- Check all hoses and swivels for punctures and oil leaks. Even if there is no oil in the bilge, the hoses and swivels on the suction side of the oil pump could be sucking air instead of oil and therefore there would be no oil pressure but no apparent oil leakage.
- Check the operation of the #49 Oil Pressure Drop Switch by switching the port and the starboard #49 Oil Pressure Drop Switches.
- Check the wiring from the #49 Oil Pressure Drop Switch to the bridge by switching the wiring on the port and starboard V-Drives.
- Drain the oil in the V-Drive, clean the #22 Magnetic Plugs, and clean the #43S Oil Strainer.
- Replace the oil with either SAE 30 Heavy Duty Motor Oil, Exxon Spartan EP-68 Gear Oil, or APG-80 Gear Oil. These have approximately the same viscosity. DO NOT USE SAE 80 MOTOR OIL; this is much too heavy an oil.
- Make sure that the dowel pin on the #42B Oil Pump End Cap protrudes the proper amount from the face. See the PUMP ASSEMBLY INSTRUCTION sheet.
- Check that the face of the #42B Oil Pump End Cap is not scored, rusty, or worn. This face must be smooth and free of burrs.
- Check that the welded pin or bent tab of the outer body of the #42A Oil Pump is intact. When installing the #42A Oil Pump, make sure that this welded pin or bent tab goes into the milled slot on the #42T Pump Driving Ring.
- Clean out the #42A Oil Pump and make sure that the inner body of the pump rotates freely within the outer body of the pump. There should be very little resistance or friction within the pump.

WALTER V-DRIVE DISASSEMBLY & REASSEMBLY

NOTE: The following instructions apply specifically to current designs of Independently-Mounted Models without an "IDLER GEAR". Directly-Mounted Models use #23D, #24A-D, and #26D instead of #23, #24A, and #26 respectively. In addition, there is no #24C or #24E on Directly-Mounted Models. Disassembly and reassembly steps of older designs may not be identical, but are very similar. When ordering parts or requesting information it is important to provide the following information found on the brass serial plate located on the side of the #01C main housing opposite the engine (SEE FIG. 11, Page 15):

1. SERIAL NUMBER
2. MODEL NUMBER
3. REDUCTION RATIO

CAUTION: When replacing a gear, shaft, or bearing due to a metal component failure, all bearings should be replaced due to the probable damage to the other bearings from the metallic chips in the oil. Many bearings used in WALTER V-Drives are ordered by W.M.C. with special tolerances for better fits on the shafts and main housing bores. Factory replacement bearings should be ordered from W.M.C. to ensure correct radii on inner and outer races and correct tolerances. **STANDARD "EQUIVALENT" BEARINGS FROM BEARING SUPPLY STORES MAY NOT BE SUITABLE FOR OPERATION IN WALTER V-DRIVES AND MAY FAIL PREMATURELY, CAUSING OTHER INTERNAL DAMAGE.**

GENERAL DISASSEMBLY

- Remove all hoses with swivels from fittings

GEAR SHAFT DISASSEMBLY (Output Shaft)

- Remove #5 Back Cover from #01C Main Housing
- Remove #11AN Locknut and #11AW Lockwasher from #11A Gear Shaft
- Remove #6B Bottom Cover
- Support #10 Gear in #01C Main Housing with 2 parallels, reattach #6B Bottom Cover, and press out #11A Gear Shaft through #15 Bearing, #10 Gear, and #15A Bearing using an arbor press
- Remove #6B Bottom Cover
- Remove loose #10 Gear from #01C Main Housing, and cones of #15 and #15A Bearings
- Remove #4 Front Cover from #01C Main Housing
- Press out cups of #15 and #15A Bearings
- Press out #8 Seal from #4 Front Cover

PINION SHAFT DISASSEMBLY (Input Shaft)

- Remove #24 Angle Housing Cover from #23 Angle Housing
- Press out #24A Seal from #24 Angle Housing Cover
- Remove #24C O-Ring Retainer from #24 Angle Housing Cover
- Remove #24E O-Rings from #24C O-Ring Retainer
- Press off #23 Angle Housing with #26 Self-Aligning Bearing from #01C Main Housing
- Remove #42B Pump End Cap from #03SP Pump Cover
- Take out loose #42A Oil Pump and Spring from inside of #03SP Pump Cover
- Remove #03SP Pump Cover from #01C Main Housing
- Remove pin which holds #42T Pump Driving Ring onto #9AJ Pinion Shaft & Yoke, and slip off #42T from #9AJ
- Remove #9AN Locknut and #9AW Lockwasher from #9AJ Pinion Shaft & Yoke
- Support #9B Gear in #01C Main Housing, and press out #9AJ Pinion Shaft and Yoke (with #34J Universal Joint attached) through #14A Bearing, #9B Gear, and #14 Bearing
- Press #26 Self-Aligning Bearing off front yoke of #34J U-Joint
- Remove #2 Adapter from #01C Main Housing

- Press out cups of #14 and #14A Bearings
- Press #9CT Pinion Shaft Sleeve out of #14A Bearing
- Disassemble crosses and needle bearings from #34J U-Joint to check for wear

DISASSEMBLY OF V-DRIVES WITH IDLER GEAR

1. Disassemble GEAR SHAFT ASSEMBLY
2. Disassemble PINION SHAFT ASSEMBLY
3. Disassemble IDLER SHAFT ASSEMBLY

GENERAL REASSEMBLY

NOTE: During reassembly, use all new seals, gaskets, and o-rings. Do not use any "Form-a-Gasket" type gasket materials. Before reassembly, remove #6D-C Flat Top Cover, #6F Coil Terminals, and #6E Cooling Coil and thoroughly clean top watercooled cavity of #01C Main Housing. Place new o-rings inside #6F Coil Terminals, and reassemble #6E, #6F, and #6D-C to #01C Main Housing. For V-Drives with "IDLER GEAR", assemble Idler Shaft first, and then proceed with general reassembly instructions.

PINION SHAFT ASSEMBLY (Input Shaft)

- Press cup of #14A Bearing into top bore of #01C Main Housing
- Place #13-03SP-G Pump Cover Gasket onto #01C Main Housing and attach #03SP Pump Cover onto #01C Main Housing temporarily with 2 nuts
- Press #9CT Pinion Shaft Sleeve into cone of #14A Bearing
- Turn #01C Main Housing over and place cone of #14A Bearing into cup. Place a bushing over cone of #14A Bearing, and press entire #14A Bearing until the cup hits the pilot step on the #03SP Pump Cover
- Place the #9B Gear into the #01C Main Housing so it sits directly on top of the cone of the #14A Bearing (with #9CT Pinion Shaft Sleeve attached)
- Place cone of the #14 Bearing directly on top of #9B Gear and place cup of the #14 Bearing into the top bore of #01C Main Housing
- Press cup of the #14 Bearing until the cone of the #14 Bearing rests against the #9B Gear
- Place #13-2G Adapter Gasket onto #01C Main Housing and place #2 Adapter onto #01C Main Housing (NOTE: RV-26 and RV-36 have no #2 Adapter. Instead, there is a #9F Spacer Ring which the cup of the #14 Bearing rests against.)
- Press #26 Self-Aligning Bearing onto front end yoke of #34J U-Joint
- Attach #9AJ Pinion Shaft and Yoke to #34J U-Joint, and make sure snap rings are seated properly in the snap ring grooves
- Press entire #9AJ Pinion Shaft and Yoke assembled onto #34J U-Joint and #26 Self-Aligning Bearing into #14 Bearing, #9B Gear, and #14A Bearing. Secure the #9AN Locknut and #9AW Lockwasher onto the #9AJ Pinion Shaft and bend tab of #9AW L'Nut over #9AN Lnut
- Place #27 Splined Connecting Shaft into splined yoke of #34J U-Joint to keep U-Joint centralized, and press #23 Angle Housing onto #26 Self-Aligning Bearing and secure to #2 Adapter with nuts and lockwashers
- Place small amount of light grease into grooves of #24C O-Ring Retainer and into bottom of #24 Angle Housing Cover. Place #24E O-Rings into #24C O-Ring Retainer and place #24C O-Ring Retainer into #24 Angle Housing Cover
- Place #24F Wavy Washer into #24 Angle Housing Cover and against #24C O-Ring Retainer
- Press new #24A Seal into #24 Angle Housing Cover and against #24F Wavy Washer. The #24A Seal should be pressed in far enough so that there is tension on the #24C O-Ring Retainer, but the #24E should be able to be moved around by hand so that it can float with the #27 Splined Connecting Shaft. Place #13-24G Angle Housing Cover Gasket onto #23 Angle Housing, and secure #24 Angle Housing Cover to #23 Angle Housing with nuts and lockwashers.

GEAR SHAFT ASSEMBLY (Output Shaft)

- Press cup of #15 Bearing into the bottom bore of #01C Main Housing
- Place #13-5G Back Cover Gasket onto #01C Main Housing and attach #5 Cover to #01C Main Housing with 2 nuts temporarily
- Turn #01C Main Housing over and place cone of #15 Bearing into cup
- Place a bushing over cone of #15 Bearing, and press entire #15 Bearing until the cup hits pilot step on #5 Back Cover
- Place the #10 Gear into the #01C Main Housing so that it sits directly on top of the cone of the #15 Bearing
- Place the cone of the #15A Bearing on top of the #10 Gear, and press the cup of the #15A Bearing into the bottom bore of the #01C Main Housing until the cone of the #15A Bearing rests against the #10 Gear
- Place the #13-4G Front Cover Gasket onto the #01C Main Housing
- Press new #8 Seal into #4 Front Cover
- Secure the #4 Front Cover to the #01C Main Housing with nuts and lockwashers
- Place the #11A Gear Shaft loosely into #10 Gear to locate spline
- Place #13-6BG Bottom Cover Gasket onto the #01C Main Housing and attach #6B Bottom Cover to the #01C Main Housing with nuts and lockwashers
- Press the #11A Gear shaft into the #10 Gear, #15 Bearing, and #15A Bearing until the shaft bottoms. Be careful not to damage flange face of #11A Gear Shaft
- Secure the #11AN Locknut and #11AW Lockwasher to the #11A Gear Shaft and bend tab from #11AW Lockwasher over #11AN Locknut

FINAL ASSEMBLY INSTRUCTIONS

- Take off #03SP Pump Cover from #01C Main Housing and attach #42T Pump Driving Ring to #9AJ Pinion Shaft and Yoke with pin
- Take off #5 Back Cover from #01C Main Housing
- Using a bushing, press the cup of the #14A Bearing until the entire Pinion Shaft Assembly is pushed against the step of the #2 Adapter. Use a depth micrometer, measure the distance between the face of the #01C Main Housing and the cup of the #14A Bearing (including the #13-03SP-G Pump Cover Gasket), and then the step on the #03SP Pump Cover. There must be .005" clearance or "End-Play" between the step on the #03SP Pump Cover and the cup of the #14A Bearing. If there is more than .005" clearance, add shims as required; if there is less than .005" clearance, add gaskets as required. #9B Pinion Gear must rotate freely.
- Using a bushing, press the cup of the #15 Bearing until the entire Gear Shaft Assembly is pushed against the #4 Front Cover. Use a depth micrometer, measure the distance between the face of the #01C Main Housing and the cup of the #15 Bearing (including the #13-5G Back Cover Gasket), and then the step on the #5 Back Cover. There must be .005" clearance or "End-Play" between the step on the #5 Back Cover and the cup of the #15 Bearing. If there is more than .005" clearance, add shims as required; if there is less than .005" clearance, add gaskets as required. #10 Gear must rotate freely.
- Secure the #03SP Pump Cover and the #5 Back Cover to the #01C Main Housing with nuts and lockwashers
- Follow Pump Assembly Instructions on PAGE 13

PUMP ASSEMBLY INSTRUCTIONS FOR RV-20, RV-26, RV-30, RV-36, RV-40, RV-48, & RV-50 V-DRIVES

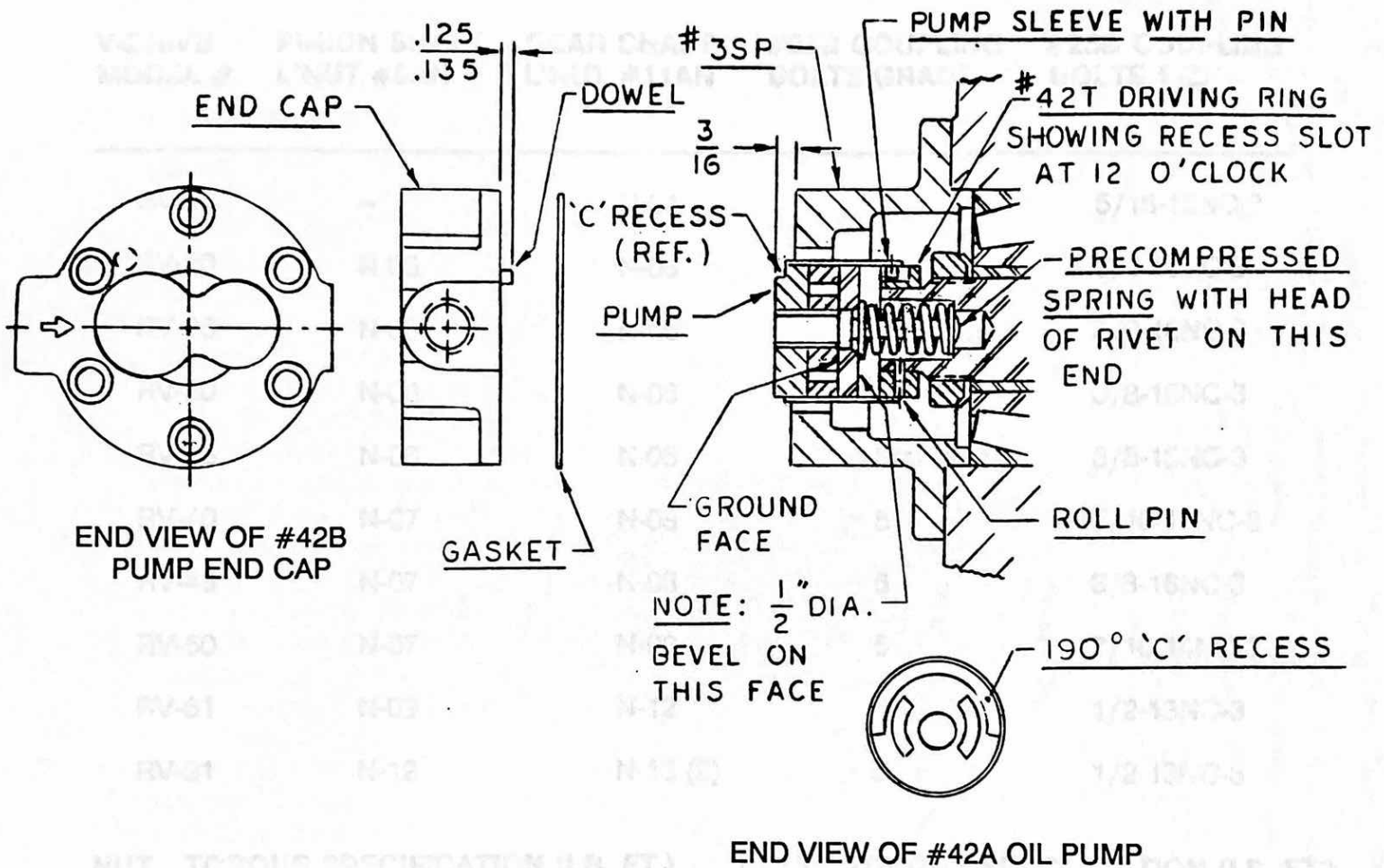

NOTE: $\frac{1}{2}$ " DIA.
BEVEL ON
THIS FACE

190° 'C' RECESS

END VIEW OF #42A OIL PUMP

- Check that #42T Pump Driving Ring is attached onto the end of the #9AJ Pinion Shaft with roll pin (end of roll pin should be even with inside bore of #9AJ) and make sure there are no burrs on the outside diameter of the #42T.
- Rotate #42T Pump Driving Ring until milled slot is at 12 o'clock.
- Place precompressed spring (rounded head of rivet first) into hole in #9AJ Pinion Shaft.
- Position outer body of #42A Oil Pump so that the welded pin or bent tab is at 12 o'clock. Place #42A Oil Pump onto #42T Pump Driving Ring so that the welded pin or bent tab of outer housing on #42A Oil Pump fits into milled slot of #42T Pump Driving Ring. It may be helpful to scribe a line on the outer housing of the #42A Oil Pump directly in line with the welded pin or bent tab.
- Check to make sure that the #42A Oil Pump projects from the #3SP Pump Cover approximately 3/16". Push on the #42A Oil Pump to make sure that the welded pin or bent tab is properly positioned in the recess slot.
- Without turning the outer housing of the #42A Oil Pump, rotate the inner body of the #42A Oil Pump so that the 190 degree 'C' recess is centered at 12 o'clock. (See END VIEW OF #42A OIL PUMP).
- Place the #13-3G Pump Gasket onto the face of the #3SP Pump Cover. The #42B Oil Pump End Cap is positioned with the dowel pin at 10 o'clock. With the inner body of the #42A Oil Pump positioned correctly, the dowel pin on the #42B Oil Pump End Cap will fit into the 190 degree 'C' recess of the #42A Oil Pump.
- Tighten 2 cap screws at 12 o'clock and 6 o'clock only to position #42B Oil Pump End Cap within 3/16" of #3SP Pump Cover. Then, push in on #42B Oil Pump End Cap to ensure that the welded pin or bent tab of #42A Oil Pump is still aligned to the #42T Pump Driving Ring milled slot. If spring tension cannot be felt, the #42A Oil Pump is not positioned properly. Tighten 2 screws fully. Add 4 screws to complete assembly.

NOTE: Suction line shown on left side. If suction assembled from right side, reverse assembly procedure 180 degrees.

TORQUE SPECIFICATIONS FOR WALTER V-DRIVES

V-DRIVE MODEL #	PINION SHAFT L'NUT #9AN	GEAR SHAFT L'NUT #11AN	#25B COUPLING BOLTS GRADE	#25B COUPLING BOLTS SIZE
-----------------	-------------------------	------------------------	---------------------------	--------------------------

RV-10	--	N-04	7	5/16-18NC-3
RV-20	N-05	N-06	5	3/8-16NC-3
RV-26	N-05	N-06	Stainless	3/8-16NC-3
RV-30	N-06	N-06	5	3/8-16NC-3
RV-36	N-06	N-06	Stainless	3/8-16NC-3
RV-40	N-07	N-08	5	7/16-14NC-3
RV-48	N-07	N-08	5	3/8-16NC-3
RV-50	N-07	N-08	5	7/16-14NC-3
RV-61	N-09	N-12	5	1/2-13NC-3
RV-91	N-12	N-15 (2)	5	1/2-13NC-3

NUT TORQUE SPECIFICATION (LB. FT.)

BOLT TORQUE SPECIFICATION (LB. FT.)

N-04	150-190	5/16-18NC-3	20-25
N-05	160-200	3/8-16NC-3	27-37
N-06	170-210	7/16-14NC-3	45-55
N-07	180-220	1/2-13NC-3	65-80
N-08	190-230		
N-09	200-240		
N-12	225-265		
N-15	250-290		

V-DRIVE ALIGNMENT

V-DRIVE MAINTENANCE

OIL CHANGE & FLEX JOINT LUBRICATION

After the first 100 hours of operation and every season and/or 500 hours thereafter, the oil should be changed. See PAGE 4 for recommended oil types and capacities. Additionally, on Independently-Mounted V-Drives only, the FLEX-JOINT must be re-lubricated (SEE PAGE 4). NOTE: Disregard reference to oil lines and oil strainers if the V-Drive is not equipped with an oil circulating pump.

- Run engine and V-Drive to warm up oil inside the V-Drive. Shut engine off and disconnect battery. Remove the drain plug that is opposite the #43S Oil Strainer on #6B Bottom Cover and drain oil. Reinstall drain plug (SEE FIG. 11).
- Disconnect the #44-2 Oil Hose attached to the #43S Oil Strainer (leave elbow on strainer), unscrew the #43S Oil Strainer from the #6B Bottom Cover, and clean outside surface of the #43S Oil Strainer. NOTE: Older models may have a #43F Oil Screen instead of a #43S Oil Strainer. #6B Bottom Cover must be removed to clean #43F Oil Screen.

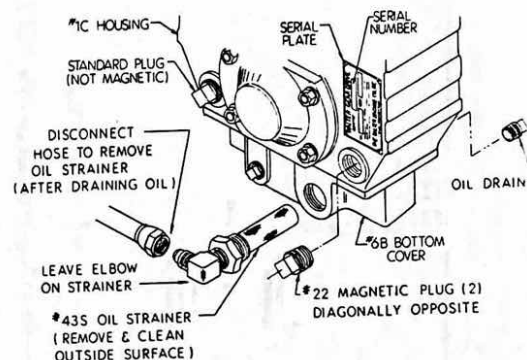

FIG. 11

- Reinstall the #43S Oil Strainer and reconnect #44-2 Oil Hose.
- Unscrew the two #22 Magnetic Plugs that are located on diagonally opposite lower corners of the #01C Main Housing (Only 1 on RV-10D). Clean #22 Magnetic Plugs and check to make sure they are magnetic. Reinstall #22 Magnetic Plugs.
- Refill with proper oil type and capacity found on PAGE 4.

WATER DRAIN

For protection against freezing during winter lay-up, the waterjacket in the top of the #01C Main Housing must be drained.

- Remove the small pipe plugs marked "Water Drain" located diagonally opposite one another on the front and back of the #01C Main Housing near the top. (SEE FIG. 4 & 5)
On the RV-10 only, one of the water lines going into the #6 water-cooled cover must be disconnected to drain the water.

V-DRIVE REALIGNMENT

Realignment is necessary whenever the boat is launched after being hauled from the water or after striking an underwater object. Always disconnect the battery and lock the propeller shaft before working on the V-Drive. Engines with rubber or adjustable mounts may sag and must be raised with adjustments or shims for proper alignment (SEE PAGES 5 - 6).

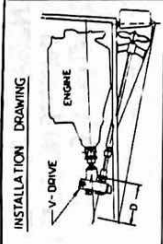

ANGLE	D	I	O	Q
10°	27 1/16	6 1/16	15 1/16	7 1/4
12°	22 3/32	6 1/4	15 3/32	7 1/32
15°	17 3/32	6 1/8	15 3/32	7 3/32

GENERAL ASSEMBLY PRINT - DIMENSIONS REFER ONLY TO RV-40 INDEPENDENT-MOUNT

- NOTES:**
- I - ALIGNMENT GAGE FOR POSITIONING & CHECKING ALIGNMENT BETWEEN ENGINE & V-DRIVE ANGLE STANDARD - CAN BE SUPPLIED WITH SPECIAL 10° OR 15° ANGLE
 - III - COY SHAFT LENGTH TO SUIT
 - IV - INCREASE DIMENSION BY 1/8 WITH 3:12-1 RATIO

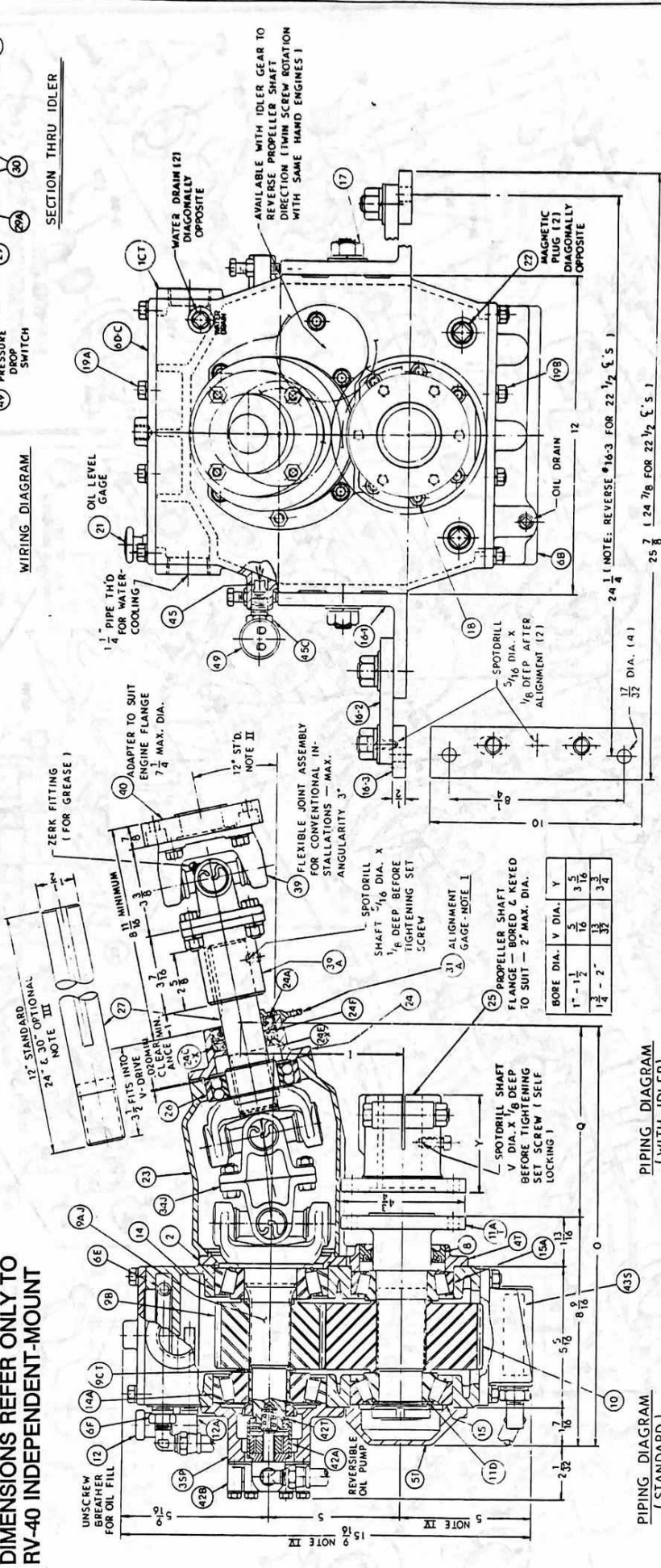

PIPING DIAGRAM (WITH IDLER)

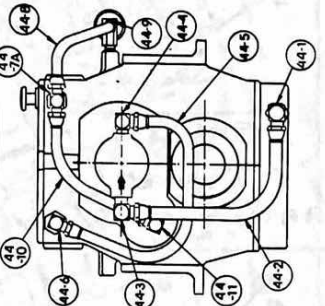

PIPING DIAGRAM (STANDARD)

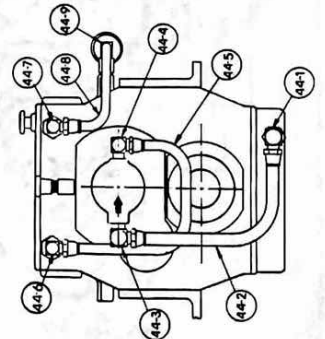

NOTE - MOUNTING BRACKETS HAVE 3-WAY ADJUSTMENT - 3/16 IN EVERY DIRECTION

- REV 10-28-85
- REV 9-14-84
- REV 4-10-84
- REV 7-16-83
- REV 7-20-83
- REV 12-12-75
- REV 9-3-74
- REV 11-2-72
- REV 2-1-71
- REV 12-1-70

**GENERAL ASSEMBLY PRINT -
DIMENSIONS REFER ONLY TO
RV-40D DIRECT-MOUNT**

SECTION IHRU IDLER

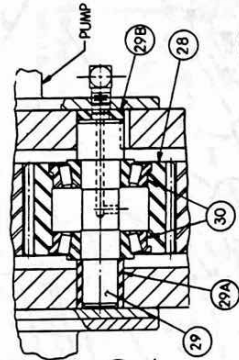

AVAILABLE WITH IDLER GEAR
TO REVERSE ROTATION OF
DRIVEN SHAFT WITH
STANDARD RATIOS

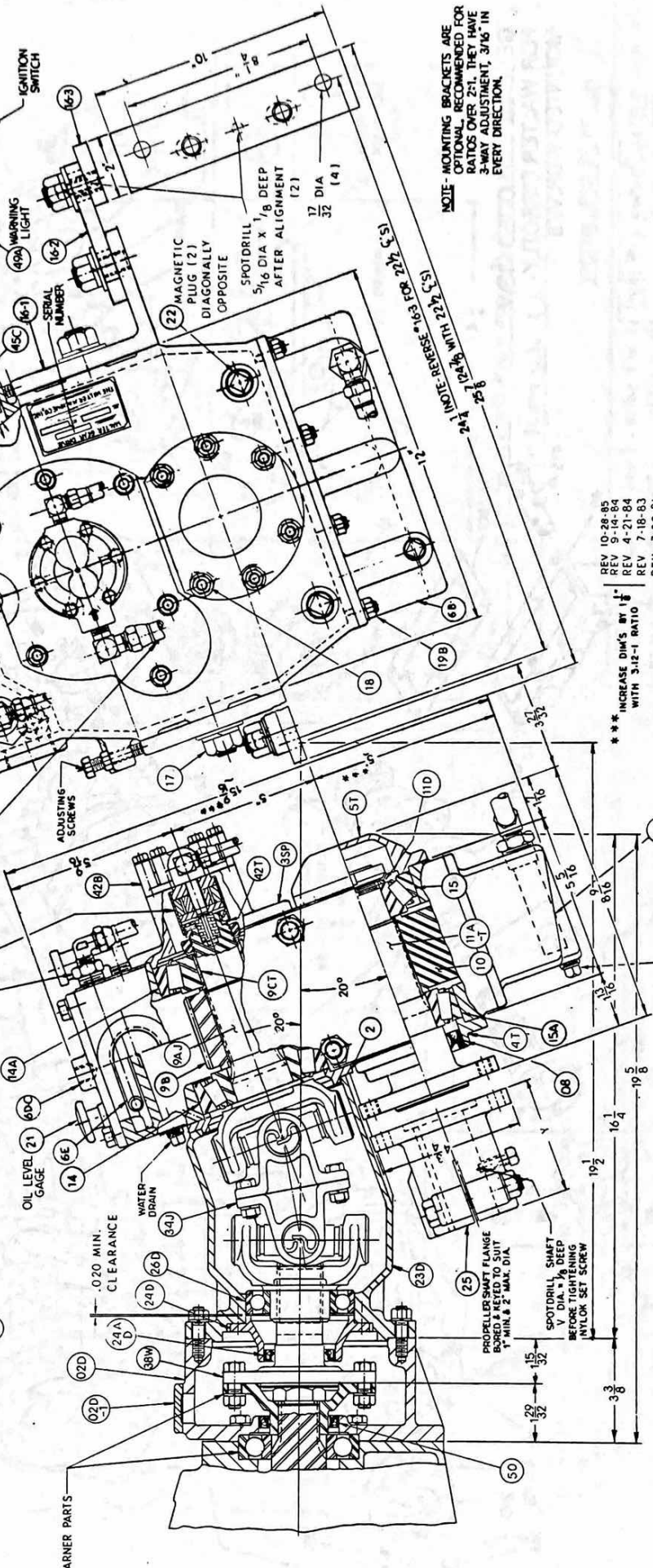
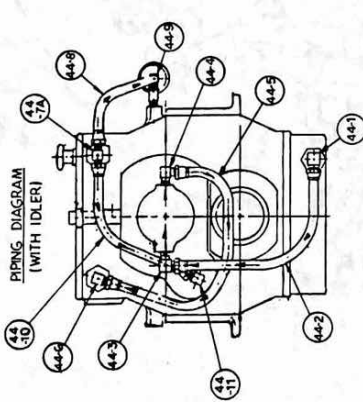
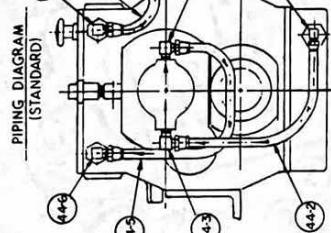

**NOTE - MOUNTING BRACKETS ARE
OPTIONAL RECOMMENDED FOR
RATIOS OVER 2:1. THEY HAVE
3-WAY ADJUSTMENT, 3/16 IN
EVERY DIRECTION.**

REV 10-28-85
REV 9-14-84
REV 4-21-84
REV 7-18-83
REV 7-20-81
REV 10-6-70
REV 7-23-70

*** INCREASE DIM'S BY 1/16
WITH 3:12-1 RATIO

RV-10
PEARSON
(SPECIAL)

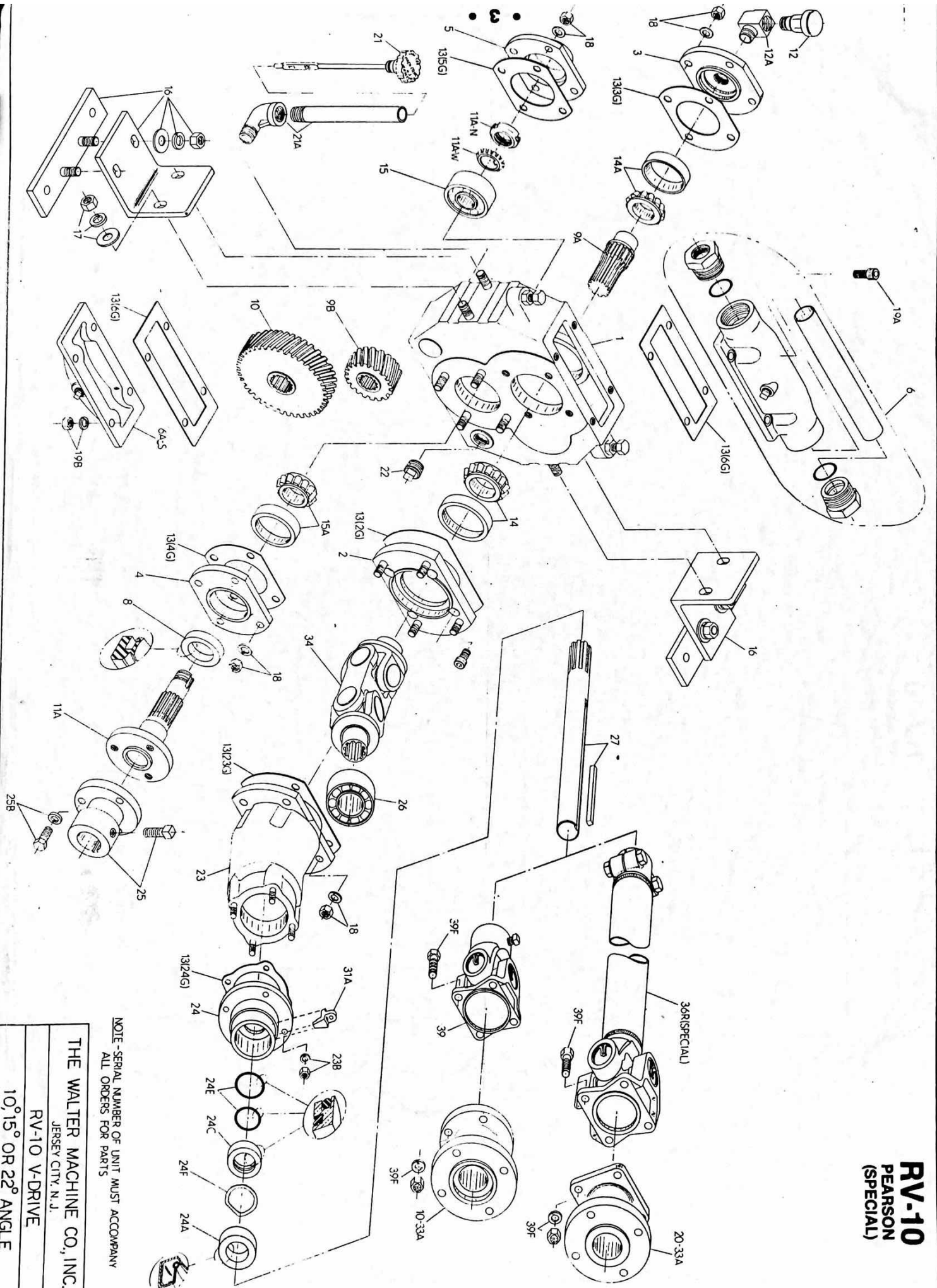

NOTE - SERIAL NUMBER OF UNIT MUST ACCOMPANY
 ALL ORDERS FOR PARTS

THE WALTER MACHINE CO., INC.
 JERSEY CITY, N. J.
 RV-10 V-DRIVE
 10°, 15° OR 22° ANGLE