

WSM

WORKSHOP MANUAL DIESEL ENGINES

**D1102-B, D1302-B, D1402-B,
V1502-B, V1702-B, V1902-B**

Kubota

INTRODUCTION

- This Workshop Manual provides general description, and comprehensive information for servicing Kubota 01102-8, 01302-8, 01402-B, V1502-B, V1702-B, V1902-B diesel engines. It consists of five sections as following:
- Section I "Specifications and Performance Curves" covers specifications and performance curves.
- Section II "General Description" covers newest information on the features, functions and constructions of these Kubota engines.
- Section III and IV "Engine" and "Electrical System" cover disassembling and assembling procedures, checking and servicing instructions. In addition, a troubleshooting chart with reference pages given is provided at the beginning of each section, it helps you find out the cause of malfunction easily.
- Section V "Service Directions" covers all reference values and allowable limits required for servicing.

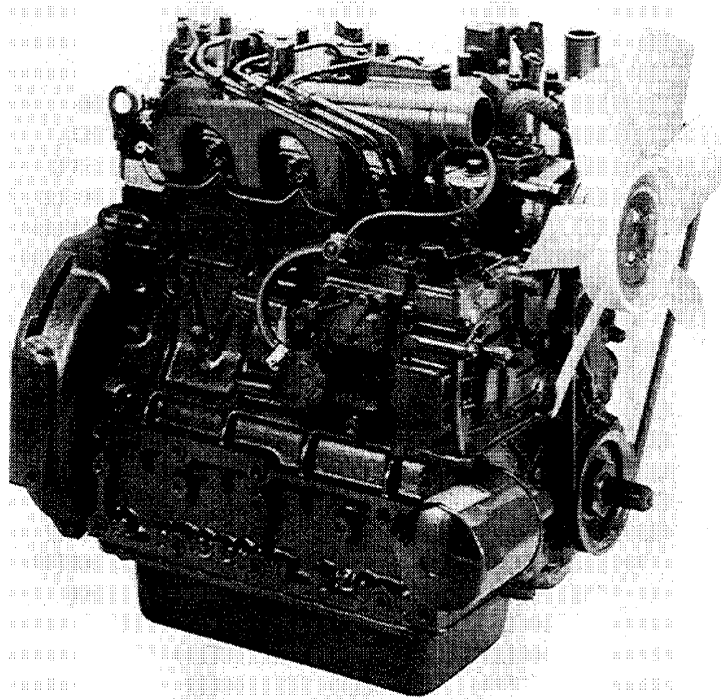

0078P001

- * KUBOTA Corporation reserves the right to change the specifications without notice.
- * No part of this manual may be reproduced without permission of KUBOTA Corporation.

CONTENTS

Section I	SPECIFICATIONS AND PERFORMANCE CURVES	3
Section II	GENERAL DESCRIPTION	13
	1. Engine	
	2. Lubrication System	
	3. Cooling System	
	4. Fuel System	
	5. Electrical System	
Section III	ENGINE	27
	1. Troubleshooting	
	2. Disassembly and Reassembly	
	3. Servicing	
Section IV	ELECTRICAL SYSTEM.....	71
	1. Troubleshooting	
	2. Alternator and Regulator	
	3. Starter and Glow Plug	
Section V	SERVICE DIRECTIONS.....	97

Section I

SPECIFICATIONS AND PERFORMANCE CURVES

- D1102-B4
- D1302-B5
- D1402-B6
- V1502-B7
- V1702-B8
- V1902-B9
- DIMENSIONS 10

Section ■

SPECIFICATIONS AND PERFORMANCE CURVES

• D1102-B

Specifications

Model		D1102-B
Type		Vertical, water-cooled, 4-cycle diesel engine
Number of Cylinders		3
Bore x Stroke	mm (inch)	Ji76 x 82 L (Ji2.99 x 3.23 L)
Total Displacement		cm ³ (cu.in.) 1115 (68.04)
Brake H.P.	DIN 6270-NA	14.3kW /2800 min ⁻¹ (rpm) (19.4 P.S./ 2800 min ⁻¹ (rpm))
	DIN 6270-NB	16.2kW /2800 min ⁻¹ (rpm) (22.0 P.S./2800 min ⁻¹ (rpm))
	DIN70020	17.7kW /2800 min ⁻¹ (rpm) (24.0 P.S./2800 min ⁻¹ (rpm))
	SAE Gross H.P.	19.0kW /2800 min ⁻¹ (rpm) (25.5 H.P./2800 min ⁻¹ (rpm))
	SAE Intermittent H.P.	16.8kW /2800 min ⁻¹ (rpm) (22.5 H.P./2800 min ⁻¹ (rpm))
	SAE Cont. H.P.	14.5kW /2800 min ⁻¹ (rpm) (19.4 H.P./2800 min ⁻¹ (rpm))

Maximum Bare Speed	3000 min ⁻¹ (rpm)
Minimum Bare Idling Speed	800 min ⁻¹ (rpm)
Combustion Chamber	Spherical Type
Fuel Injection Pump	Bosch K Type mini pump
Governor	Centrifugal Ball Mechanical Governor
Injection Nozzle	DN 12SD 12
Injection Timing	0.436 rad. (25") before T.D.C.
Injection Pressure	13.73 MPa (140 kgf/cm ² , 1991 psi)
Compression Ratio	21
Cooling System	Pressurized radiator (8.83 x 10 ⁴ Pa, 0.9 kgf/cm ² , 12.8 psi) Forced circulation (with water pump)
Starting System	Electric Starting with Cellstarter (12V, 1.0kW)
Dynamo for Charging	12V, 300W
Fuel	Diesel Fuel No.2-D
Weight (Dry)	146kg (321.9 lbs.)
Battery	12 V, 80AH, equivalent
Direction of Rotation	Counter-clockwise from flywheel side
Application	General Power Source

Performance Curves

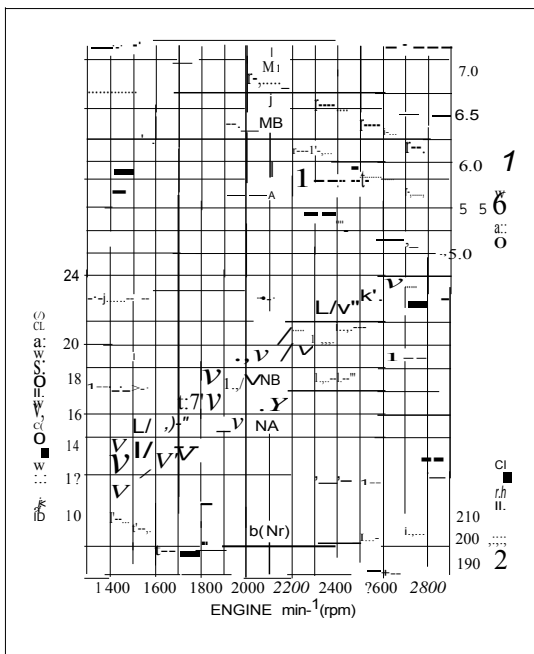

Note:
Each per formance curves, obtained i n accordance with DIN 6270 and DIN 70020, are corrected to 101kPa (760mmHg), and 20° C, 60% humidity.

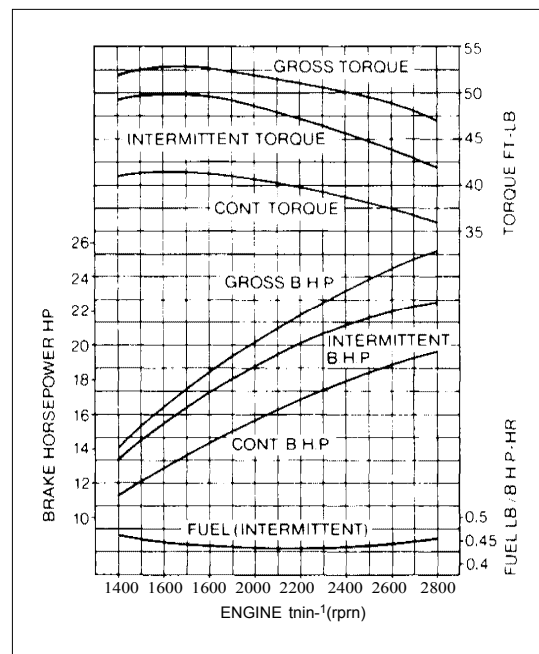

Note:
Each performance curves, obtained in accordance with SAE J816b, are corrected to 101kPa (760mmHg), and 20° C, 60% humidity.

• 01302-B

Specifications

Model		D1302-B
Type		Vertical, water-cooled, 4-cycle diesel engine
Number of Cylinders		3
Bore x Stroke	mm (inch)	φ 82 x 82 L (φ 3.23 x 3.23 L)
Total Displacement		cm ³ (cu.in.) 1299 (79.27)
Brake H.P.	D1N 6270-NA	17.3 kW / 2800 min ⁻¹ (rpm) (23.5 P.S. / 2800 min ⁻¹ (rpm))
	DIN 6270-NB	18.8 kW / 2800 min ⁻¹ (rpm) (25.5 P.S. / 2800 min ⁻¹ (rpm))
	DIN 70020	21.0 kW / 2800 min ⁻¹ (rpm) (28.5 P.S. / 2800 min ⁻¹ (rpm))
	SAE Gross H.P.	22.4 kW / 2800 min ⁻¹ (rpm) (30.0 H.P. / 2800 min ⁻¹ (rpm))
	SAE Intermittent H.P.	20.1 kW / 2800 min ⁻¹ (rpm) (27.0 H.P. / 2800 min ⁻¹ (rpm))
	SAE Cont. H.P.	17.5 kW / 2800 min ⁻¹ (rpm) (23.5 H.P. / 2800 min ⁻¹ (rpm))

Maximum Bare Speed	3000 min ⁻¹ (rpm)
Minimum Bare Idling Speed	800 min ⁻¹ (rpm)
Combustion Chamber	Spherical Type
Fuel Injection Pump	Bosch K Type mini pump
Governor	Centrifugal Ball Mechanical Governor
Injection Nozzle	DN 12SD 12
Injection Timing	0.436 rad. (25°) before T.D.C.
Injection Pressure	13.73 MPa (140 kgf/cm ² , 1991 psi)
Compression Ratio	21
Cooling System	Pressurized radiator (8.83 x 1a4Pa, 0.9 kgf/cm ² , 12.8 psi) Forced circulation (with water pump)
Starting System	Electric Starting with Cell starter (12V, 1.0kW)
Dynamo for Charging	12V, 300W
Fuel	Diesel Fuel No.2-D
Weight (Dry)	147 kg (324.1 lbs.)
Battery	12 V, 80AH, equivalent
Direction of Rotation	Counter-clockwise from flywheel side
Application	General Power Source

Performance Curves

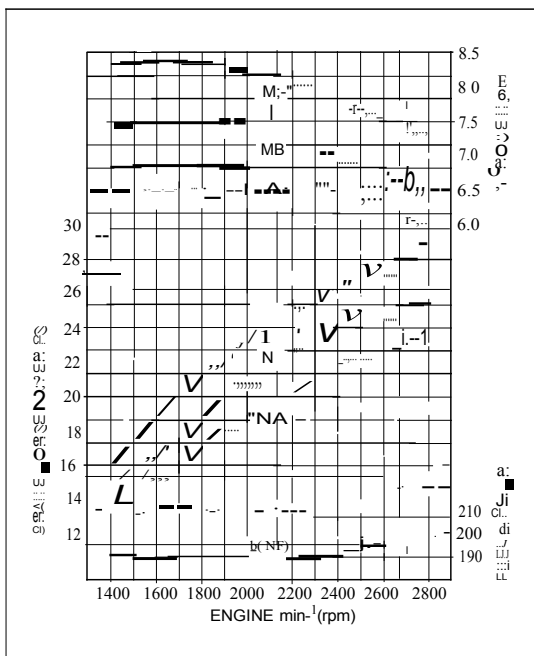

Note:
Each performance curves, obtained in accordance with DIN 6270 and DIN 70020, are corrected to 101kPa (760mmHg) , and 20°C, 60% humidity.

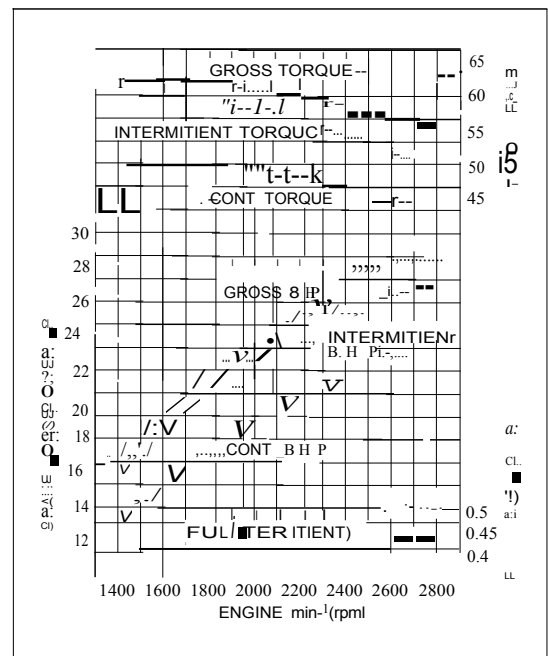

Note:
Each performance curves, obtained in accordance with SAE J816b are corrected to 101kPa (760 mmHg) , and 20° C, 60% humidity.

• 01402-e

Specifications

Model		D1402-B
Type		Vertical, water-cooled, 4-cycle diesel engine
Number of Cylinders		3
Bore x Stroke		mm (inch) $\phi 85 \times 82 \text{ L} (\phi 3.25 \times 3.23 \text{ L})$
Total Displacement		cm ³ (cu.in.) 1395 (85.13)
Brake H.P.	DIN 6270-NA	18.4 kW / 2800 min ⁻¹ (rpm) (25.0 P.S. / 2800 min ⁻¹ (rpm))
	DIN 6270-NB	19.9 kW / 2800 min ⁻¹ (rpm) (27.0 P.S. / 2800 min ⁻¹ (rpm))
	DIN 70020	22.4 kW / 2800 min ⁻¹ (rpm) (30.5 P.S. / 2800 min ⁻¹ (rpm))
	SAE Gross H.P.	23.9 kW / 2800 min ⁻¹ (rpm) (32.0 H.P. / 2800 min ⁻¹ (rpm))
	SAE Intermittent H.P.	21.3 kW / 2800 min ⁻¹ (rpm) (28.5 H.P. / 2800 min ⁻¹ (rpm))
	SAE Cont. H.P.	18.7 kW / 2800 min ⁻¹ (rpm) (25.0 H.P. / 2800 min ⁻¹ (rpm))

Maximum Bare Speed	3000 min ⁻¹ (rpm)
Minimum Bare Idling Speed	800 min ⁻¹ (rpm)
Combustion Chamber	Spherical Type
Fuel Injection Pump	Bosch K Type mini pump
Governor	Centrifugal Ball Mechanical Governor
Injection Nozzle	DN 12SD 12
Injection Timing	0.436 rad. (25°) before T.D.C.
Injection Pressure	13.73 MPa (140 kgf/cm ² , 1991 psi)
Compression Ratio	21
Cooling System	Pressurized radiator (8.83 x 104 Pa, 0.9 kgf/cm ² , 12.8 psi) Forced circulation (with water pump)
Starting System	Electric Starting with Cell starter (12V, 1.4kW)
Dynamo for Charging	12V, 300W
Fuel	Diesel Fuel No.2-D
Weight (Dry)	148.2kg (326.7lbs.)
Battery	12V, 110AH, equivalent
Direction of Rotation	Counter-clockwise from flywheel side
Application	General Power Source

Performance Curves

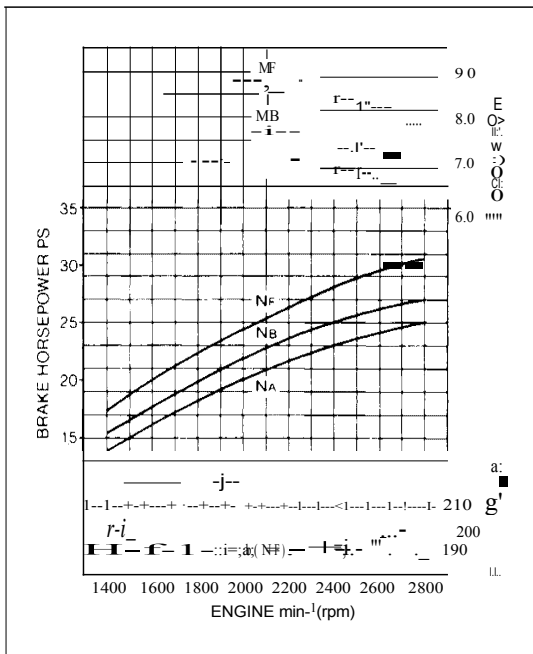

Note:
Each performance curves, obtained in accordance with DIN 6270 and DIN 70020, are corrected to 101kPa (760mmHg), and 20°C, 60% humidity.

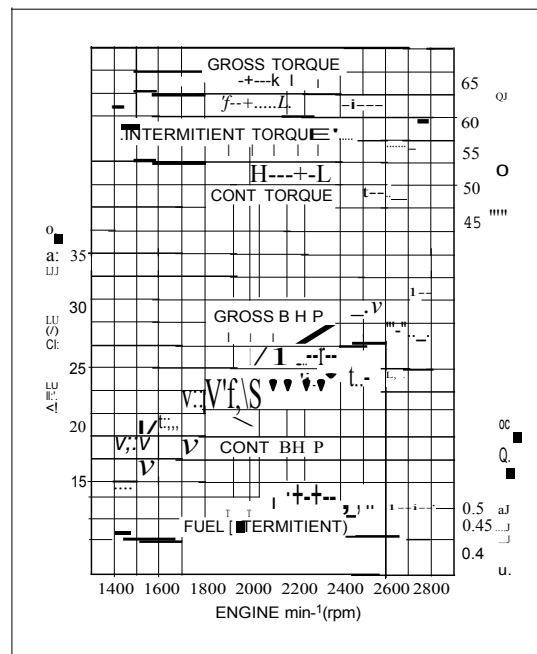

Note:
Each performance curves, obtained in accordance with SAE J816b, are corrected to 101kPa (760 mmHg), and 20°C, 60% humidity.

• v1so2-e

Specifications

Model		V1502 B
Type		Vertical, water-cooled, 4-cycle diesel engine
Number of Cylinders		4
Bore x Stroke mm (inch)		ef. 76 x 82 L (ef. 2.99 x 3.23 L)
Total Displacement cm ³ (cu.in.)		1487 (90.74)
Brake H.P.	DIN 6270-NA	19.1 kW / 2800 min ⁻¹ (rpm) (26.0 P.S. / 2800 min ⁻¹ (rpm))
	DIN 6270-NB	21.3 kW / 2800 min ⁻¹ (rpm) (29.0 P.S. / 2800 min ⁻¹ (rpm))
	DIN 70020	23.5 kW / 2800 min ⁻¹ (rpm) (32.0 P.S. / 2800 min ⁻¹ (rpm))
	SAE Gross H.P.	25.4 kW / 2800 min ⁻¹ (rpm) (34.0 H.P. / 2800 min ⁻¹ (rpm))
	SAE Intermittent H.P.	22.4 kW / 2800 min ⁻¹ (rpm) (30.0 H.P. / 2800 min ⁻¹ (rpm))
	SAE Cont. H.P.	19.4 kW / 2800 min ⁻¹ (rpm) (26.0 H.P. / 2800 min ⁻¹ (rpm))

Maximum Bare Speed	3000 min ⁻¹ (rpm)
Minimum Bare Idling Speed	800 min ⁻¹ (rpm)
Combustion Chamber	Spherical Type
Fuel Injection Pump	Bosch K Type mini pump
Governor	Centrifugal Ball Mechanical Governor
Injection Nozzle	DN 12 SD 12
Injection Timing	0.436 rad. (25°) before T.D.C.
Injection Pressure	13.73 MPa (140 kgf/cm ² , 1991 psi)
Compression Ratio	21
Cooling System	Pressurized radiator (8.83 x 104 Pa, 0.9 kgf/cm ² , 12.8 psi) Forced circulation (with water pump)
Starting System	Electric Starting with Cell starter (12V, 1.4kW)
Dynamo for Charging	12V, 300 W
Fuel	Diesel Fuel No.2-D
Weight (Dry)	175.7 kg (387.3 lbs.)
Battery	12V, 110AH, equivalent
Direction of Rotation	Counter-clockwise from flywheel side
Application	General Power Source

Performance Curves

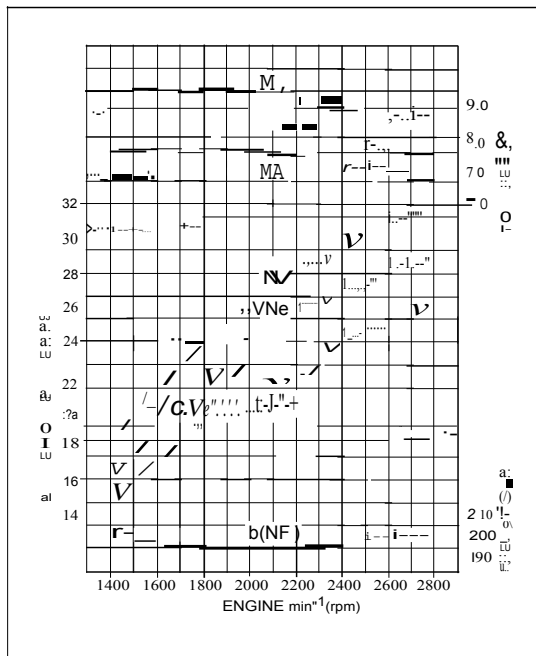

Note:
Each performance curves, obtained in accordance with DIN 6270 and DIN 70020, are corrected to 101kPa (760mmHg) , and 20°C, 60% humidity .

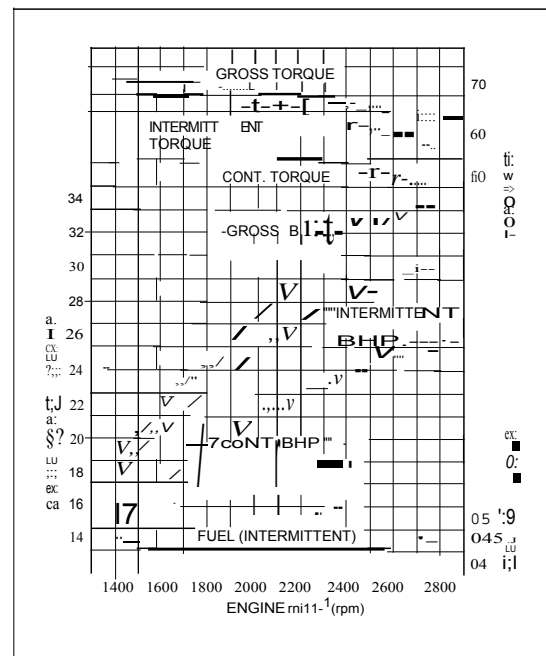

Note:
Each performance curves, obtained in accordance with SAE J816b, are corrected to 101kPa (760mmHg) , and 20° C, 60% humidity.

•V1702-B

Specifications

Model		V1702-B
Type		Vertical, water-cooled, 4-cycle diesel engine
Number of Cylinders		4
Bore x Stroke	mm (inch)	φ82 x 82 L (3.23 x 3.23 L)
Total Displacement		cm ³ (cu.in.) 1732 (105.69)
Brake H.P.	DIN 6270-NA	22.8 kW / 2800 min ⁻¹ (rpm) (31.0 P.S. / 2800 min ⁻¹ (rpm))
	DIN 6270-NB	25.0 kW / 2800 min ⁻¹ (rpm) (34.0 P.S. / 2800 min ⁻¹ (rpm))
	DIN 70020	27.9 kW / 2800 min ⁻¹ (rpm) (38.0 P.S. / 2800 min ⁻¹ (rpm))
	SAE Gross H.P.	29.8 kW / 2800 min ⁻¹ (rpm) (40.0 H.P. / 2800 min ⁻¹ (rpm))
	SAE Intermittent H.P.	26.9 kW / 2800 min ⁻¹ (rpm) (36.0 H.P. / 2800 min ⁻¹ (rpm))
	SAE Cont. H.P.	23.1 kW / 2800 min ⁻¹ (rpm) (31.0 H.P. / 2800 min ⁻¹ (rpm))

Maximum Bare Speed	3000 min ⁻¹ (rpm)
Minimum Bare Idling Speed	800 min ⁻¹ (rpm)
Combustion Chamber	Spherical Type
Fuel Injection Pump	Bosch K Type mini pump
Governor	Centrifugal Ball Mechanical Governor
Injection Nozzle	DN 12SD 12
Injection Timing	0.436 rad. (25°) before T.D.C.
Injection Pressure	13.73 MPa (140 kgf/cm ² , 1991 psi)
Compression Ratio	21
Cooling System	Pressurized radiator (8.83 x 1a4Pa, 0.9 kgf/cm ² , 12.8 psi) Forced circulation (with water pump)
Starting System	Electric Starting with Cell starter (12V, 1.4kW)
Dynamo for Charging	12V, 300W
Fuel	Diesel Fuel No.2-D
Weight (Dry)	177.1 kg (390.4 lbs.)
Battery	12V, 110AH, equivalent
Direction of Rotation	Counter-clockwise from flywheel side
Application	General Power Source

Performance Curves

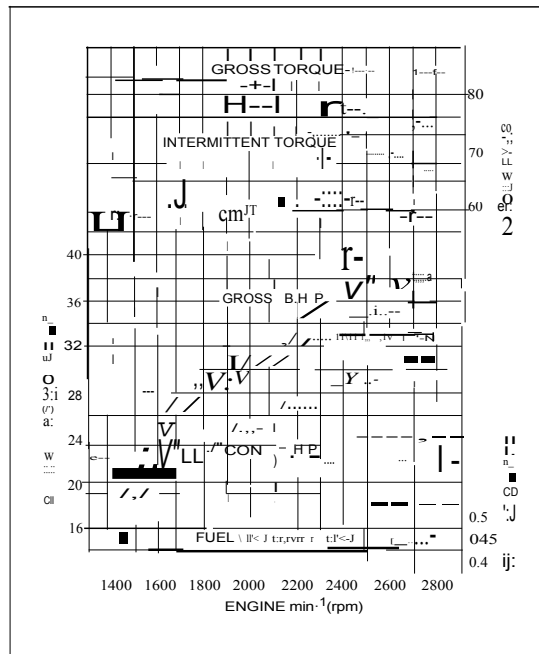
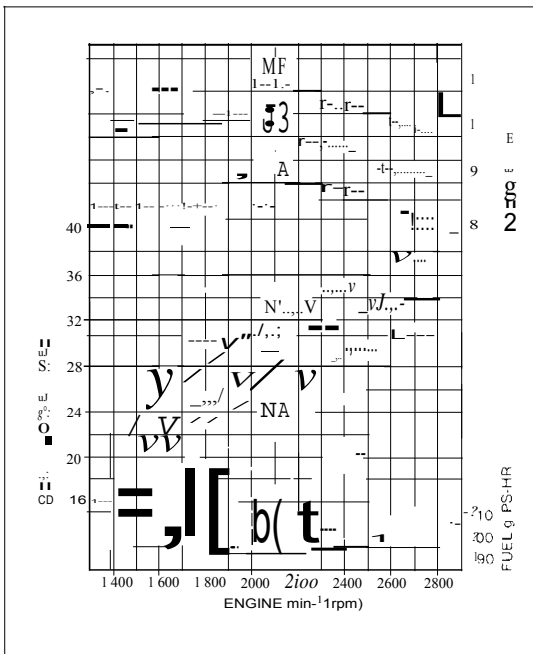

Note:
Each performance curves, obtained in accordance with DIN 6270 and DIN 70020, are corrected to 101kPa (760mmHg), and 20° C, 60% humidity.

Note:
Each performance curves, obtained in accordance with SAE J816b, are corrected to 101kPa (760mmHg), and 20° C, 60% humidity.

v1so2-e

Specifications

Model		V1902-B
Type		Vertical, water-cooled, 4-cycle diesel engine
Number of Cylinders		4
Bore x Stroke mm (inch)		$q: 85 \times 82 \text{ L} (q: 3.35 \times 3.23 \text{ L})$
Total Displacement cm ³ (cu.in.)		1861 (113.57)
Brake H.P.	DIN 6270-NA	24.3 kW / 2800 min ⁻¹ (rpm) (33.0 P.S. / 2800 min ⁻¹ (rpm))
	DIN 6270-NB	26.5 kW / 2800 min ⁻¹ (rpm) (36.0 P.S. / 2800 min ⁻¹ (rpm))
	DIN 70020	30.2 kW / 2800 min ⁻¹ (rpm) (41.0 P.S. / 2800 min ⁻¹ (rpm))
	SAE Gross H.P.	32.1 kW / 2800 min ⁻¹ (rpm) (43.0 H.P. / 2800 min ⁻¹ (rpm))
	SAE Intermittent H.P.	28.7 kW / 2800 min ⁻¹ (rpm) (38.5 H.P. / 2800 min ⁻¹ (rpm))
	SAE Cont. H.P.	24.6 kW / 2800 min ⁻¹ (rpm) (33.0 H.P. / 2800 min ⁻¹ (rpm))

Maximum Bare Speed	3000 min ⁻¹ (rpm)
Minimum Bare Idling Speed	800 min ⁻¹ (rpm)
Combustion Chamber	Spherical Type
Fuel Injection Pump	Bosch K Type mini pump
Governor	Centrifugal Ball Mechanical Governor
Injection Nozzle	DN 12SD 12
Injection Timing	0.436 rad. (25) before T.D.C.
Injection Pressure	13.73 MPa (140 kgf/cm ² , 1991 psi)
Compression Ratio	21
Cooling System	Pressurized radiator (8.83 x 1Q4Pa, 0.9 kgf/cm ² , 12.8 psi) Forced circulation (with water pump)
Starting System	Electric Starting with Cell starter (12V, 1.4kW)
Dynamo for Charging	12V, 300W
Fuel	Diesel Fuel No.2-D
Weight (Dry)	178.2kg (392.2lbs.)
Battery	12V, 110AH, equivalent
Direction of Rotation	Counter-clockwise from flywheel side
Application	General Power Source

Performance Curves

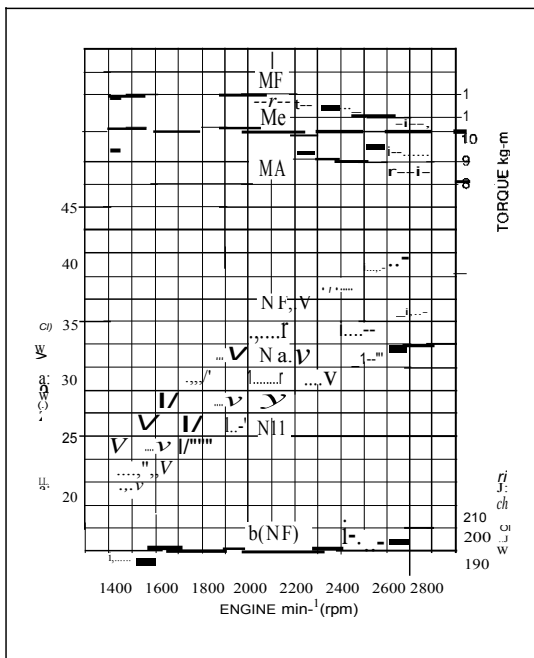

Note:
Each performance curves, obtained in accordance with DIN 6270 and DIN 70020, are corrected to 101kPa (760mmHg), and 20°C, 60% humidity.

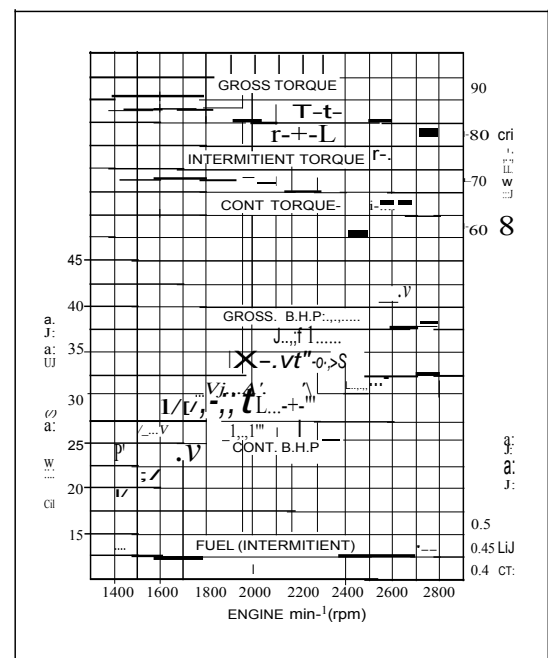

Note:
Each performance curves, obtained in accordance with SAE J816b, are corrected to 101kPa (760 mmHg), and 20° C, 60% humidity.

• DIMENSIONS

(01101-B, 01302-B, 01402-B)

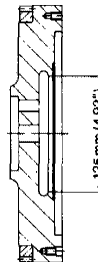
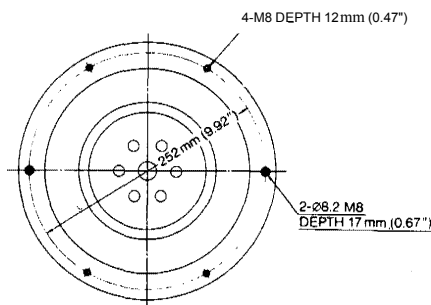
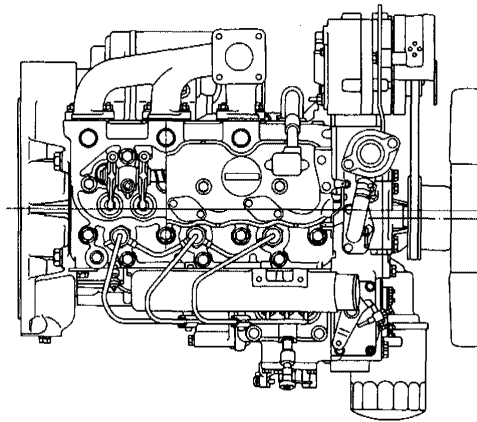
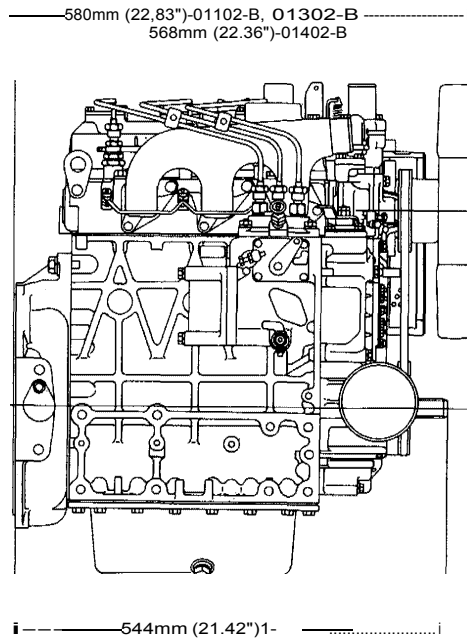
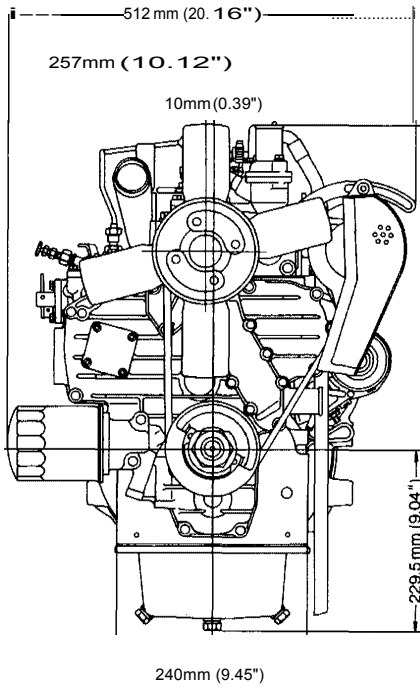

0073F013

(V1502-B, V1702-B, V1902-B)

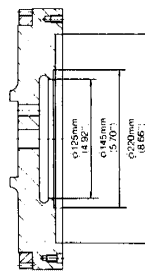
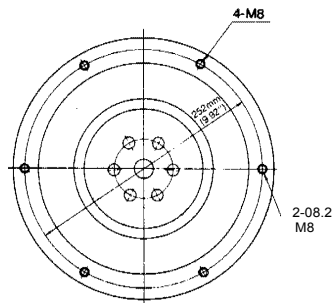
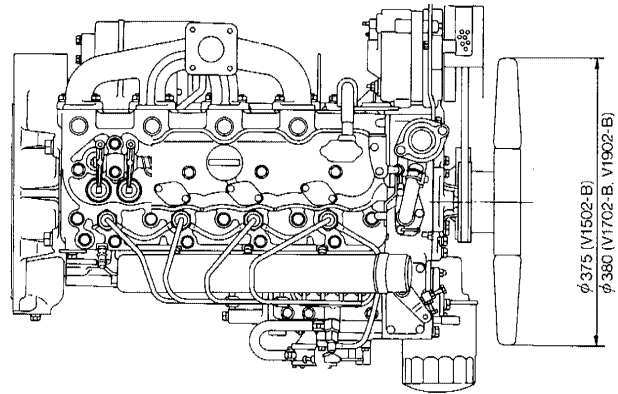
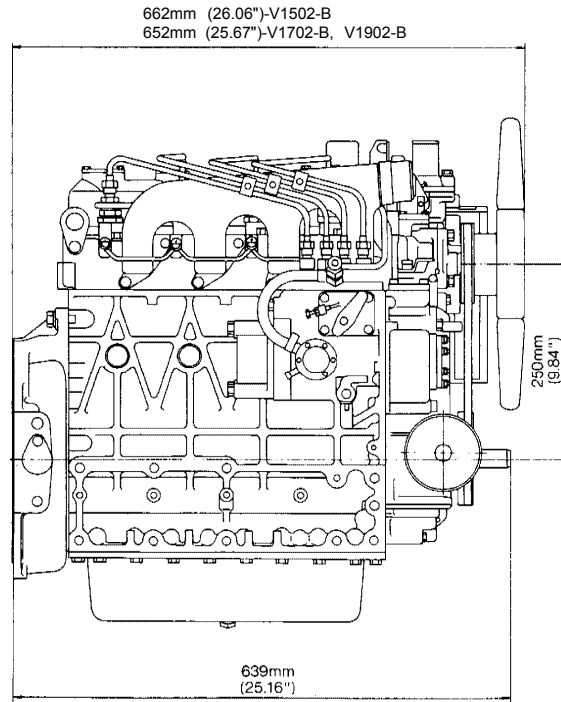
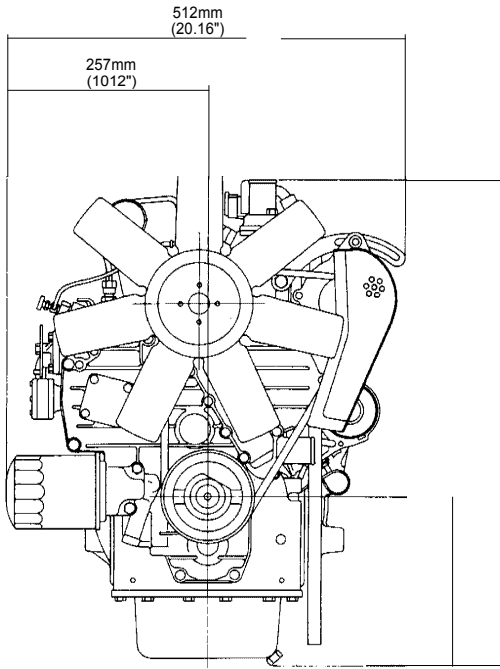

0073F014

Section II

GENEIIAt. DEIGRIPf:101

FEATURE	14	4. FUEL SYSTEM	
1. ENGINE		4.1 Fuel Filter (Optional Part)	19
1.1 Cylinder Block	16	4.2 Fuel Pump	20
1.2 Cylinder Head	16	4.3 Fuel Injection Pump	20
1.3 Piston and Piston Rings	17	4.4 Injection Nozzle	22
1.4 Inlet and Exhaust Valves	17	4.5 Governor	22
2. LUBRICATION SYSTEM.....	18	5. ELECTRICAL SYSTEM	
3. COOLING SYSTEM	18	5.1 Cranking System.....	23
		5.2 Charging System	25

FEATURE

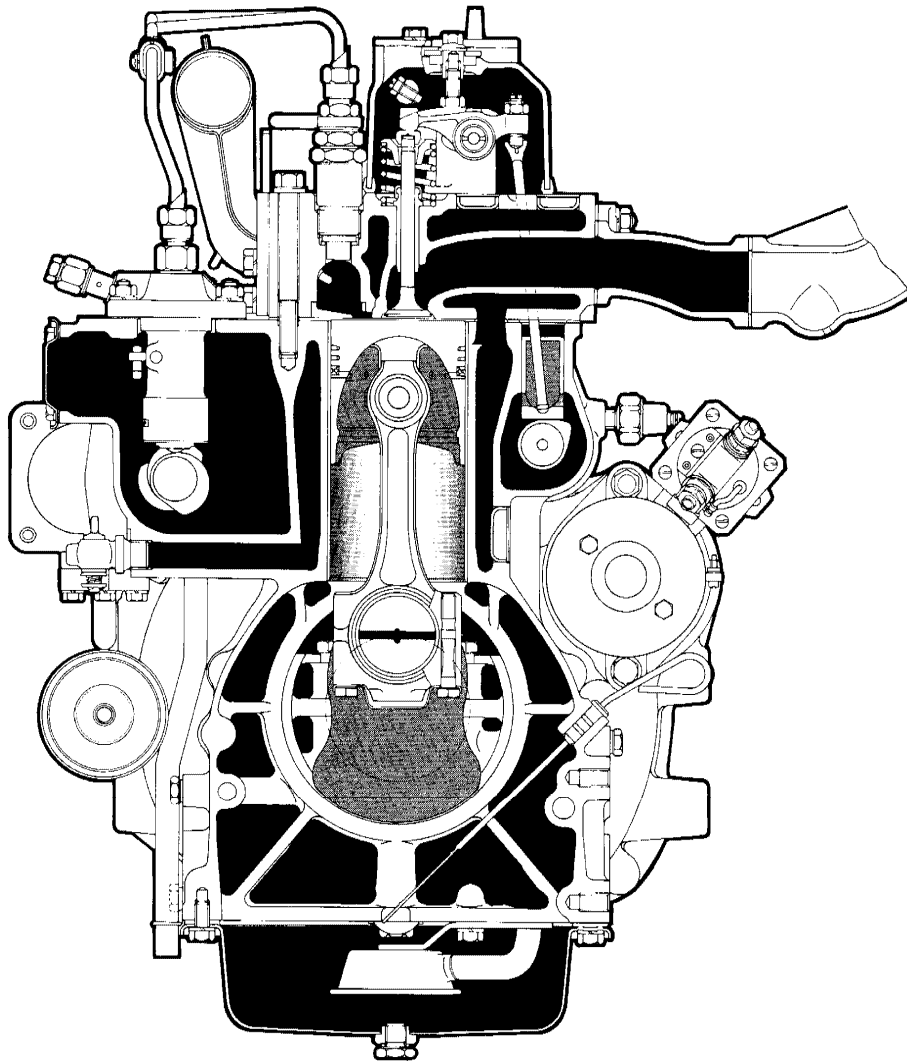

0073FO1 5

The D 1102-8, 01302-B, D 1402-B, V1502-B, V1702-B, V1902-B are water-cooled, 4-cycle diesel engines, they concentrate Kubota's foremost technologies. With Kubota's designed spherical combustion chamber, well-known Bosch K type injection pump, well-balance designs, they feature greater power, low fuel consumption, little vibration and limited noise.

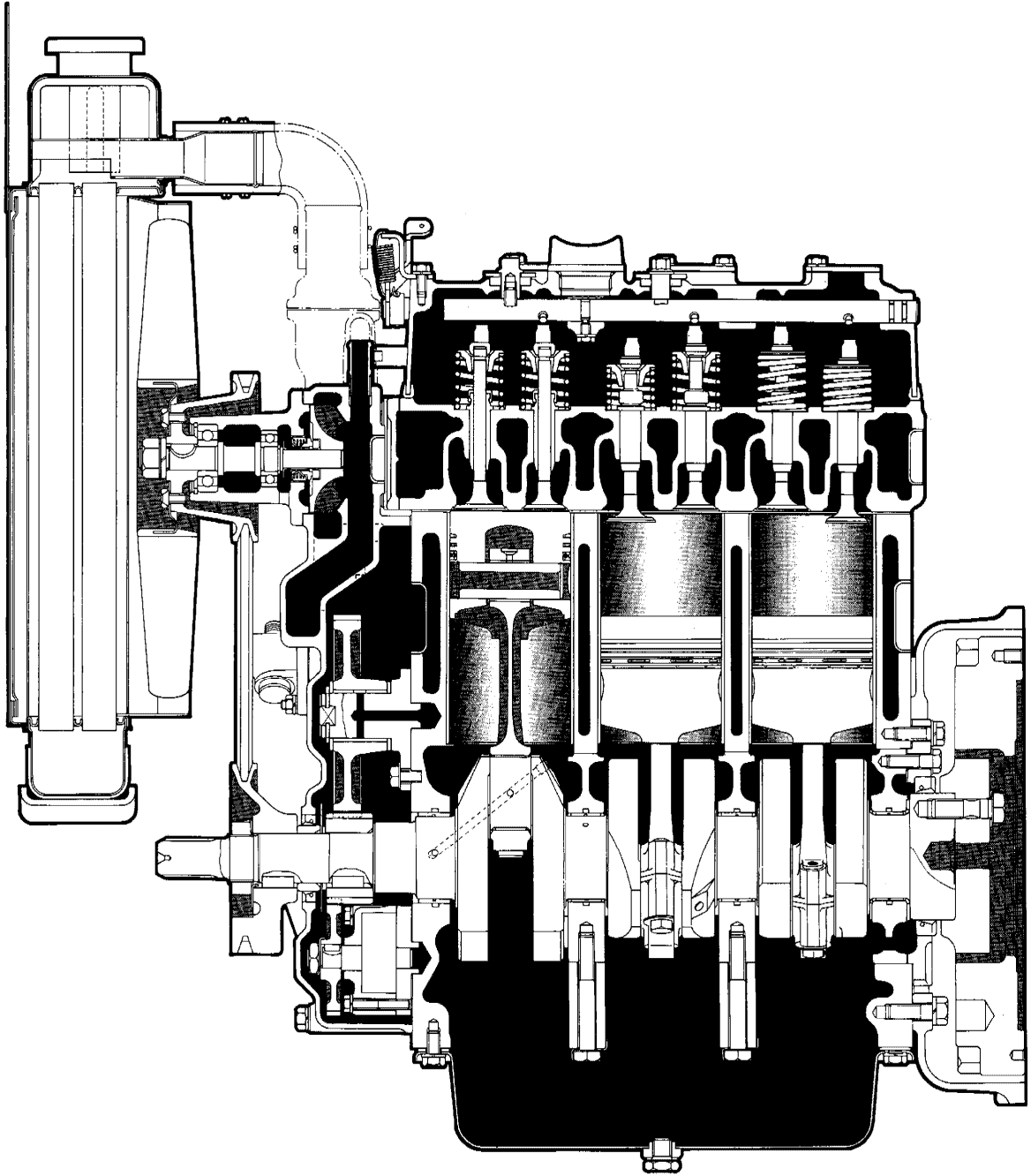

0073F016

1 ENGINE

(A) Tunnel Cylinder Block

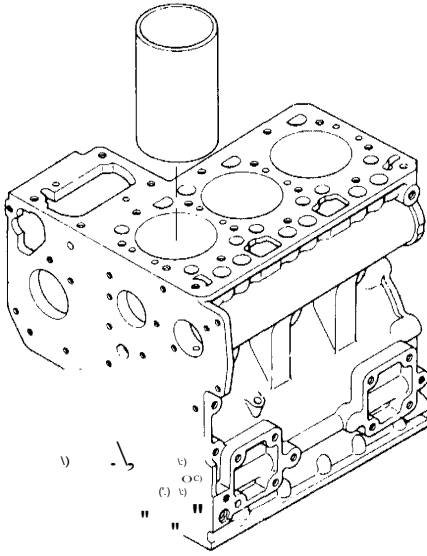

0011 F0J2

1-1 CYLINDER BLOCK

The engine features a high durability tunnel-type cylinder block. Furthermore, dry-type cylinder liners are pressure-fitted into cylinders allowing effective cooling, less distortion, higher wear-resistance quality and each cylinder has its own chamber helps to minimize noise.

(A) Cross-Flow Type Cylinder Head

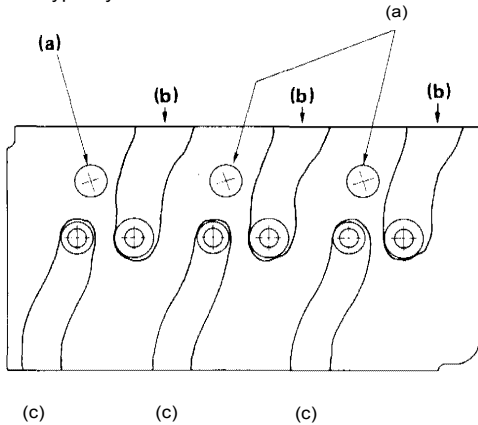

0011 F014

1-2 CYLINDER HEAD

To prevent the effect of air expansion due to exhausted heat, cross-flow type inlet and exhaust ports are provided. The Kubota's exclusive spherical combustion chamber (e) changes the entered air into a swirling flow to improve combustion and reduce fuel consumption. In addition, the sheathed type glow plugs (c) permit easy and quick engine start, regardless of weather condition, even when the temperature is -15°C (5°F).

- (a) Combustion Chamber
- (b) Suction
- (c) Exhaust

(B) Combustion Chamber

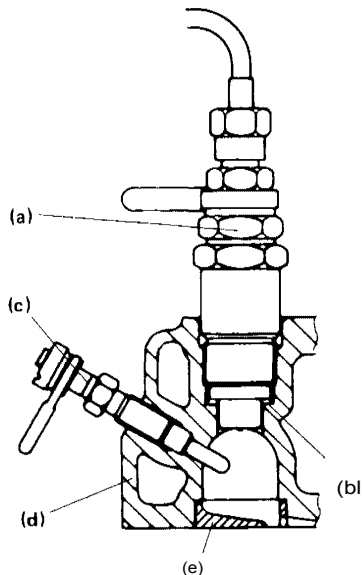

0011 F013

- (a) Nozzle Assembly
- (b) Nozzle Piece Gasket
- (c) Glow Plug
- (d) Cylinder Head
- (e) Combustion Chamber

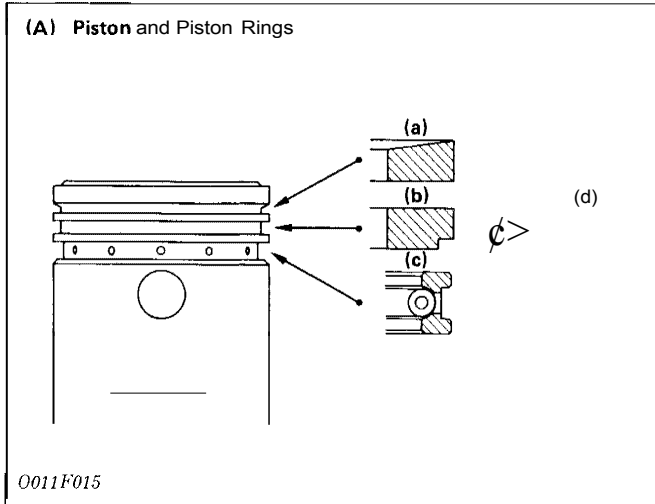

1-3 PISTON AND PISTON RINGS

A piston of special elliptic shape is designed in consideration of explosion heat. Further more, to enhance piston's strength, a rib is provided between the piston and the piston boss. Three piston rings are provided; two compression rings and one oil ring. All of them have different functions and shapes. Be careful when reassembling.

- (a) Plated Keystone Ring
- (b) Undercut Ring
- (c) Coil Expander Ring
- (d) Taper and Inside Cut Ring

V1702-B Only

Engine Serial Number : 37196 and beyond, J

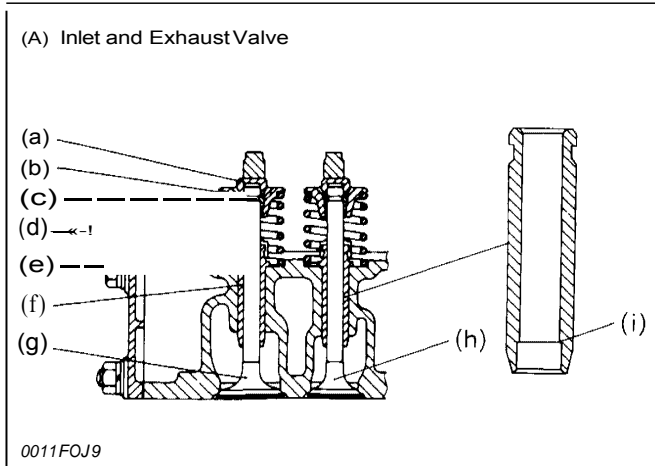

1-4 INLET AND EXHAUST VALVES

All parts are quenched and tempered to resist wear. For enhancing the filling-up of air into engine, the inlet valve head is bigger than the exhaust (h) one. To prevent the carbon adhesion on exhaust valve stem, a "carbon-scraper" (i) is provided at the lower part of exhaust valve guide.

- (a) Valve Cap
- (b) Valve Spring Retainer
- (c) Valve Spring Collet
- (d) Valve Spring
- (e) Valve Stem Seal
- (f) Valve Guide
- (g) Inlet Valve
- (h) Exhaust Valve
- (i) Carbon Scraper

2 LUBRICATION SYSTEM

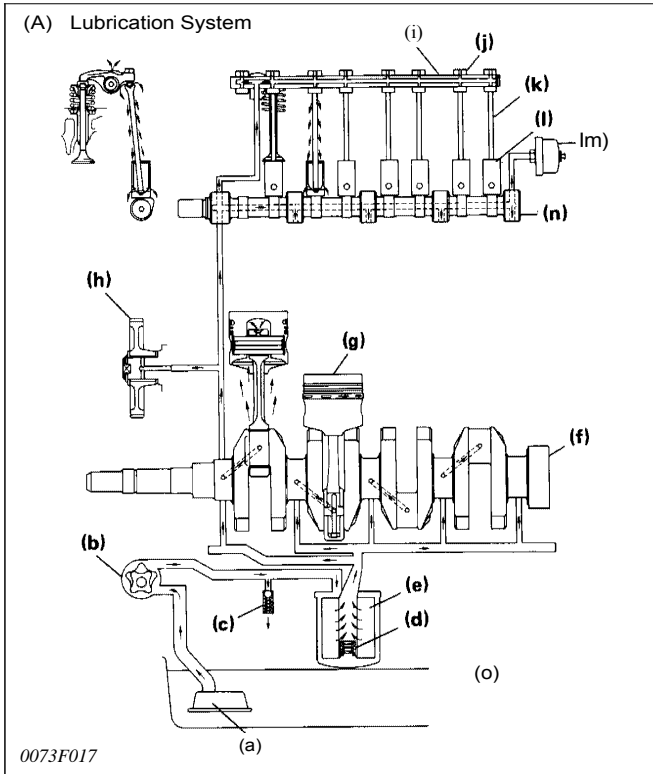

- | | |
|-------------------------------|-------------------------|
| (a) Oil filter | (i) Rocker arm shaft |
| (b) Oil pump | (j) Rocker-arm |
| (c) Pressure regulating valve | (k) Push rod |
| (d) By-pass valve | (l) Tappet |
| (e) Filter element | (m) Oil pressure switch |
| (f) Crankshaft | (n) Camshaft |
| (g) Piston | (o) Oil pan |
| (h) Idle gear | |

The lubrication system consists of a trochoid rotor-type driven oil pump, oil filter cartridge, oil pressure regulating valve, oil switch and oil filter.

Oil is sucked by the oil pump (b) from the oil pan (o) through the oil filter (a), and the oil is kept at 294 to 441 kPa (3.0 to 4.5 kgf/cm², 42 to 64 psi) by an oil pressure regulating valve (c) installed in the gear case. Then oil flows towards the filter cartridge where it will be further filtered — To ensure the supplying of lubricated oil, a by-pass valve (d) is provided, the valve opens when the filter element (e) is restricted — From the filter cartridge, the pressured oil is then distributed into two parts: one part will be fed through crankshaft passage to the crank pin bearing and the other to the rocker arm shaft (i) through the frame. Oil then returns to oil pan by force of gravity.

An oil pressure switch (m) is provided on the way for watching the oil pressure drop. The oil pressure switch can be connected to the terminals of the warning lamp on the hour-meter unit (optional part), the light will be light for warning the operator if the oil pressure drops below 50 kPa (0.5 kgf/cm², 7.1 psi).

If the warning lamp remains light while engine is at normal operation, stop the engine immediately and check the oil pressure.

3 COOLING SYSTEM

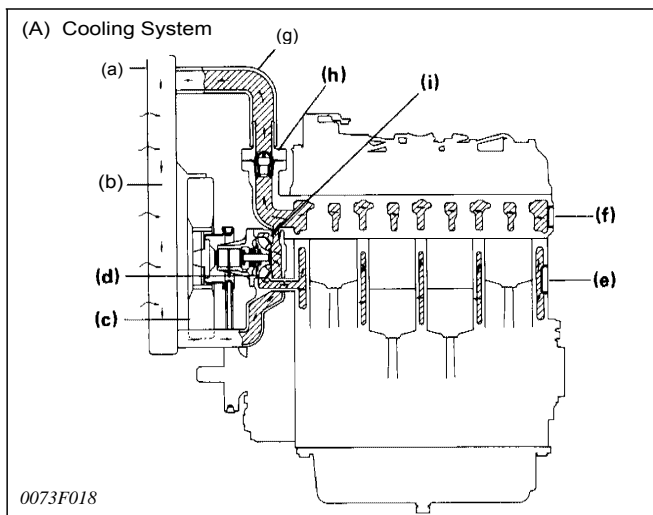

- | | |
|--------------------|-------------------|
| (a) Radiator | (f) Cylinder head |
| (b) Radiator core | (g) Water pipe |
| (c) Suction fan | (h) Thermostat |
| (d) Water pump | (i) By-pass |
| (e) Cylinder block | |

The cooling system consists of a radiator (optional part), centrifugal water pump, suction fan and thermostat.

The water flow is cooled through the radiator core (b) and the fan (c) set behind the radiator (a) pulls cooling air through the core to improve cooling.

The pump (d) sucks the cooled water, forces it into the cylinder block (e) and draws out the hot water. Then the cooling is repeated. Furthermore, to control temperature of water, a thermostat (h) is provided on the way. When the thermostat opens, the water moves directly to radiator, but when it closes, the water moves toward the water pump through the by-pass (i) between thermostat and water pump. The opening temperature of thermostat is about 82°C (176.3°F).

4 FUEL SYSTEM

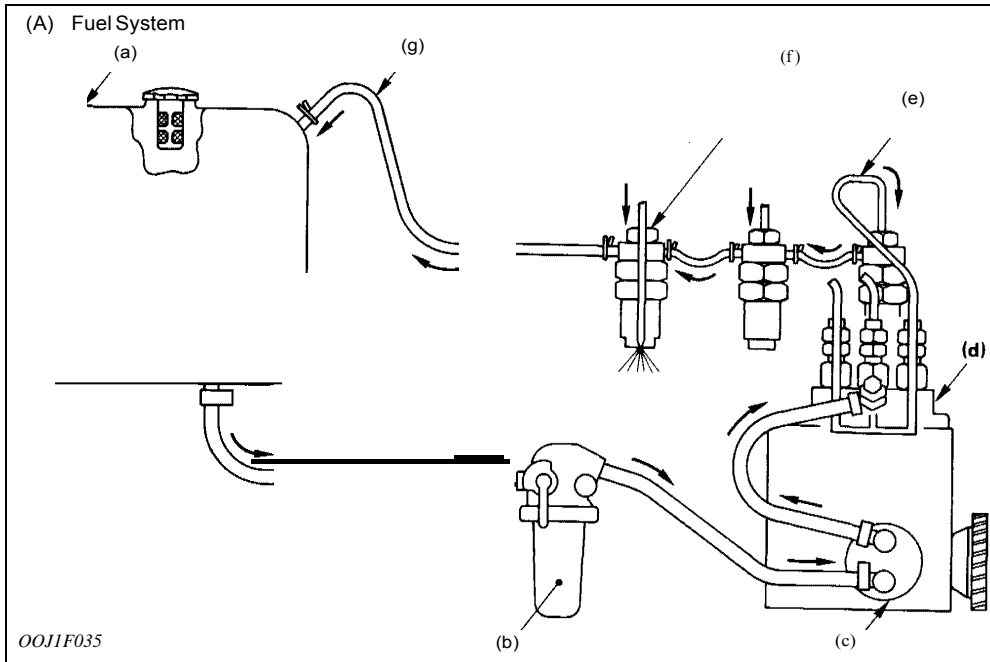

- | | |
|--------------------|------------------------|
| (a) Fuel Tank | (e) Injection Pipe |
| (b) Fuel Filter | (f) Injection Nozzle |
| (c) Fuel Pump | (g) Fuel Overflow Pipe |
| (d) Injection Pump | |

In operation, fuel from the fuel tank (a) enters the filter (b), where it is cleaned and absorbed by the suction of fuel pump (c). (V1502-B, V1702-B, V1902-B are available) The pump then pushes it to the injection pump (d), where it is pressurized under high pressure and through the injection pipe (e), it is delivered to each injection nozzle (f), which atomizes and injects it into the combustion chamber at the proper time and amount. Excessive fuel from nozzles returns to the fuel tank through fuel overflow pipe (g).

(A) Fuel Filter

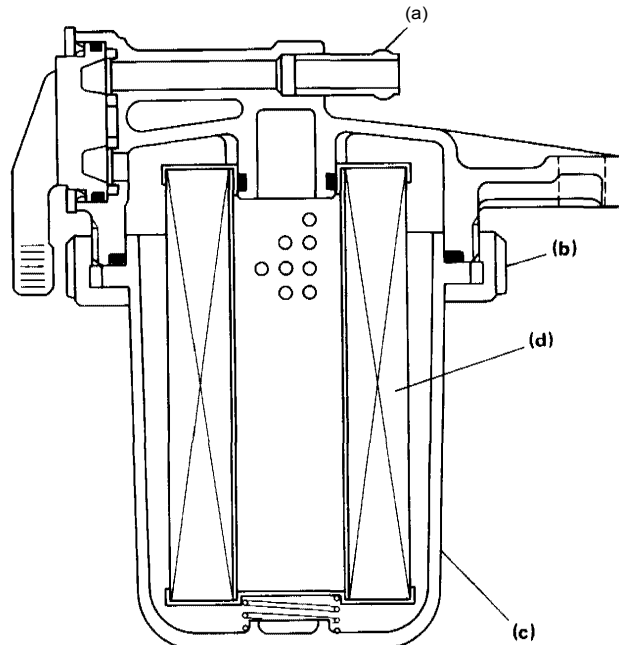

- | |
|--------------------|
| (a) Cock Body |
| (b) Retaining Ring |
| (c) Filter Cup |
| (d) Element |

4-1 FUEL FILTER (OPTIONAL PART)

For protecting injection pump and injection nozzles from impurities, the fuel is sent through the filter before reaching the fuel pump.

Fuel enters the filter, passes through the filter element (d) circumference toward the center for filtering. The filtration granular size is from 10 to 20 μ m (0.01 to 0.02mm).

4-2 FUEL PUMP

The fuel pump sucks the filtered fuel and forces it under pressure to the injection pump. Sucking and discharging are done by the vertical movement of the diaphragm (b), which is operated by a cam of the fuel camshaft (a). Fuel is sucked on the downward stroke and discharged on the upward stroke.

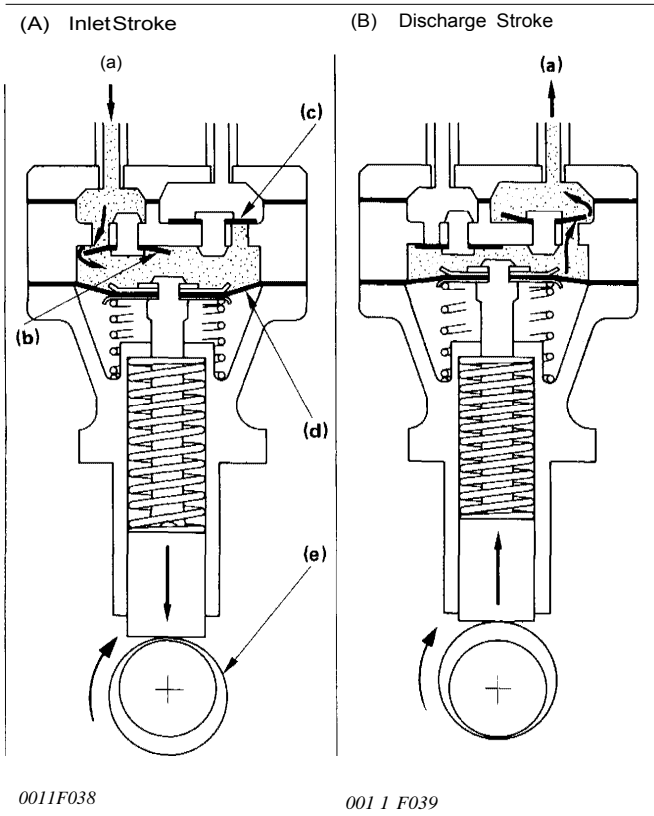

- 0011F038 0011F039
- (a) From Fuel Filter (a) To Injection Pump
 (b) Inlet Valve
 (c) Outlet Valve
 (d) Diaphragm
 (e) Fuel

4-3 FUEL INJECTION PUMP

The well-known Bosch K type mini pump is provided, it features high injection quality even at low engine speed, and the injection timing could be changed easily by adjusting the number of shim.

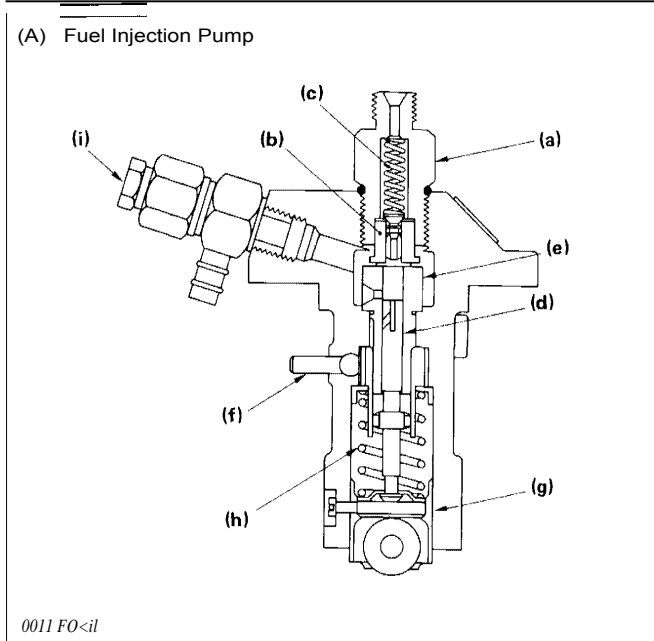

- (A) Fuel Injection Pump
- (a) Delivery Valve Holder
 (b) Delivery Valve
 (c) Delivery Valve Spring
 (d) Plunger Pump Element
 (e) Cylinder Pump Element
 (f) Control Rack
 (g) Tappet
 (h) Plunger Spring
 (i) Air Vent Screw

(A) Pressurization of Fuel

- (a)
- (b)
- (c)
- (d)
- (e)
- (f)

Fig. 1

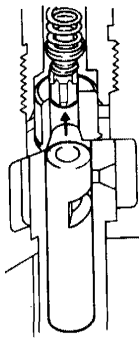

Fig. 2

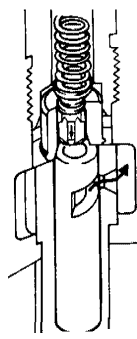
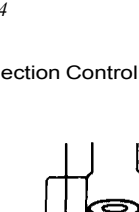

Fig. 3



0011F044

(A) Injection Control

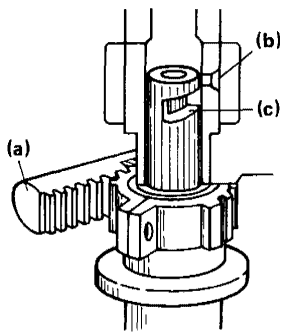

Fig. 1

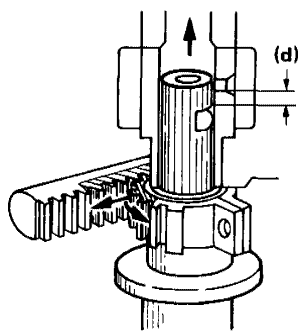
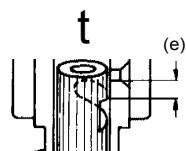

Fig. 2



How it works:

- 1) When the plunger is at the bottom of its stroke, fuel from the fuel chamber enters the delivery chamber through the feed hole (Fig. 1)
- 2) As the camshaft rotates, plunger moves upward, the stroke of fuel pressurization begins. (Fig. 2)
- 3) As the plunger moves up, the pressure increases until it opens the delivery valve and sends the pressurized fuel to injection nozzle through the injection pipe. (Fig. 3)
- 4) Sending of fuel stops as soon as the control groove meets the feed hole. Fuel flows out through the plunger's center hole, control groove and feed hole, then backs to the fuel chamber. As a result, the pressure falls and the stroke is completed. (Fig. 4)

(A) Pressurization of fuel

- (a) Delivery Chamber
- (b) Delivery Valve
- (c) Feed Hole
- (d) Fuel Chamber
- (e) Plunger
- (f) Control Groove

Quantity control of fuel injection

1) No fuel

The feed hole meets the control-groove before being closed by the plunger top. Therefore, no fuel is pressurized and injected. (Fig. 1)

2) Partial fuel

Plunger rotates a certain amount when the control rack is moved in the direction of the arrow. Effective stroke A means the distance which the feed hole is closed by the plunger before meeting the control groove on the plunger. Therefore, fuel is injected as much as the amount of effective stroke. (Fig. 2)

3) Maximum fuel

As the control rack moves the greatest possible amount in the direction of the arrow, the effective stroke A is maximum and the maximum amount of fuel is injected. (Fig. 3)

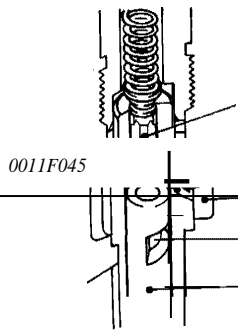
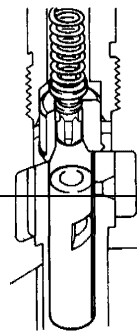

Fig. 3



- (a) Control rack
- (b) Feed hole
- (c) Control groove
- (d) Effective Stroke
- (e) Effective Stroke maximum

21

(A) Injection Nozzle

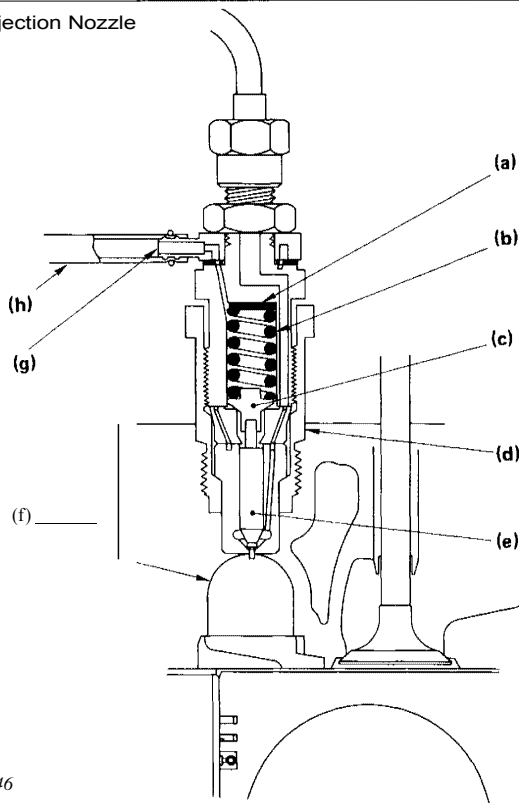

0011F046

4-4 INJECTION NOZZLE

The nozzle is a throttle-type one, it features low fuel consumption and works well with Kubota's spherical combustion chamber.

The nozzle valve opening pressure is about 13.7 to 14.7 MPa (140 to 150 kgf/cm², 1990 to 2130 psi), the pressure overcomes the counterforce of nozzle valve spring (b), and push the valve (e) up instantly, the fuel is then injected in a proper quantity into the swirling air in the combustion chamber (f) for combustion. Addition or reduction of shim can adjust the opening pressure. A shim of 0.1 mm corresponds to 98.0 kPa (10 kgf/cm², 142 psi) change in opening pressure.

- (a) Adjusting Washer
- (b) Nozzle Spring
- (c) Push Rod
- (d) Nozzle Nut
- (e) Needle Valve
- (f) Combustion Chamber
- (g) Fuel Overflow Nipple
- (h) Fuel Overflow pipe

(A) Governor

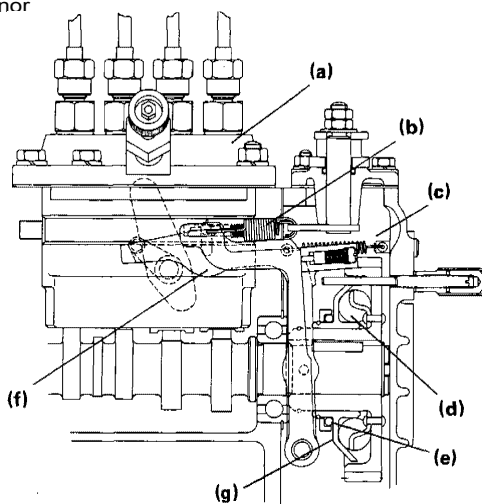

0073F020

4-5 GOVERNOR

The engine features Kubota's exclusive ball-type variable speed governor and a torque spring is provided to improve engine torque performance and to prevent engine from stalling in case of overload.

How it works:

When the speed control lever is set at its maximum position, the governor spring (b) pulls the control rack toward the maximum quantity through fork levers 1 and 2 (e, f). But as the engine speed increases, the governor balls (d) on the camshaft, by its centrifugal force, move outward and push back the fork lever 1 and 2 through the governor sleeve (g). The control rack position will be decided when the force created by governor balls equals the counterforce of the governor spring.

As the engine speed decreases, the centrifugal force diminishes and the balls move inward. As a result, the governor spring tension pulls the control rack for increasing the fuel. Due to the balance between spring tension and centrifugal force of governor balls, a nearly constant engine speed is obtained.

- (a) Injection pump
- (b) Governor spring
- (c) Torque spring
- (d) Governor balls
- (e) Fork lever 2
- (f) Fork lever 1
- (g) Governor sleeve

5 ELECTRICAL SYSTEM

(A) Electrical System

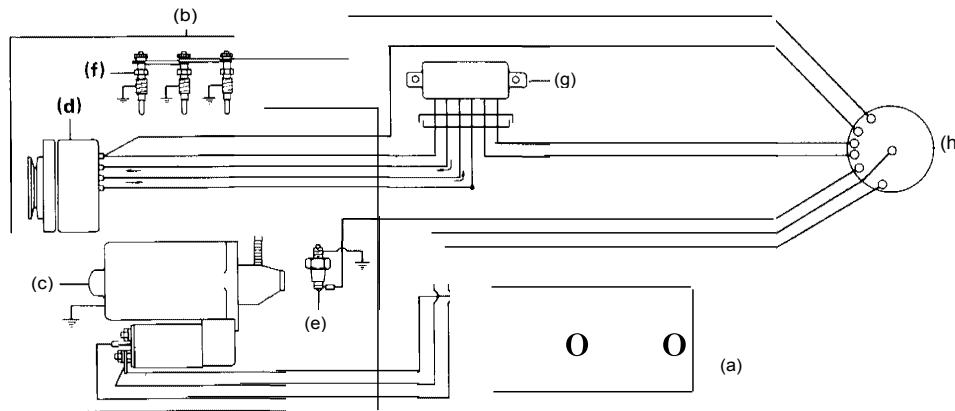

0073F021

(A) N-30 Construction

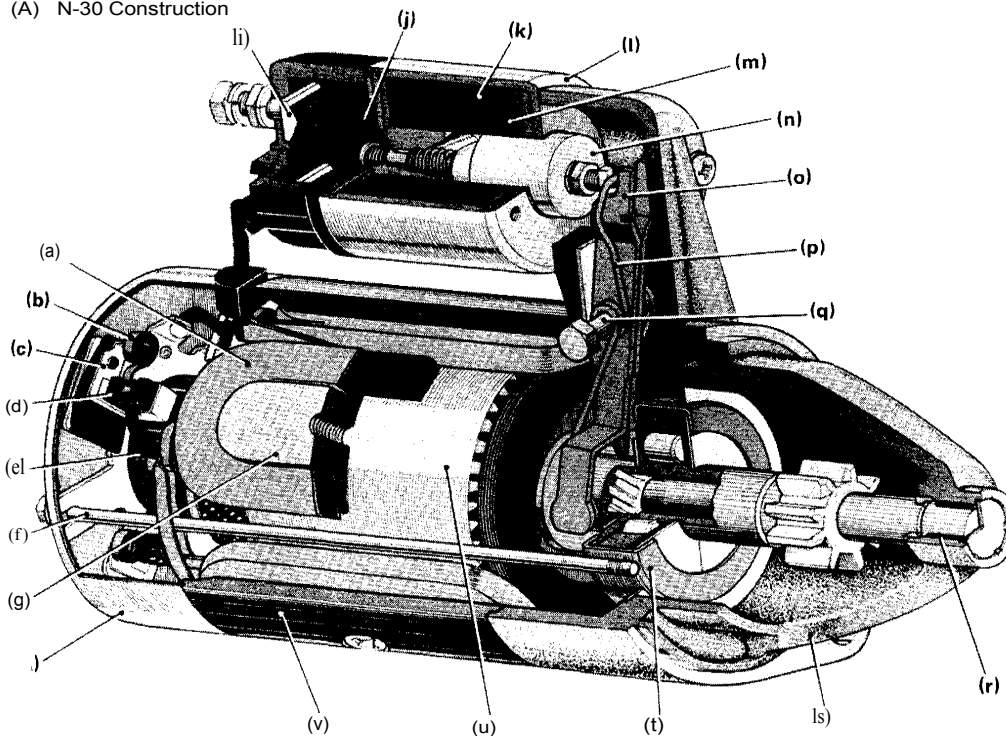

0011?237

- | | |
|-------------------|------------------------|
| (a) Field Coil | (l) Magnet Switch |
| (b) Brush Spring | (m) Pull-in Coil |
| (c) Brush Holder | (n) Moving Core |
| (d) Brush | (o) Drive Lever |
| (e) Commutator | (p) Drive Spring |
| (f) Through Bolt | (q) Lever Set Bolt |
| (g) Pole Core | (r) Bearing |
| (h) End Frame | (s) Drive Side Housing |
| (i) Contact Bolt | (t) Overrunning Clutch |
| (j) Contact Plate | (u) Armature |
| (k) Holding Coil | (v) Yoke |

5-1 CRANKING SYSTEM

The cranking system consists of a battery of 12V, magnet starter, glow plugs and a coil switch.

1) Starter

The magnet-switch type starter is composed of two main sections.

The first section converts electrical energy into mechanical rotation to turn the engine crankshaft. It is composed of the field coil, armature, brush, commutator, pinion, overrunning clutch, etc.

The second section allows the pinion and flywheel to engage together and current to flow through the motor section. It is composed of the pull-in coil, holding coil, plunger, drive lever, contact plate, etc.

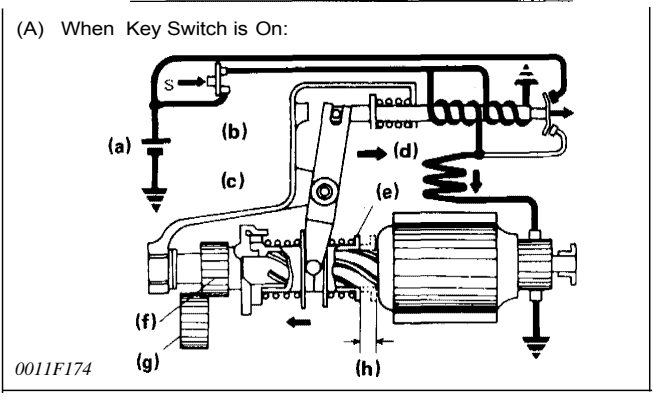
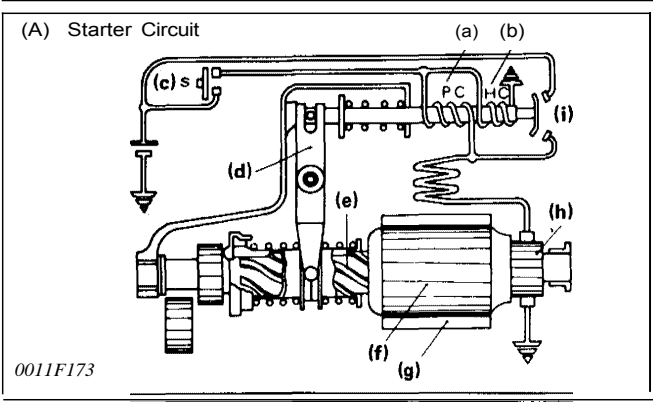

How it works:

- When Key Switch is On:

When the key switch is turned on, a current flows from the battery through the pull-in coil in the magnet switch section to the holding coil, energizing the plunger to pull it in. At this time, the pinion moves by the drive lever to engage with the ring gear.

- | | |
|--------------------|-----------------------|
| (a) Battery | (e) Spline Tube |
| (b) Starter Switch | (f) Pinion |
| (c) Ground | (g) Ring Gear |
| (d) Return Spring | (h) Operated by Lever |

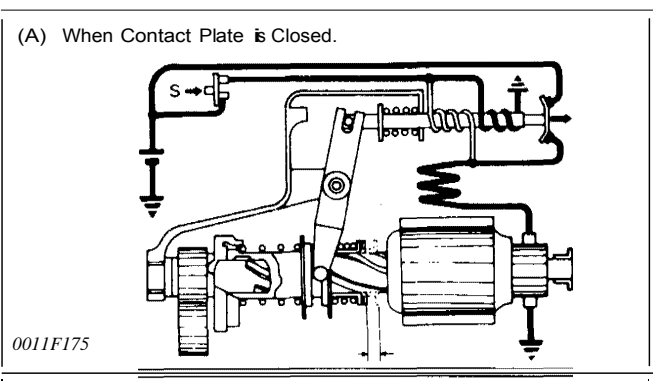

- When Contact Plate Is Closed:

When the contact plate is closed, a large current flows through the motor section to generate a large mechanical power which turns the engine crankshaft. At this time, the pinion is moved forward by the screw spline for more contact. Since the pull-in coil ends are short-circuited by the contact plate, the plunger is held only by the force of the holding coil.

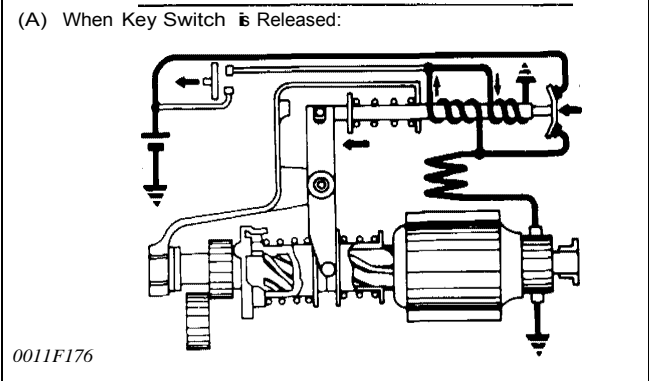

- When Key Switch Is Released:

When the key switch is released, a current flows instantaneously through the pull-in coil in the opposite direction as shown in Fig. Therefore, the forces of the holding coil and pull-in coil are balanced. As a result, the plunger is returned by the return spring. Simultaneously, the pinion is disengaged from the ring gear, the contact plate is disconnected, and the starter is promptly stopped by the armature brake.

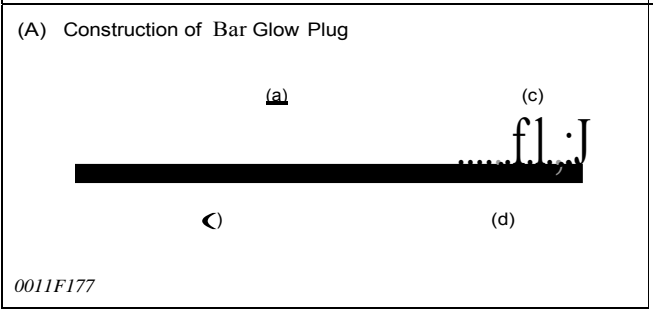

2) Glow plug

A glow plug is used for each pre-combustion chamber of the cylinder head to make starting easier.

- | | |
|-----------------------|----------------|
| (a) Insulating Powder | (c) Heat Coil |
| (b) Housing | (d) Metal Tube |

(A) Alternator

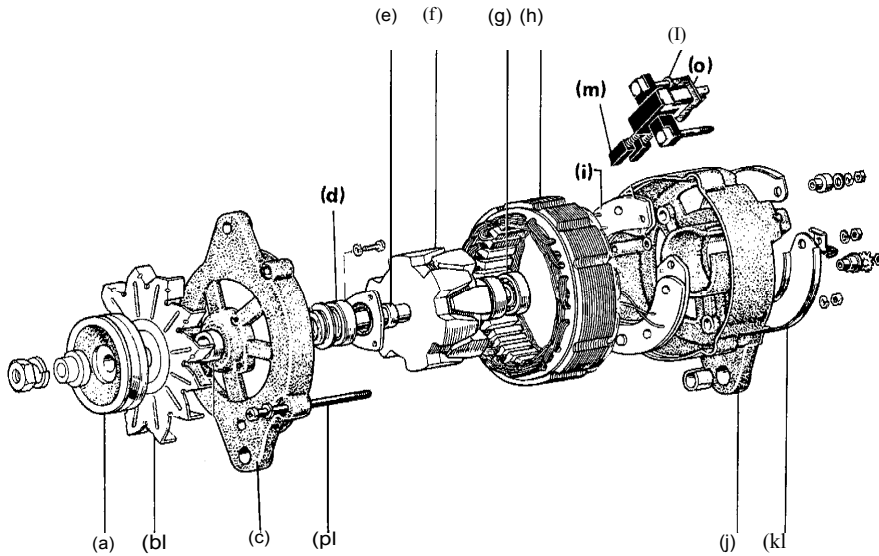

0073F022

- | | | | |
|--------------|----------------|---------------|----------|
| (a) Pulley | (f) Armature | (kl) Cover | (p) Bolt |
| (bl) fan | (g) Bearing | (ll) Holder | |
| (c) Frame | (hi) Yoke | (m) Brush | |
| (di) Bearing | (ii) Rectifier | (nl) Spring | |
| (el) Spacer | (j) Frame | (o) Insulator | |

5-2 CHARGING SYSTEM

The charging system consists of an AC alternator and a regulator (option). The alternator generates AC (Alternating Current) and the regulator converts AC into DC (Direct Current), also controls the output voltage for charging current to the battery.

1) Alternator

The AC alternator produces higher voltage in slow speed, compared with DC dynamo and charges more current to battery even during engine idling. The provided alternator is an alternating current generator containing a rectifier. Alternating current is induced in a stator coil by rotating magnetic poles around the coil. The alternating current is then rectified into a direct current through diodes.

2) Regulator (optional part)

The regulator converts AC into DC, also regulates the charging voltage. Since the alternator speed is varied by engine speed variation, the output voltage from an alternator varies. However, constant voltage (12V) must be supplied to the battery. That is the regulator which works to keep the charging voltage at 12V.

[Note]

- A regulator of 13.8V to 14.8V must be used.

(A) Regulator

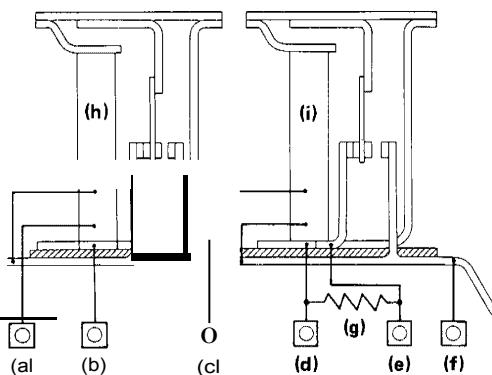

- | |
|----------------------|
| (a) N terminal |
| (b) L terminal |
| (c) B terminal |
| (d) F terminal |
| (e) IG terminal |
| (f) E terminal |
| (g) Control resistor |
| (h) Pressure coil |
| (i) Voltage coil |

0073F023

Section III

ENGINE

1. TROUBLESHOOTING	28	3. SERVICING	
2. DISASSEMBLY AND REASSEMBLY		Cylinder Head	49
Cylinder Head	35	Fuel System	55
Fuel Injection Nozzle	37	Timing Gear, Camshaft	59
Gear Case, Timing Gear, Camshaft, Oil Pump ..	39	Lubrication	60
Thermostat, Water Pump	43	Piston, Connecting Rod	62
Piston, Crankshaft	45	Crankshaft	63
		Cooling System	70
		Cylinder Liner	69

1.TROUBLESHOOTING

ENGINE DOES NOT START.

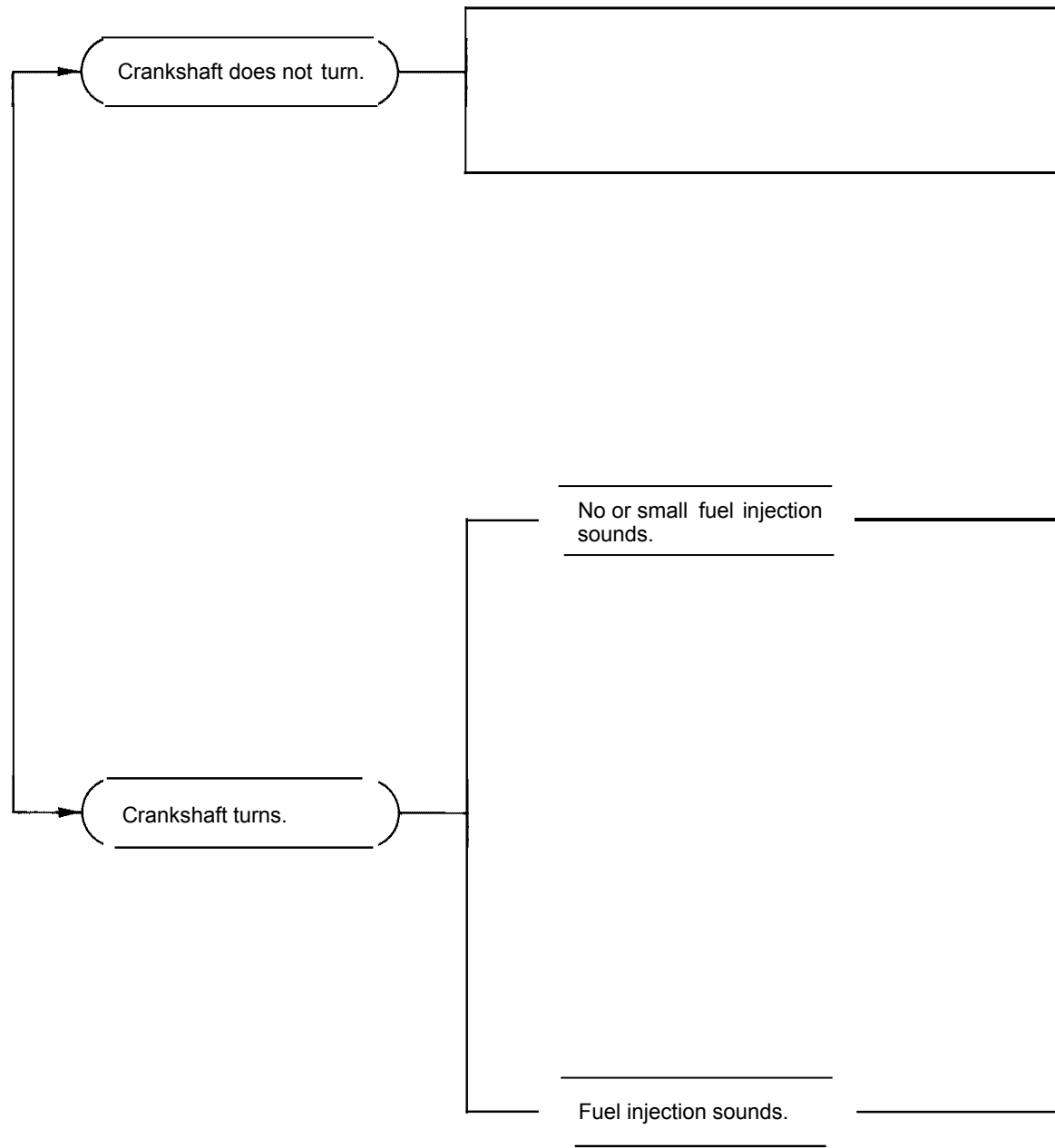

Frictional resistance of moving parts is too much.	Crankshaft and camshaft have seized up.	59,63
	Piston and cylinder liner have seized up.	62,68
	Bearings are oil-stuck.	48
	Lubrication system not working properly.	60

r L	Starter faulty.	85
	Battery capacity is low or terminal loose.	

ri	Fuel supply to injection pump is insufficient.	Fuel pipe broken.	
		Air enters fuel pipe through connection.	
		Fuel filter clogged.	58
		Fuel pump faulty.	42

ri	Injection pump does not send on fuel.	Control rack stays at non-injection point.	38
		Plunger is worn or seized up.	57
		Delivery valve not completely oil-tight.	57

ri	Fuel does not inject through injection nozzle.	Needle valve stuck.	55,56
		Nozzle spring broken.	55,56
		Injection pressure maladjusted.	55,56
		Injection pipe mounting nut loose.	37

ri	Injection mistimed.	Injection timing maladjusted.	58
----	---------------------	-------------------------------	----

ri	Compressed air leaks.	Contact between intake/exhaust valve and seat not tight.	51
		Intake/exhaust valve spring broken.	52
		Intake/exhaust valve stuck.	52
		Gasket faulty.	36
		Tightness torque of cylinder head not enough.	36
		Piston ring stuck.	63
		Piston ring worn.	62
		Cylinder liner worn.	68
Tightness torque of injection nozzle and glow plug not enough.	37		

y	Valve actuation timing improper.	Valve clearance excessive.	54
---	----------------------------------	----------------------------	----

**ENGINE DOES NOT
TURN NORMALLY.**

Revelution irregular.

Revolution is not smooth
at high speeds.

Idling not smooth.

INSUFFICIENT.

Slow engine revolutions.

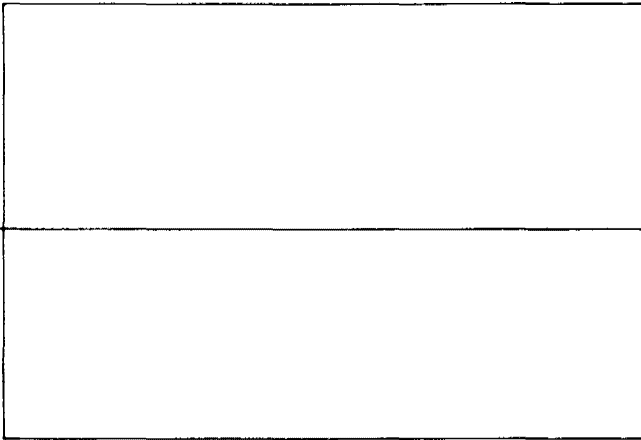

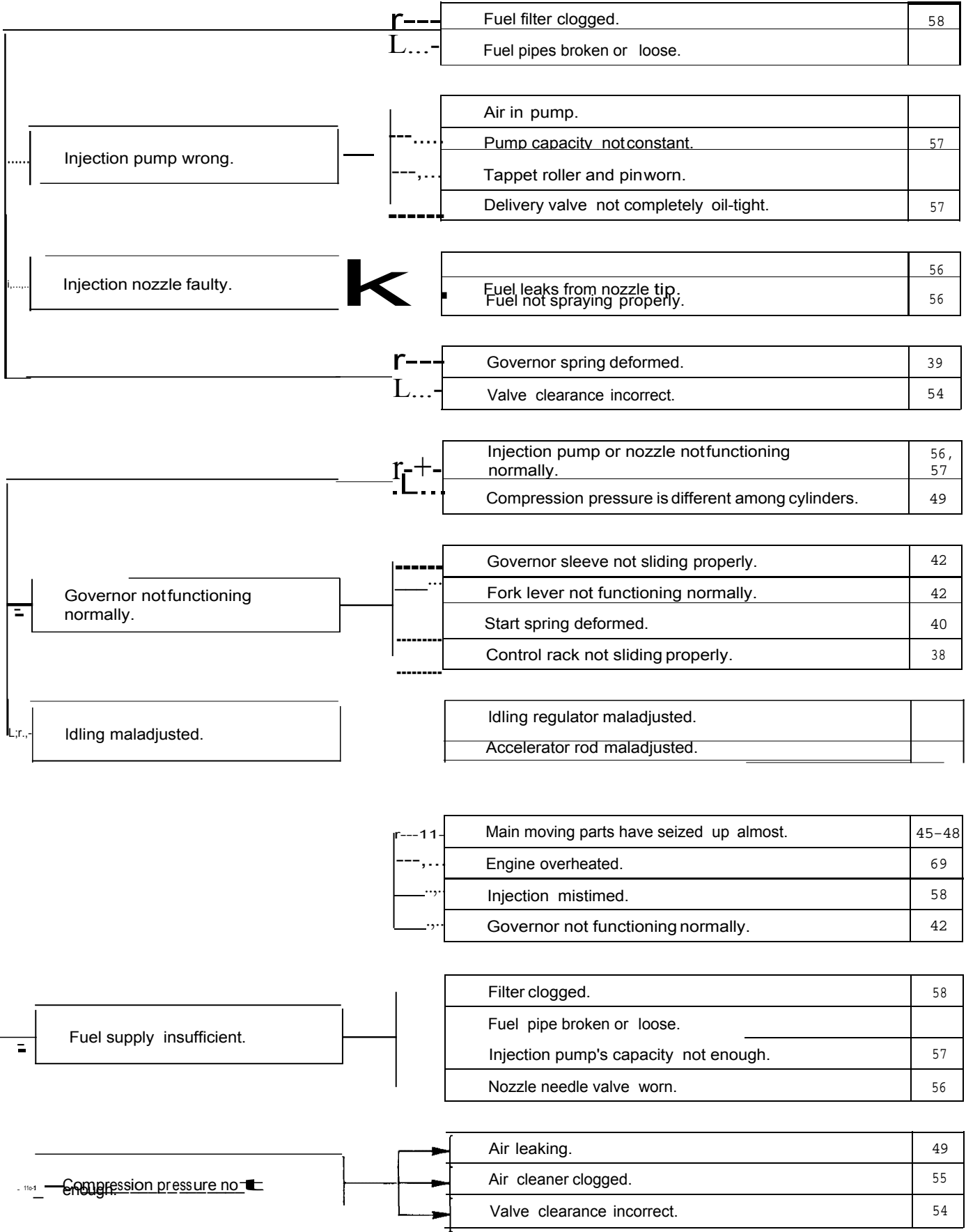

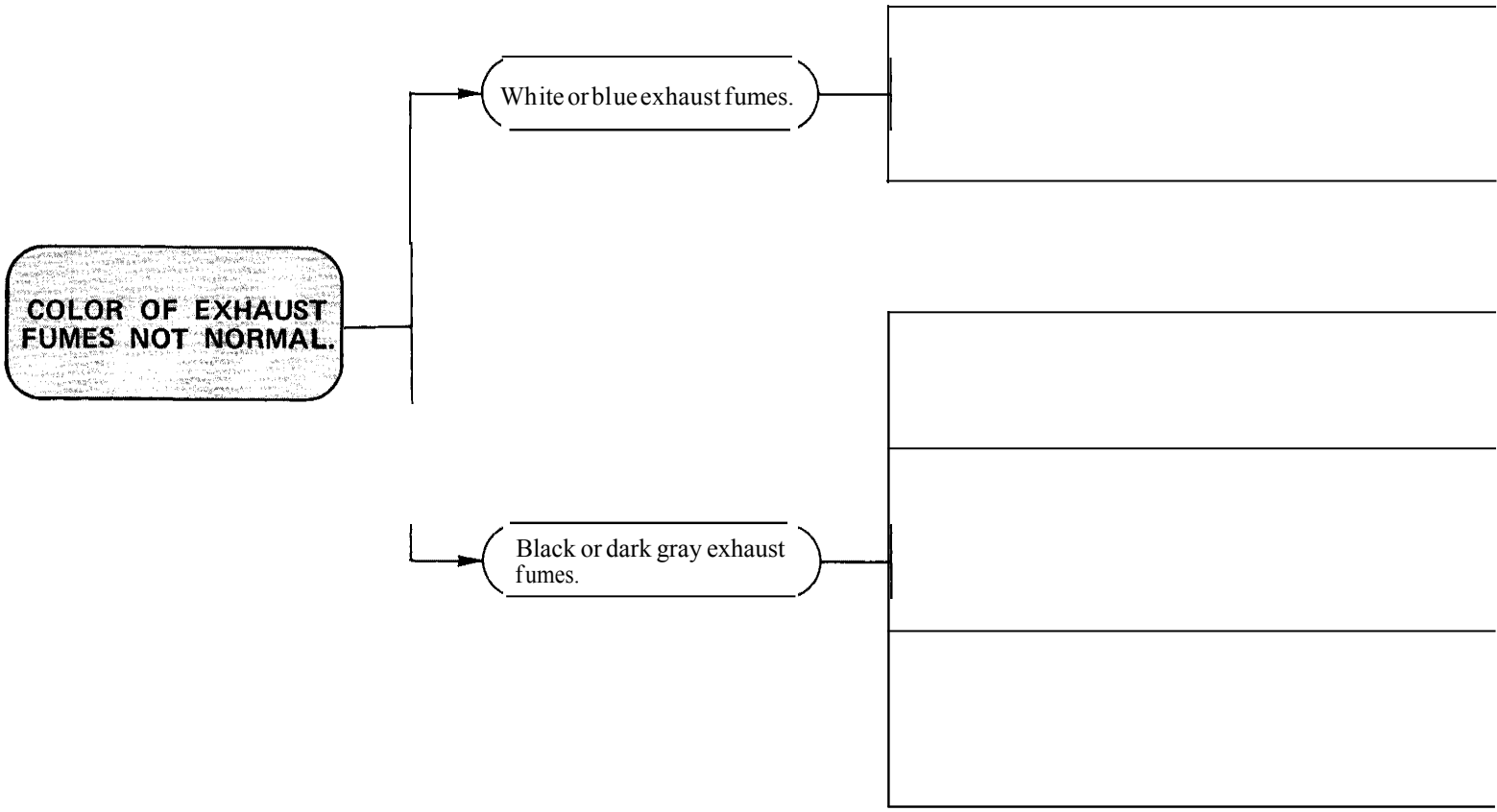

- Lubricant rises through piston gap.	-	Piston ring stuck.	63
	-	Piston ring worn.	62
	-	Excessive gap between cylinder liner and piston.	62,69
	-	Too much oil.	

-	→	Injection delayed.	58
	→	Compression pressure insufficient.	49

- Injection mistimed.	-	Injection too early.	58
	-	Injection delayed.	58

- Fuel pump's injection capacity varying.	-	Pump does not return completely because spring is stuck or broken.	
	-	Pump worn.	57

- Nozzle does not inject fuel properly.	-	Needle valve stuck.	56
	-	Nozzle spring broken.	56
	-	Too much carbon sticks to nozzle tip.	56
	-	Injection pressure too low.	56

-	-	Compressed air leaks.	49
	-	Air not enough.	55

-	-	Excessive gap between piston and liner.	
	-	Piston ring stuck.	63
	-	Piston ring worn.	62
	-	Excessive gap between intake/exhaust valve and valve stem.	52
	-	Valve stem seal broken.	36
	-	Oil leaks from defective packings.	

Fuel in lubricant.	→	Injection pump plunger leaks much fuel.	
	→	Fuel pump leaks much fuel.	42

Water in lubricant.	→	Head gasket packing faulty.	36
	→	Crankcase cracked.	50

Gear oil in lubricant.	→	Hydraulic pump's oil seal broken.	
------------------------	---	-----------------------------------	--

DISASSEMBLY CHART

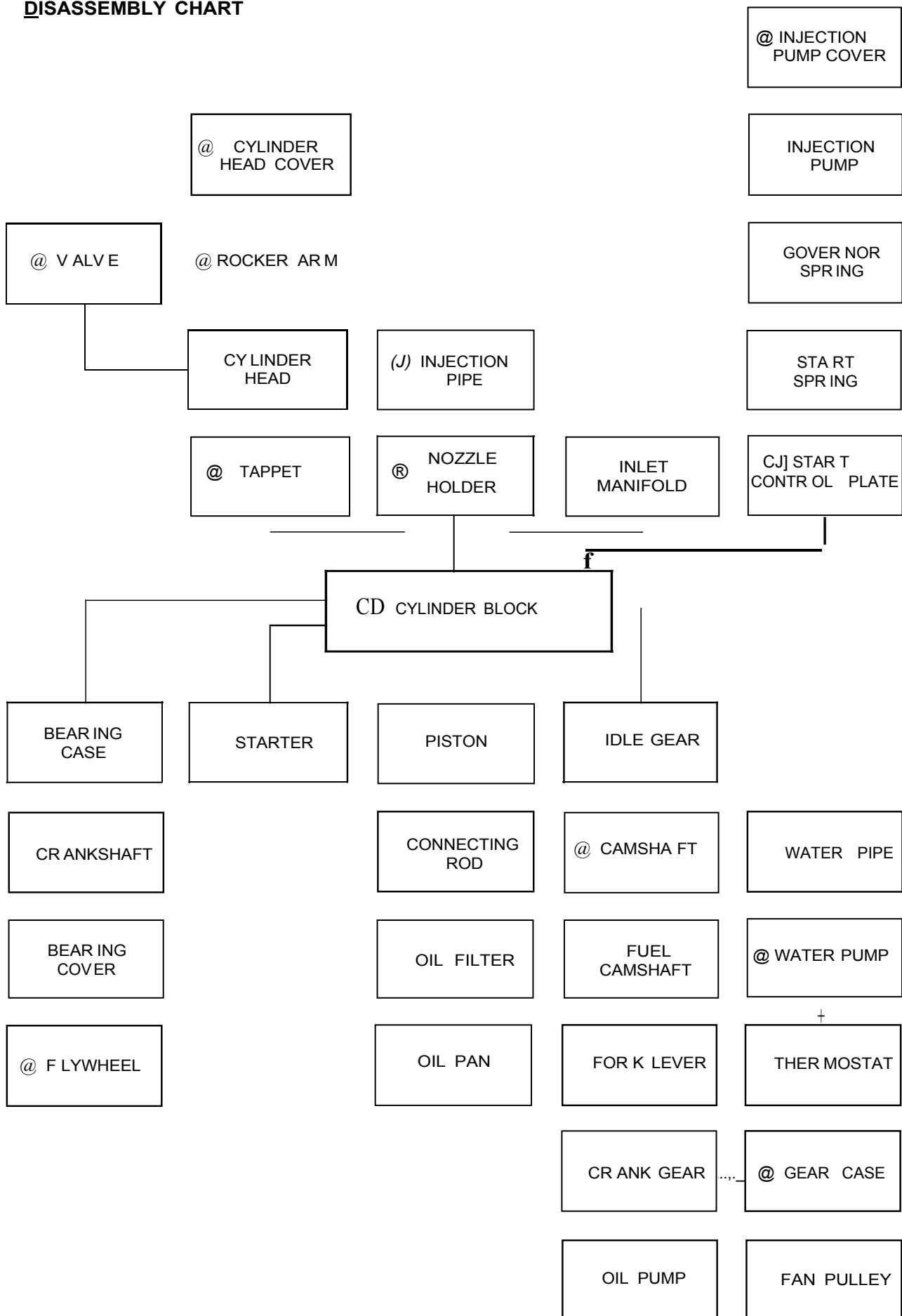

2.DISASSEMBLY AND REASSEMBLY

- ATTENTION: When reassembling, replace all the 0-ring and gaskets by new ones.

CYLINDER HEAD

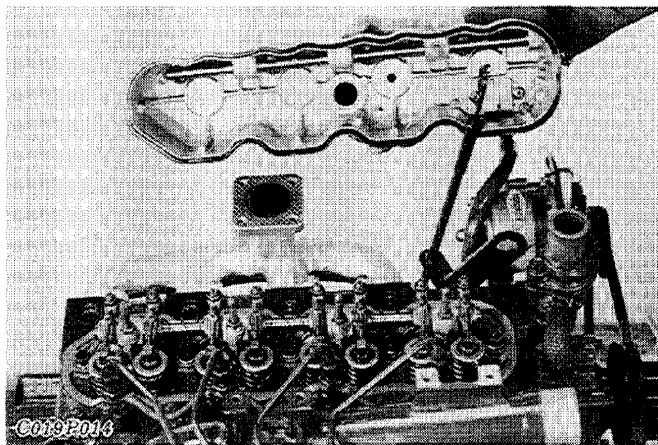

O Removing Cylinder Head Cover

- 1) Remove cap nuts from the cylinder head cover.
- 2) Remove the cylinder head cover and the gasket from the cylinder head.

(Note for reassembling)

- Tighten the cap nuts to 6.9 to 8.8 N•m. (0.7 to 0.9 kgf•m, 5.1 to 6.5 lb.ft.)
- Be careful to refit the breather oil shield in the right direction.

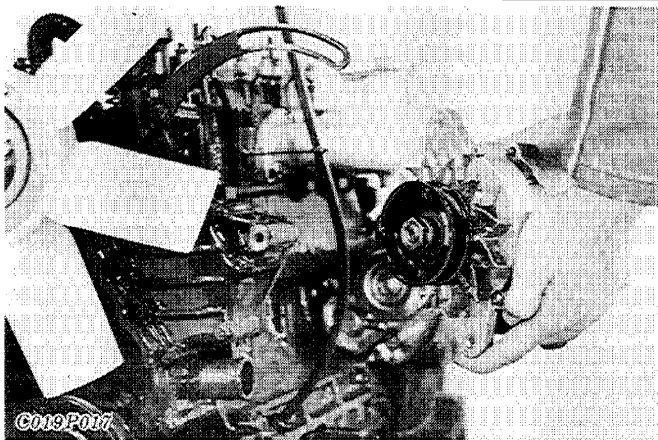

8 Removing Alternator and Fan Belt

- 1) Remove the alternator.
- 2) Detach the fan belt.

(Note for reassembling)

- Fan belt tension
The belt should deflect approx. 7 to 9 mm (0.2756 to 0.3543 in.) when the center of belt is depressed with a finger pressure of 58.8 to 68.6 N. (6 to 7 kgf., 13.2 to 15.4 lb.)

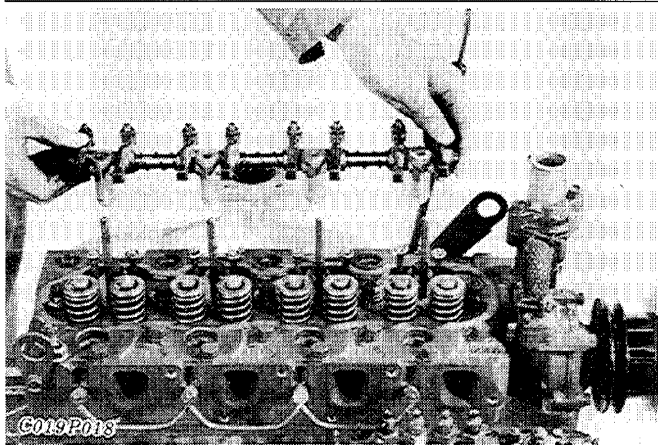

C, Removing Rocker Arm and Push Rod

- 1) Detach the rocker arm.
- 2) Remove the push-rods.

(Note for reassembling)

- Insert the push-rods into the tappets securely.
- Tighten the rocker arm bracket mounting nuts to 23.5 to 27.5 N•m. (2.4 to 2.8 kgf•m, 17.4 to 20.3 lb.ft.)

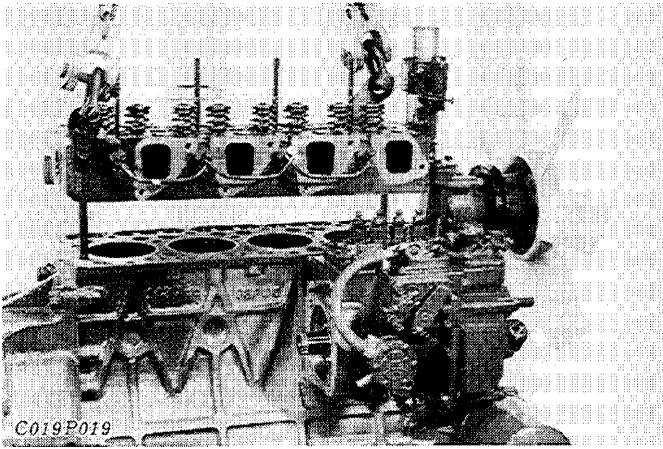

(A) Cylinder head tightening steps

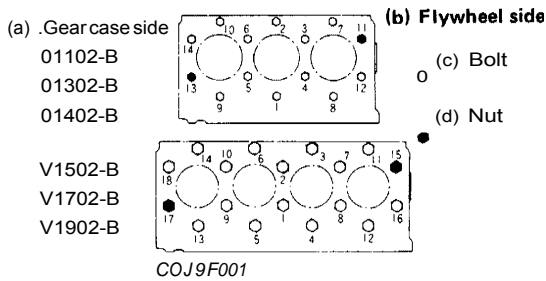

O Removing Cylinder Head

- 1) Detach the water return pipe.
- 2) Detach the cylinder head.
- 3) Remove the gasket and the O-ring.

(Note for reassembling)

- Apply engine oil to each bolt and nut; tighten them equally and in the right order.

(Important)

- When overhauling the engine, replace the gasket with a new one without confusing its front and back. Retighten the nuts after running for 30 minutes.
- Do not forget to refit the O-ring.

Model	Serial Number	Tightening Torque	Remarks
D1102-B	25273	78.5 to 83.4 N·m 8.0 to 8.5 kgf·m 57.8 to 61.5 lb. ft.	Bolt and plainwasher
01302-B	22541		
01402-B	15906		
V1502-B	7433		
V1702-B	1247		
V1902-B	2322	93.2 to 98.1 N·m 9.5 to 10.0 kgf·m 68.7 to 72.3 lb. ft.	Flange bolt
01102-B	25274		
D1302-B	22542		
01402-B	15907		
V1502-B	7434		
V1702-B	1248		
V1902-B	2323		

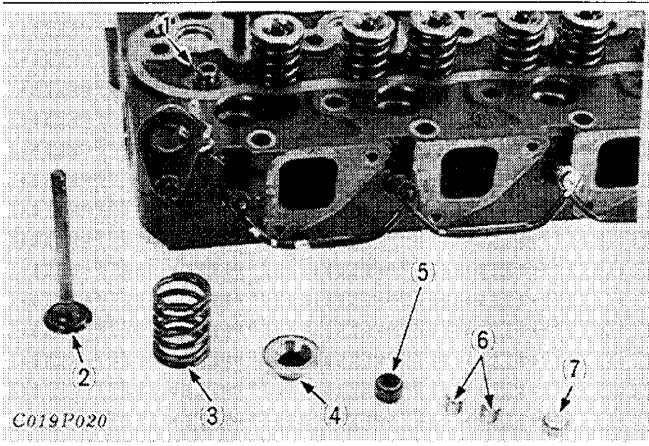

O Disassembling Valve

- 1) Remove the valve cap and the valve spring collet.
- 2) Remove the valve spring retainer and valve spring.
- 3) Remove the valve stem seal and the valve.

(Note for reassembling)

- Replace the valve stem seal, apply a generous amount of engine oil to the new seal and refit it.

- | | |
|---------------------------|-------------------------|
| (1) Valve guide | (5) Valve stem seal |
| (2) Valve | (6) Valve spring collet |
| (3) Valve spring | (7) Valve cap |
| (4) Valve spring retainer | |

O Removing Tappet

- 1) Remove the tappets.

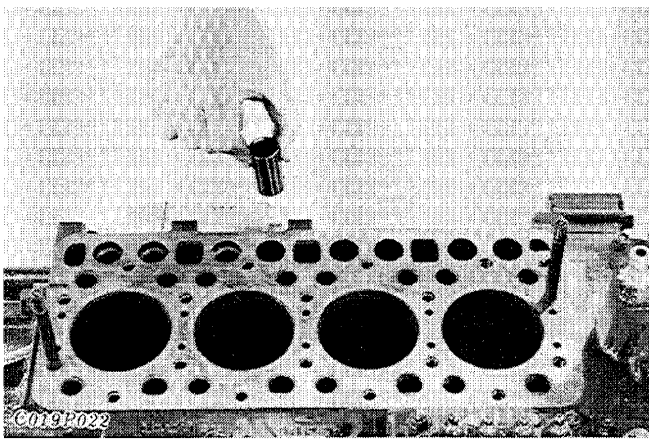

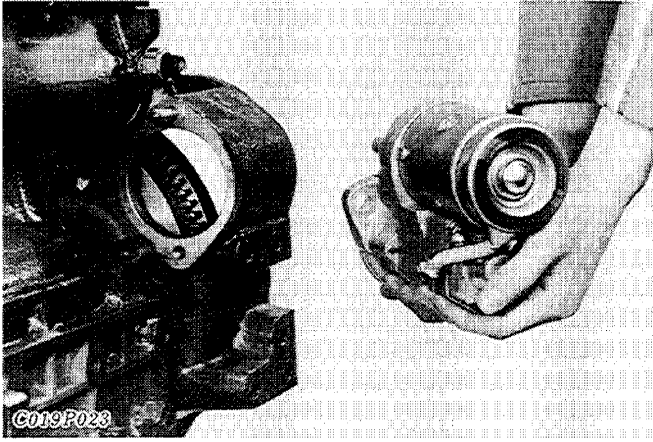

7 Removing Starter

- 1) Remove the starter.

FUEL INJECTION NOZZLE

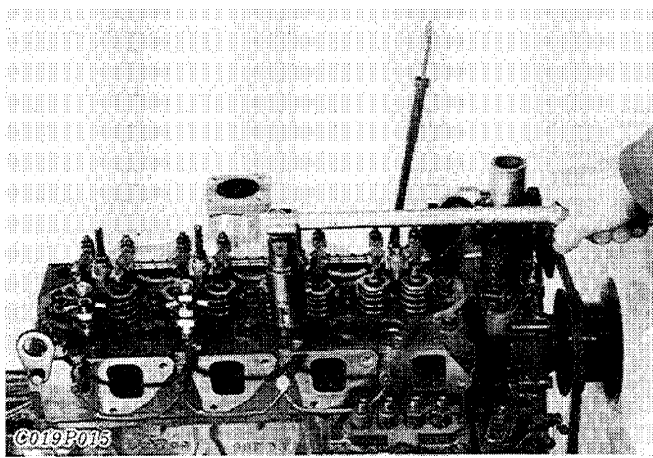

O Removing Nozzle Holder, Injection Pipe, Inlet Manifold

- 1) Disconnect the injection pipe.
- 2) Remove the nozzle holder and the copper gasket.
- 3) Detach the inlet manifold.

(Note for reassembling)

- Take care against the entry of carbon, waste and dirt.
- Replace the copper gasket.
- Tighten the nozzle holder to 29.4 to 49.0 N - m. (3 to 5 kgf , m, 21.7 to 36.2 l b.ft.)

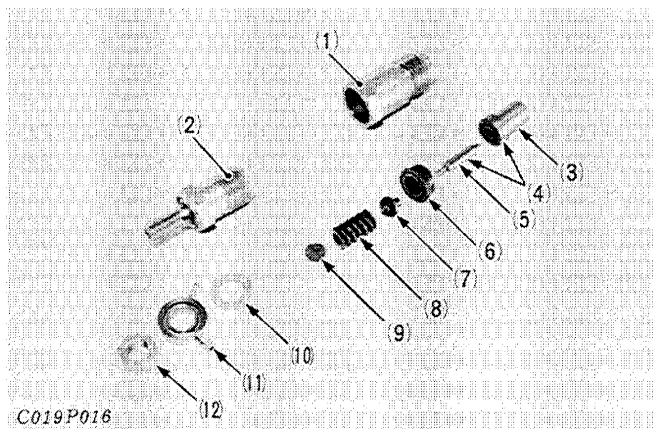

f) Disassembling Nozzle Holder

- 1) Clamp the retaining ring nut in a vise.
- 2) Remove nut, eye joint and plain washer.
- 3) Remove the nozzle holder and take out parts inside.

- When disassembling and assembling the nozzle piece, dip it in clean fuel.

(Important)

- When reassembling do not refit the push rod upside down.
- Tighten the retaining nut to 58.8 to 78.4 N·m. (6 to 8 kgf , m., 43.4 to 57.9 lb.ft.)

Do not tighten it too much, or the needle valve will not slide easily and injection performance will be decreased.

- | | |
|--------------------------|---------------------|
| (1) Retaining nut | (7) Push rod |
| (2) Nozzle holder body | (8) Nozzle spring |
| (3) Nozzle body | (9) Adjust washer |
| (4) Nozzle piece | (10) Plain washer |
| (5) Needle valve | (11) Eye joint |
| (6) Distance piece | (12) Nut |

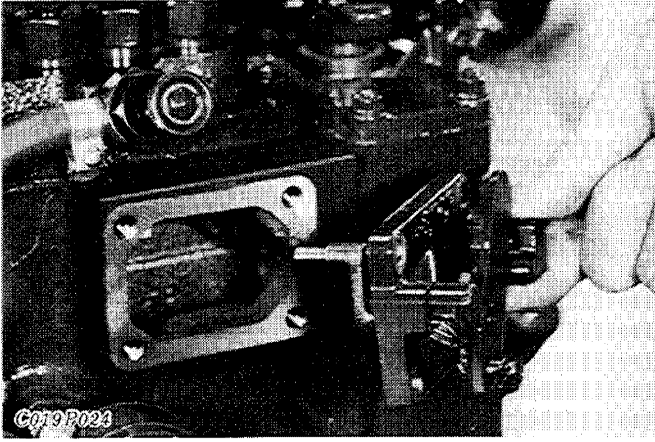

O Removing Injection Pump Cover

- 1) Remove the injection pump cover.

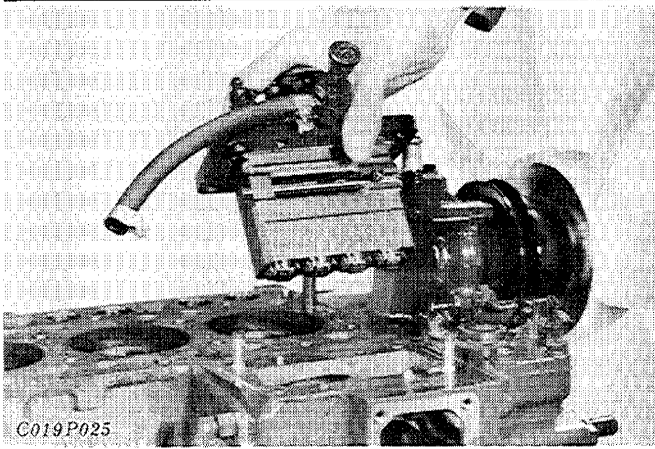

O Removing Injection Pump

- 1) Line up the control rack pin to the slot on the crank case. Remove the injection pump.
- 2) Remove the injection pump shims. Take down the number of the shims for reference.

(Important)

- When reassembling, insert the pump rack pin into the fork lever 1 slot surely.

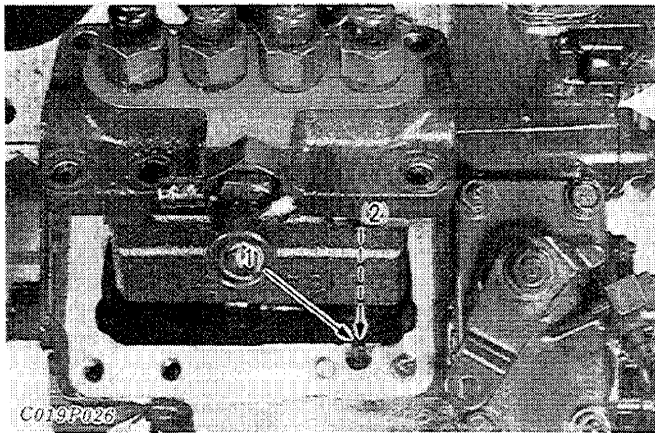

- (1) Slot of fork lever 1
- (2) Insert surely

**GEAR CASE, TIMING GEAR,
CAMSHAFT, OIL PUMP**

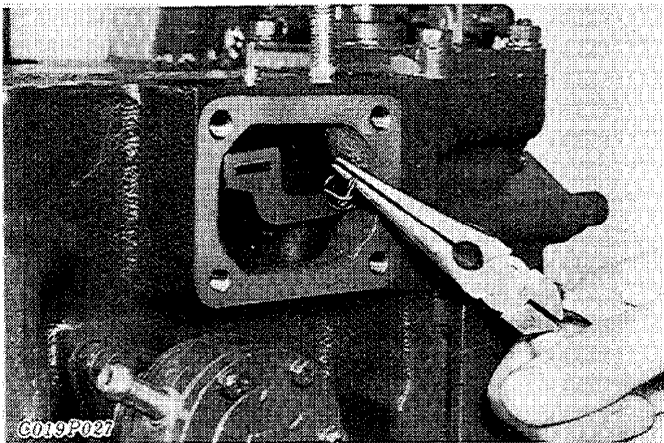

(A) How to remove governor spring

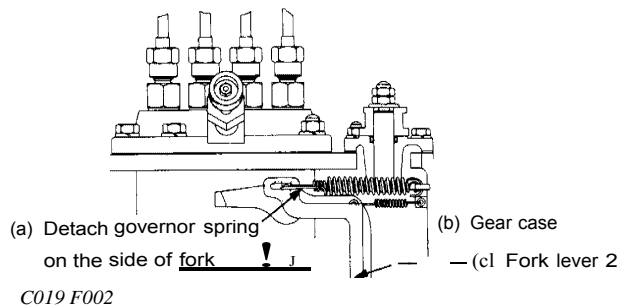

O Detaching Governor Spring

- 1) Detach the governor spring 1 and 2 from the governor fork lever 2.

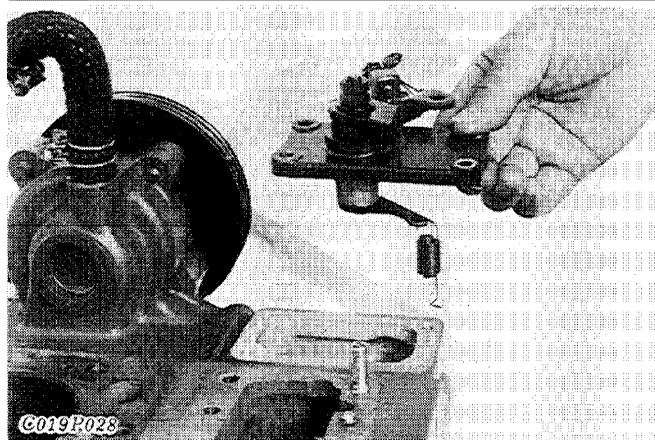

@ Removing Speed Control Plate

- 1) Remove the speed control plate and governor spring.

(Note for reassembling)

- Be careful not to drop the governor spring in the gear case.

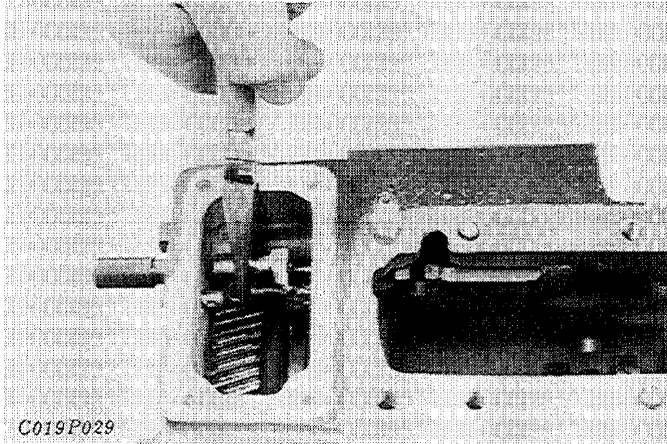

C) Detaching Start Spring

- 1) Remove the start spring from the gear case.

(A) How to remove start spring

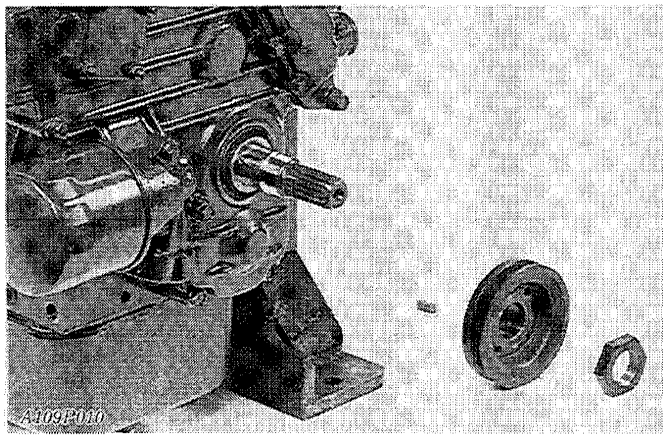
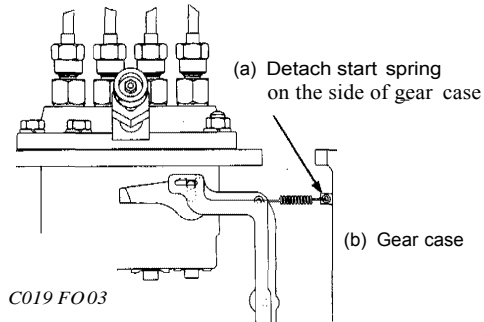

8 Removing Fan Drive Pulley

- 1) Remove the fan drive pulley.
- 2) Remove the key.

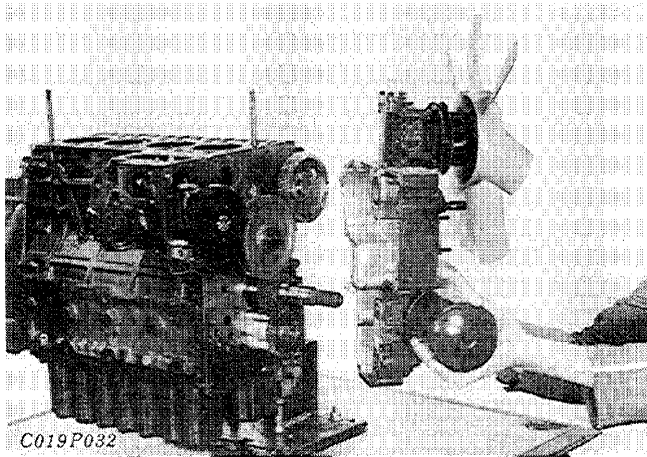

(A) Inside view of gear case assembly

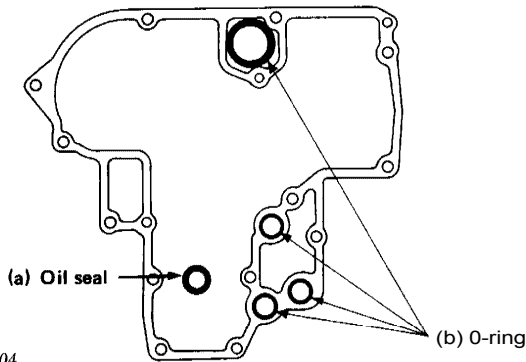

C019F004

CD Removing Gear Case Assembly

- 1) Remove the gear case.
- 2) Remove the O-ring.

(Important)

- When reassembling do not forget to refit the O-ring.
- Apply some grease to the oil seal, and refit it carefully so that its lip will not peel off.

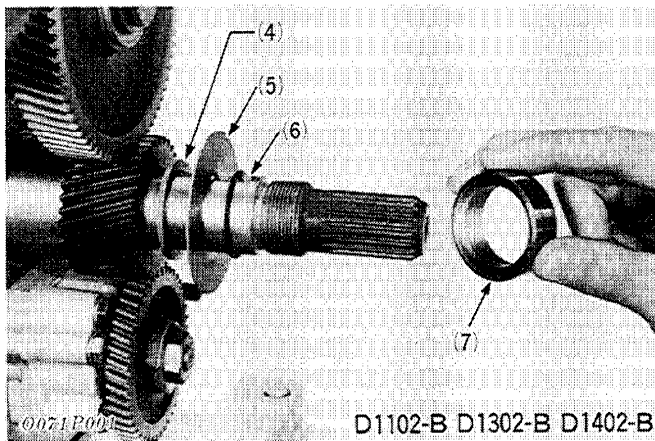
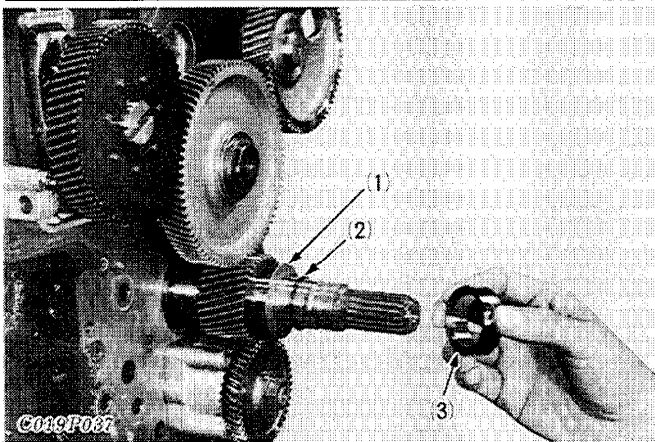

(f) Removing Crankshaft Collar and Oil Slinger

- 1) Remove the crankshaft collar, the O-ring, oil slinger and the crank gear collar (D1102-B, D1302-B, D1402-B only) in that order.

(Note for reassembling)

- Apply oil to the O-ring. Do not confuse assembling order.

- (1) Oil slinger
- (2) O-ring
- (3) Crank shaft collar
- (4) Crank gear collar
- (5) Oil slinger
- (6) O-ring
- (7) Crank shaft collar

D1102-B D1302-B D1402-B

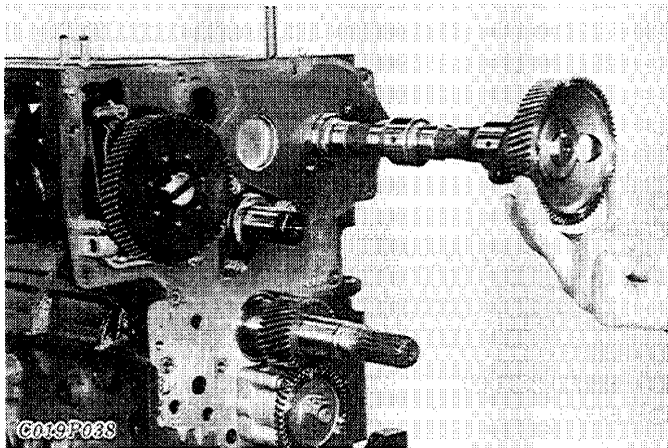

@ Removing Idle Gear and Camshaft

- 1) Remove the external circlip and detach the collar 2, the idle gear and the collar 1 in that order.
- 2) Remove the camshaft stopper bolt.
- 3) Detach the camshaft.

(Important)

- When installing the idle gear, be sure to align the alignment marks on gears.

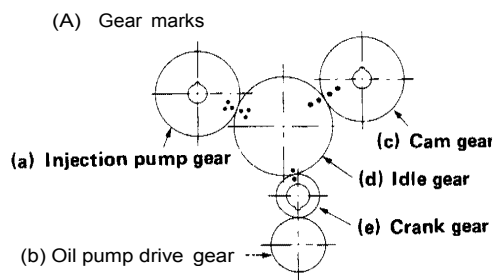

C019F005

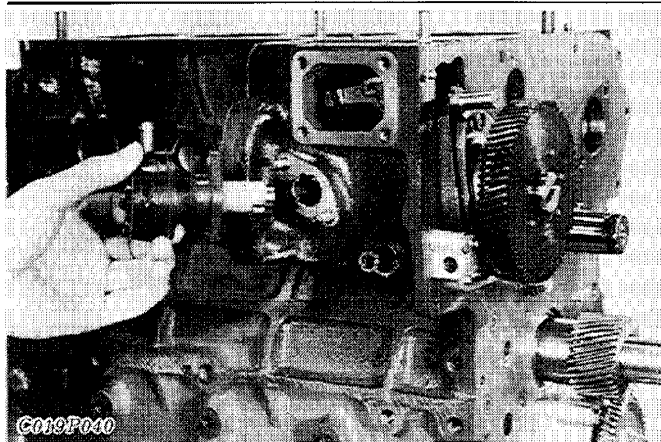

Removing Fuel Feed Pump (V1502-B, V1702-B, V1902-B only)

- 1) Remove the fuel feed pump.

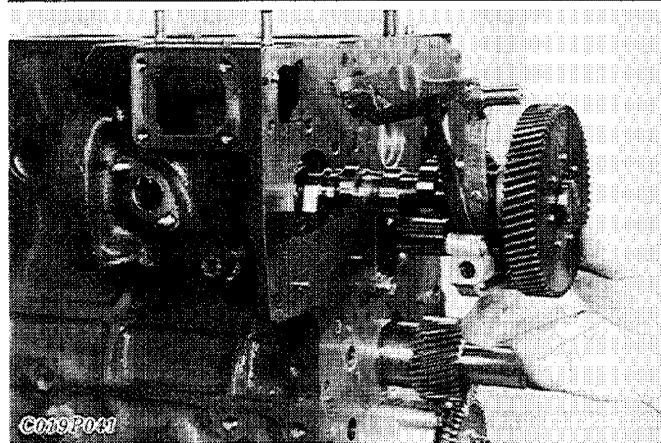

Ci) Removing Fuel Camshaft and Fork Lever Holder

- 1) Detach the fuel camshaft cover.
- 2) Remove the external circlip and the collar (D1402-B, V1502-B, V1702-B, V1902-B only).
- 3) Remove the three fork lever holder set bolts.
- 4) Remove the fuel camshaft and the fork lever shaft at the same time.

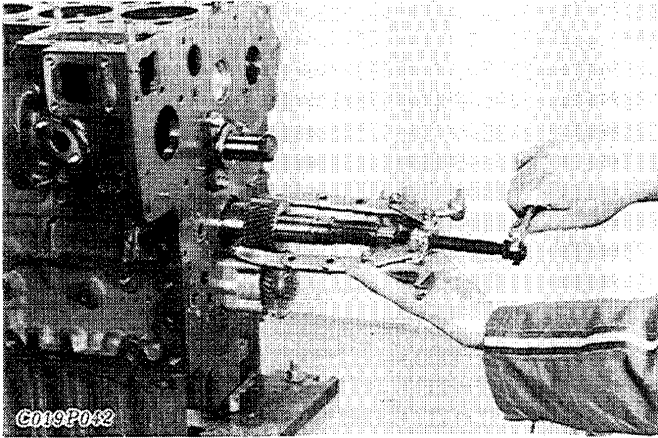

CD) Removing Crank Gear

- 1) Detach the crank gear with a puller.

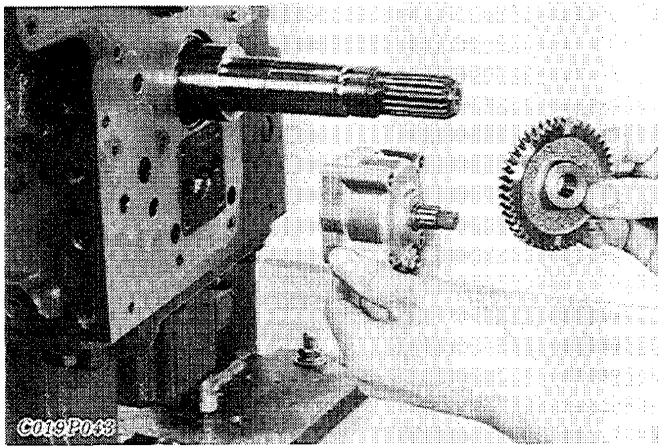

— Removing Oil Pump

- 1) Detach the pump drive gear.
- 2) Detach the oil pump.

THERMOSTAT, WATER PUMP

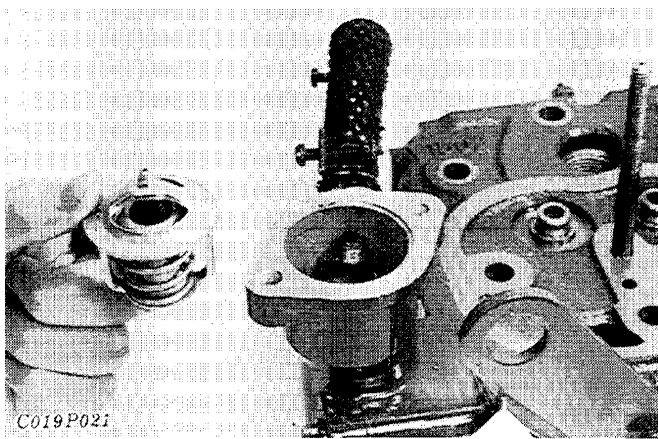

0 Removing Thermostat

- 1) Remove the thermostat cover.
- 2) Remove the thermostat.

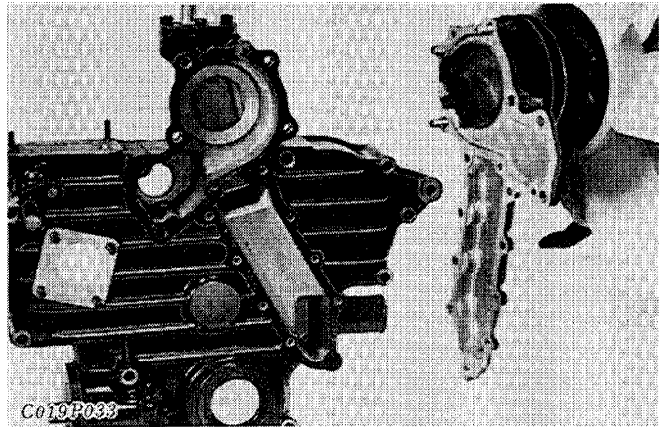

@ Removing Water Pump

- 1) Detach the water pump from the gear case.

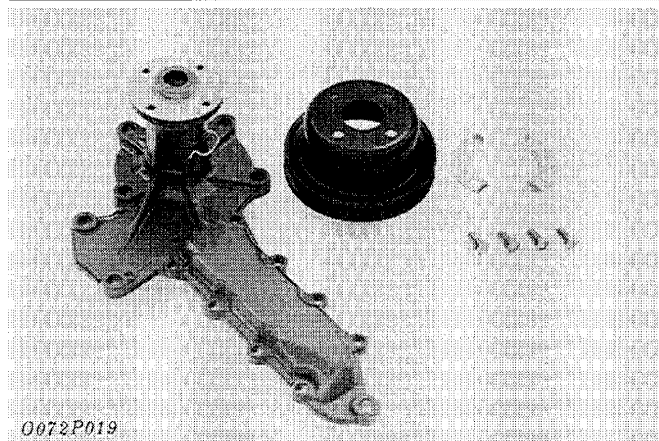

Disassembling the Water Pump (1) Removing Fan Pulley

- 1) Straighten the lock washer.
- 2) Remove the fan pulley.

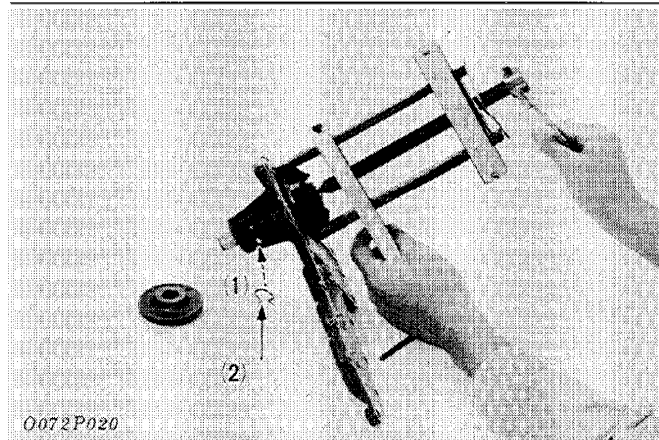

(2) Removing Water Pump Shaft and Bearing Assembly

- 1) Remove the snap pin. (Snap pin type only)
- 2) Remove the water pump shaft flange.
- 3) Remove the impeller.
- 4) Drive out the water pump shaft and bearing assembly from the impeller side of the water pump.

(Important)

- When reassembling, replace the water pump shaft and bearing assembly by new one.

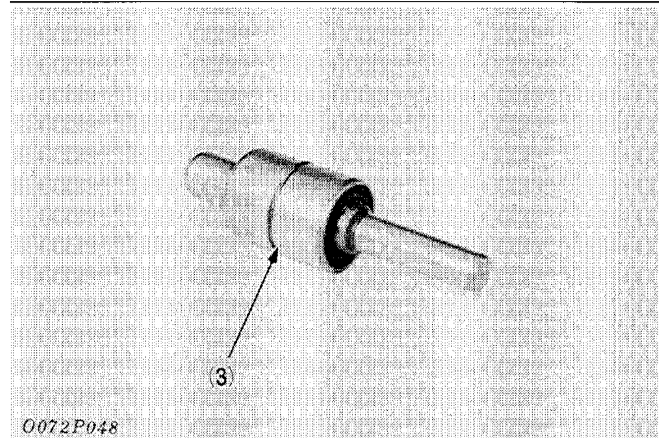

- (1) Insert surely (Snap pin type only)
- (2) Snap pin (Special) (Snap pin type only)
- (3) Water pump shaft and bearing assembly

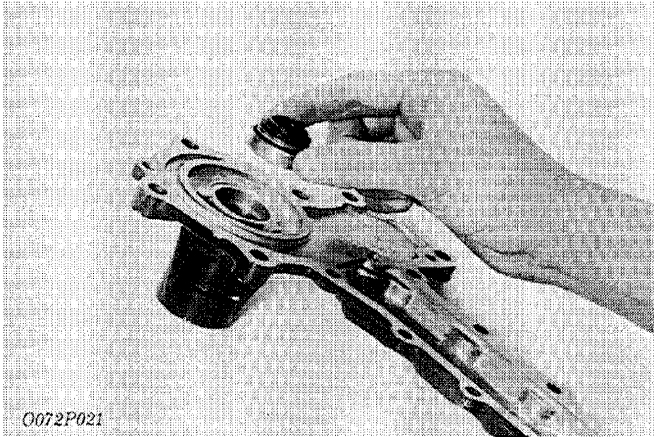

(3) Removing Seal Set

- 1) Remove the sealset.

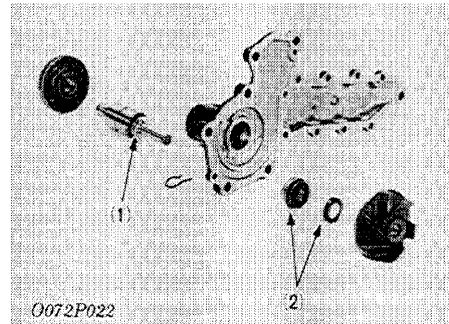

- (1) Slinger
- (2) Seal set

PISTON, CRANKSHAFT

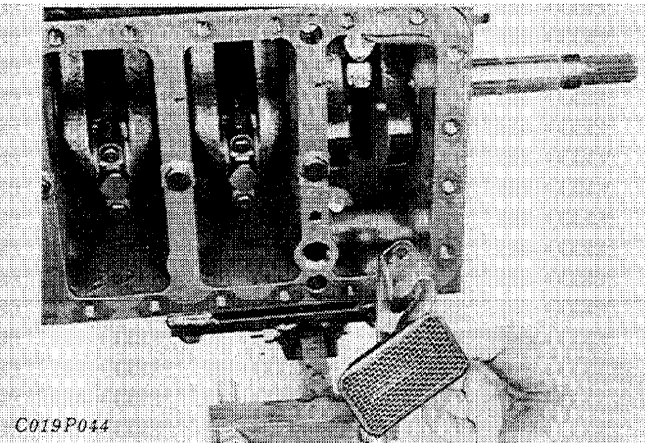

O Removing Oil Pan, Oil Filter 1

- 1) Detach the oil pan.
- 2) Remove the oil filter 1. Be careful of the O-ring.

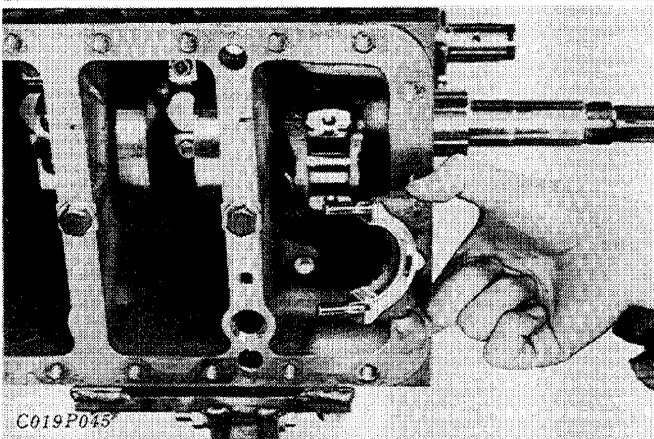

f) Removing Connecting Rod

- 1) Detach the connecting rod bolt.
- 2) Remove the cap of the large end of the connecting rod.

(Important)

- When reassembling, apply engine oil to the connecting rod bolts.

Tightening torque	Non Flange Bolt (3)	36.3 to 41.2 N-m 3.7 to 4.2 kgf-m 26.6 to 30.4 ft.lbs
	Flange Bolt (4)	44.1 to 49.0 N-m 4.5 to 5.0 kgf-m 32.5 to 36.2 ft.lbs

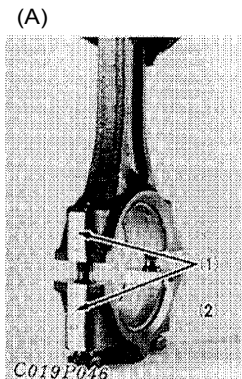

- (A) Reassembling of connecting rod
- (1) Align the marks with each other.
 - (2) Face the marks toward the injection pump.

(B) Connecting rod bolt

(3) Non flange_bolt (4) Flange bolt



A069F001

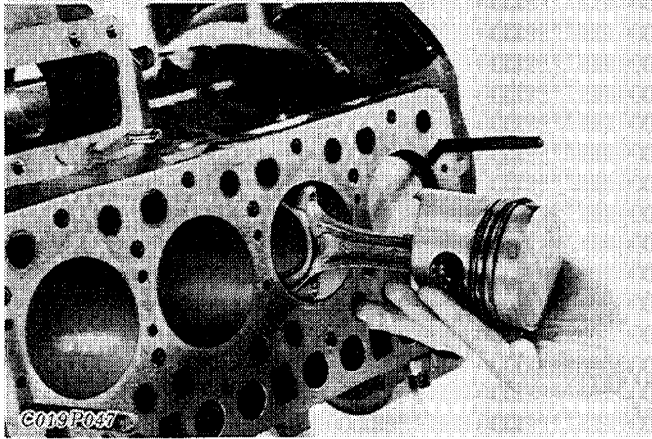

(A) Markings on the piston head

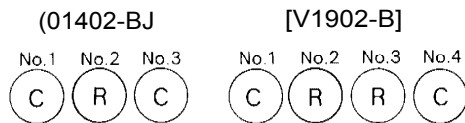

A069F002

@) Removing Piston

- 1) Drive out the piston to the cylinder head side with a hammer grip.
- 2) After driving the piston out, attach a tag to each piston to indicate its number.

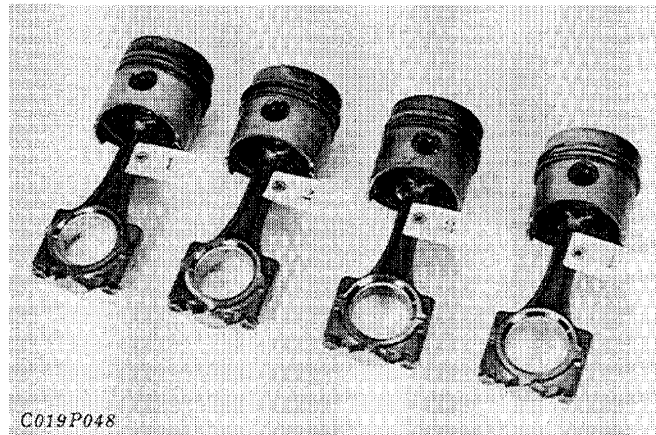

C019P048

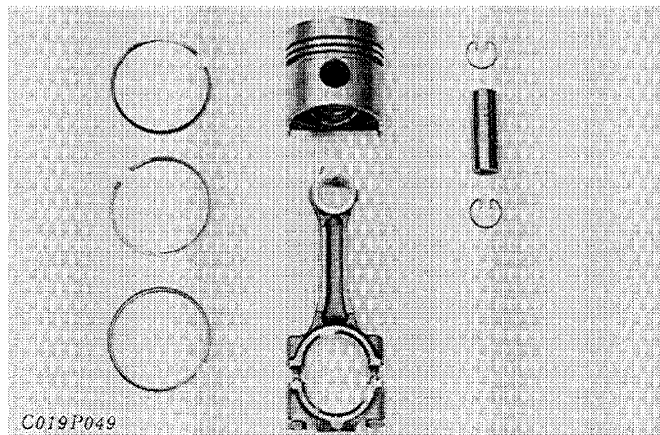

C019P049

(A) Reassembling of piston, piston rings and connecting rod

- (a) Mark before disassembling
When installing a piston, face this mark toward the alignment marks.

:TI (b) Plated Keystoning
=:C:i (c) Discontinuous undercut ring

(g) Taper and inside cut ring [V1702-B] only
Engine serial number : 37196 and beyond

(d) Coil expander ring

(e) Camshaft

(f) Alignment marks

When installing a connecting rod face the alignment marks toward the injection pump.

co19FO0/i

4 Removing Piston Ring

- 1) Remove the piston rings.
- 2) Remove the piston pin. Mark the piston head so that the piston will be reassembled in the right direction. Also, to avoid wrong reassembling, write down the number of the piston and the connecting rod as a pair.

(Note for reassembl i ng)

- When reassembl i ng, the connecti ng rod to the piston, heat the piston well and tap in the piston pin. Make sure that the piston is reassem bled with the right connecti ng rod. Face the mark on the piston head toward the connecti ng rod.
- When install i ng a piston ring onto the piston, face the mark (manufactu rer's name or "TOP") toward the piston head.
- When install i ng the coil expander i n the ri ng, place the expander joint on the opposite side (3.14 rad.(180°)) of the ring gap.
- Place the piston ri ng so that there are gaps every 1.57 rad. (90°) with no gap facing the piston pin in the cyl i nder.

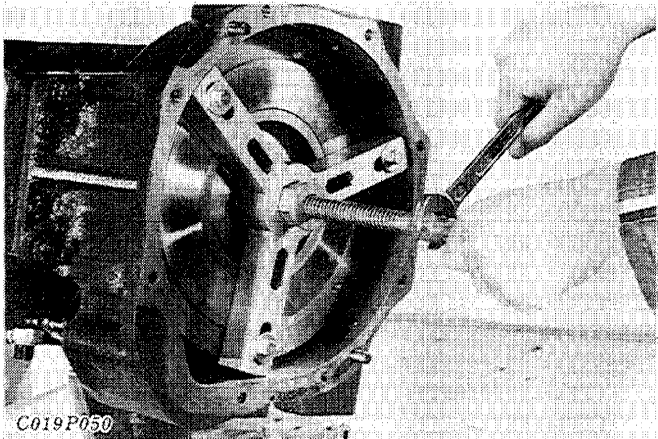

C019P050

(A) Reassembling of flywheel washer

(a) Mark

Install the flywheel washer so that the mark is opposite the flywheel surface.

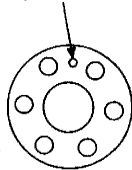

C019F007

(b) Clearance

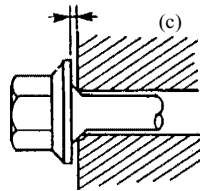

(c) Flywheel

8 Removing Flywheel

- 1) Detach the flywheel bolts.
- 2) Remove the flywheel.

(Important)

- When reassembling, tighten the flywheel bolts to 98.1 to 107.9 N·m (10 to 11 kgf·m, 72.3 to 79.6 lb·ft.).
- To use a flanged bolt on the conventional flywheel, rework the chamfered portion of the bolt hole. (Chamfer: C0.9 to C1.3)

If the flanged bolt is used without reworking, a clearance will develop as shown below, resulting in an insufficient tightening torque.

Model	Serial Number	Remark
D1102-B	38692 -	Flange bolt (without washer)
D1302-B	33434 -	
D1402-B	44173 ,,,,,	
V1502-B	21064 ,,,,,	
V1702-B	44933 -	
V1902-B	67309 ,,,,,	

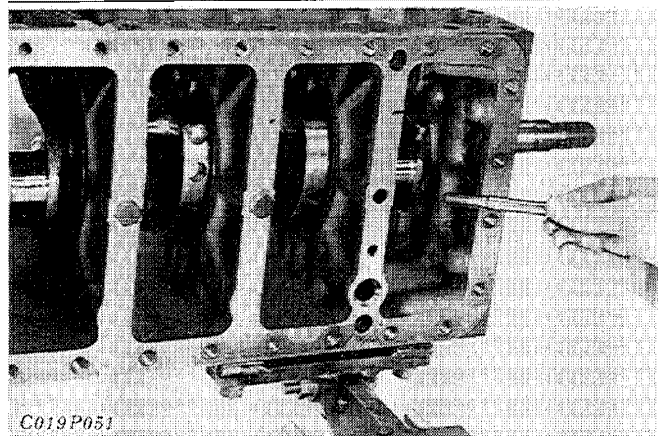

C019P051

8 Removing Bearing Case Bolt 2

- 1) Detach the bearing case bolt 2.

(Note for reassembling)

- Line up the hole on the bearing case with that on the crankcase, then tighten bearing case bolts 2.

Model	Serial Number	Tightening Torque	Remarks
D1102-B	38579	63.7 to 68.6 N·m 6.5 to 7.0 kgf·m 47.0 to 50.6 lb·ft.	Bolt and washer
D1302-B	33413		
01402-B	43733		
V1502-B	20822		
V1702-B	43698		
V1902-B	65775	68.6 to 73.5 N·m 7.0 to 7.5 kgf·m 50.6 to 54.2 lb·ft.	Flange bolt
01102-B	38580 ,,,,,		
D1302-B	33414		
D1402-B	43734 ,,,,,		
V1502-B	20823 ,,,,,		
V1702-B	43699 ,,,,,		
V1902-B	65776 =		

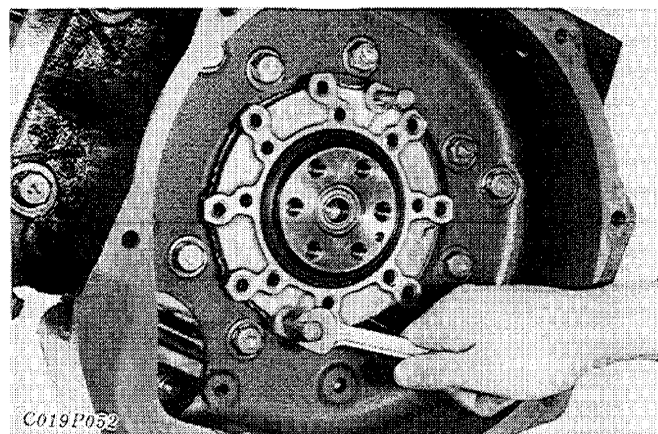

C019P052

@ Removing Bearing Cover

- 1) Remove the bolts.
- 2) Drive two MS bolts into the bearing cover and then pull the cover out.

(Note for reassembling)

- Grease the oil seal, be careful not to peel the lip off.

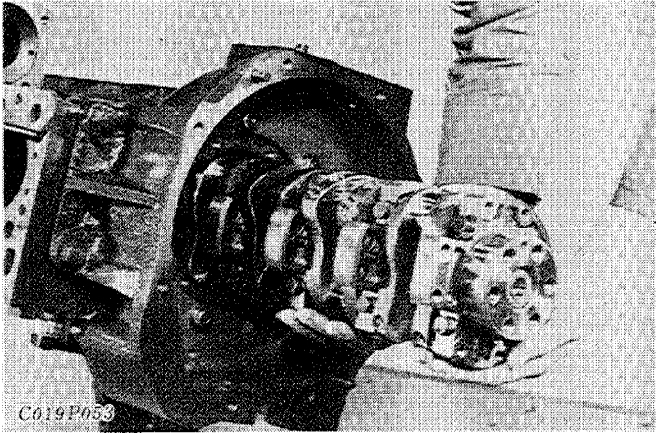

8 Removing Crankshaft

- 1) Tap the crankshaft until it comes out of the flywheel side; be careful not to scratch the crankshaft bearing.

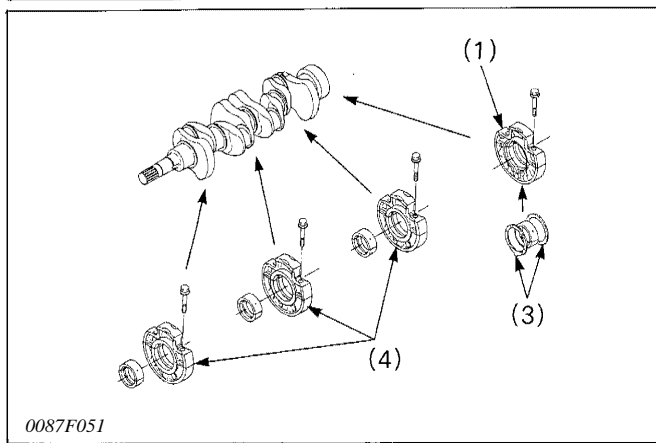

Ci) Removing Bearing Case

- 1) Remove the bearing case screws 1, then the main bearing case assembly 1 (1), being careful with the side metal (3) and crankshaft bearing 2.
- 2) Remove the main bearing case assemblies 2,3 and 4 (4) as above.

(Note for reassembling)

- Clean the oil passage in the main bearing case.
- Apply clean engine oil on the crankshaft bearing 2 and side metals.
- Since the diameters of main bearing cases vary, install them in order of markings (1,2 and 3) from the gear case side.
- When installing the main bearing case assemblies 2,3 and 4, face the mark (- 11?) to the gear case side.
- Be sure to install the side metal with its oil groove (2) facing outward.

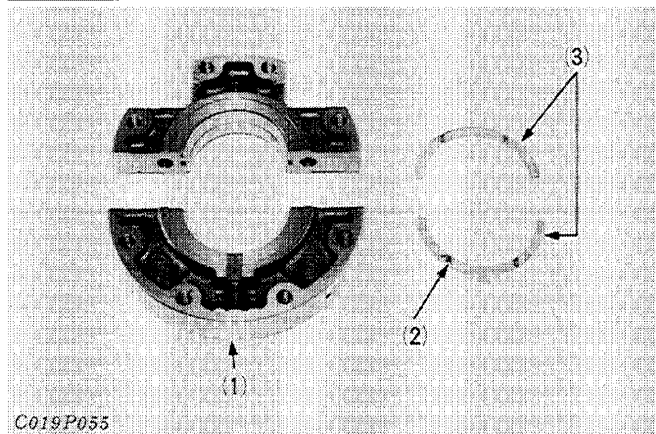

Model	Serial Number	Tightening Torque	Remarks
D1102-B	-38538	29.4 to 34.3 N m 3.0 to 3.5 kgf.m 21.7 to 25.3 lb.ft	Bolt and washer
D1302-B	-33385		
D1402-B	-43007		
V1502-B	,20589		
V1702-B	-42863		
V1902-B	-62871	36.3 to 41.2 N-m 3.7 to 4.2 kgf.m 26.8 to 30.4 lb.ft.	Flange bolt
D1102-B	38539-		
D1302-B	33386-		
D1402-B	43008-		
V1502-B	20590-		
V1702-B	42864--		
V1902-B	62872-		

- (1) Main bearing case assembly 1
- (2) Oil groove
- (3) Side metal
- (4) Main bearing case assembly 2,3 and 4

3.SERVICING

CYLINDER HEAD

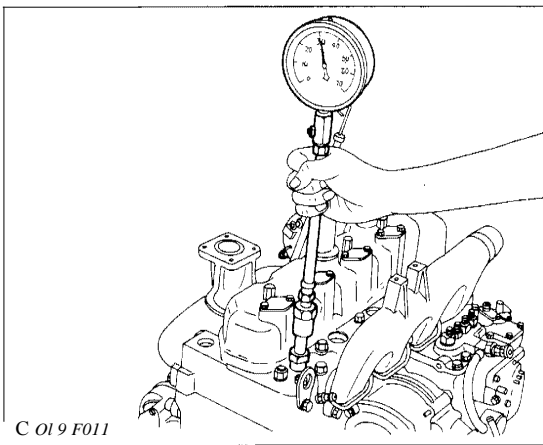

C 019 F011

0 Checking Compression Pressure

- 1) Warm up the engine.
- 2) Remove the air cleaner and the muffler.
- 3) Remove the nozzle holders from all the cylinders.
- 4) Attach a compression tester to the cylinder to be measured.
- 5) Run the engine with the starter at 200 to 300 min-1{rpm} and read constant maximum on the tester. Execute the test at least twice. (Run the engine for 5 to 10 seconds for each test.)

- For the test, use a fully charged battery and the specified valve clearance.
- If the compression pressure is below the given allowable limit, pour a small amount of oil through the nozzle holder hole and test again.
- Judgment.
 - 1) If the pressure recovers to standard level, inadequate pressure may be caused by wear or adhesion of the piston rings. Check the related points.
 - 2) If the pressure does not recover, cylinder head or valve problems may be the cause. Check the related points.
 - 3) If the compression differs more than 10% among the cylinders, trace the cause of pressure variation and take corrective measures.

Reference value	
Reference compression pressure	2.9 to 3.2 MPa 30 to 33 kgf/cm ² 427 to 469 lb./sq. in.
Compression pressure allowable limit should be more than 75% of reference compression pressure	2.2 to 4.2 MPa 23 to 25 kgf/cm ² 320 to 352 lb./sq. in.
Difference in compression pressure among cylinders should be less than 10%.	

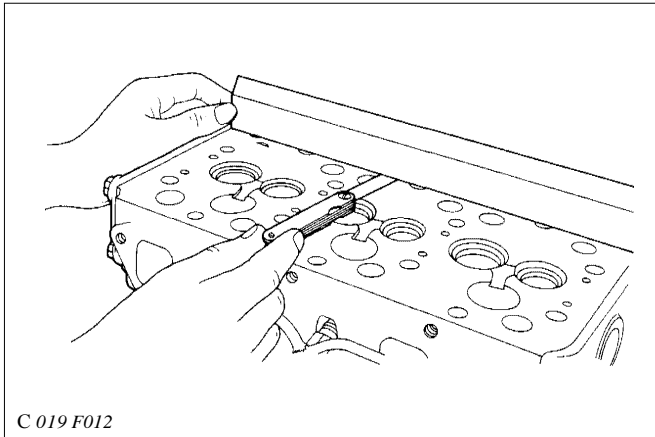

C 019 F012

(A) How to check cylinder head surface

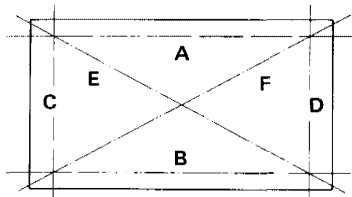

C 019 F013

fj Checking Distortion of Cylinder Head Surface

- 1) Clean the surface of the cylinder head.
- 2) Put a straight edge on the four sides and diagonal lines of the cylinder head to check the straightness of the surface, as shown at the left.
- 3) Insert a feeler gauge between the straight edge and the cylinder head surface.
- 4) The maximum thickness inserted is the amount of distortion.
- 5) If the measurement exceeds the allowable limit, correct with a surface grinder.

(Note)

- Do not place a straight edge on the combustion chamber.

Reference value	
Allowable limit	0.05 mm (0.0020 in.) / 100 mm (3.9370 in.) of cylinder head surface length.

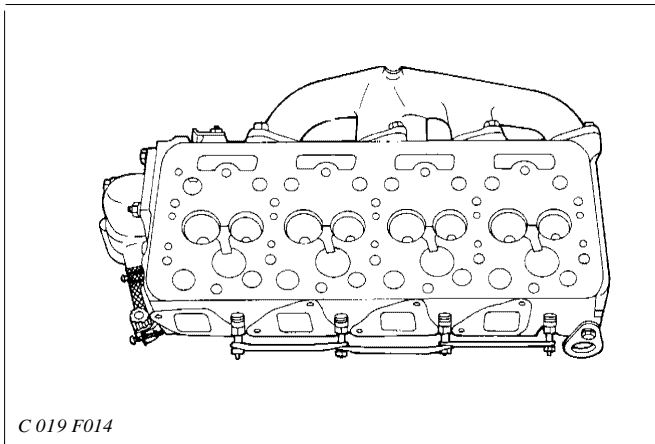

C 019 F014

@ Checking Flaw of Cylinder Head Surface

- 1) Clean the surface of the cylinder head.
- 2) Spray the cylinder head surface with the red permeative liquid.
- 3) Wash away the red permeative liquid on the cylinder head surface with the detergent.
- 4) Spray the cylinder head surface with the developer. If flawing, it can be identified as red marks.

Reference value	Should be no flaw.

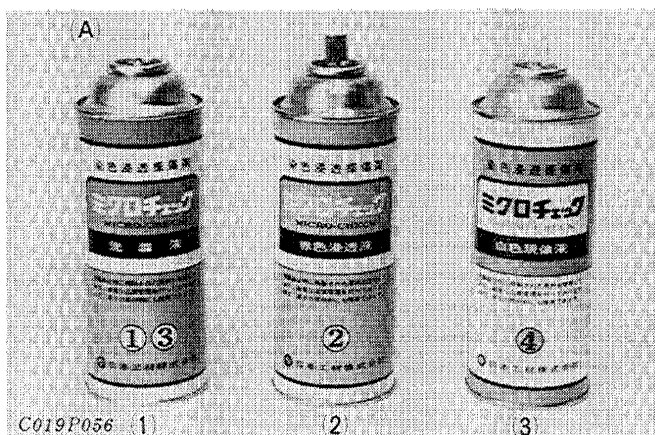

C019P056 1)

2)

3)

(A) Air spray red check

- (1) Detergent
- (2) Red permeative liquid
- (3) White developer

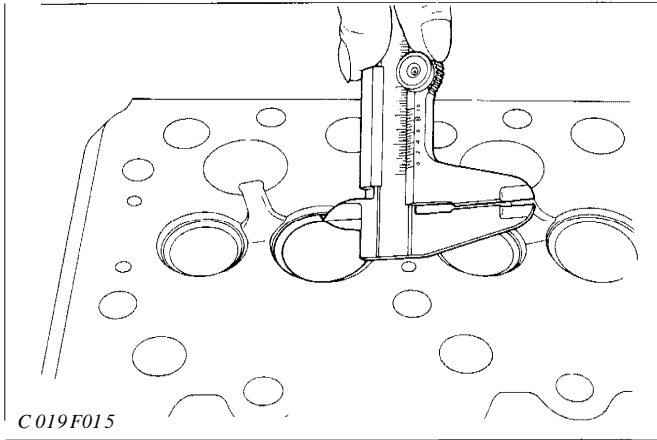

C019F015

(A) How to repair the valve seat

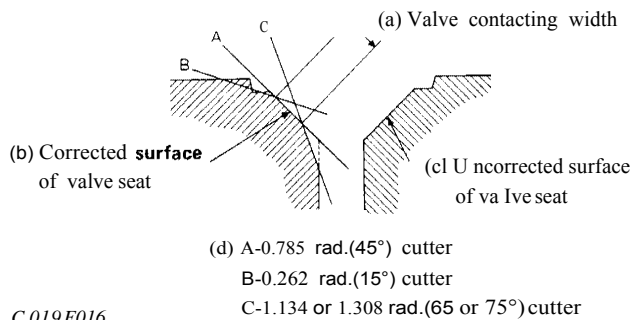

C019F016

O Checking and Refining Valve Seat Width

- 1) Clean the valve seat surface.
- 2) Measure the width of the seat using a set of vernier calipers.
- 3) Apply red lead on the valve to check if the seat is scratched or not.

• To correct the dimensions of the valve seat using a valve seat cutter, follow the steps.

- 1) Use a cutter suitable for the valve guide and the valve seat. (0.785 rad.(45°), ϕ 8mm (0.315 in.))
- 2) Grind off the front surface of the valve seat by 0.262 rad. (15°), since the seat surface becomes wider than before.
- 3) Grind off the rear surface of the seat by using 1.134 or 1.308 rad. (65 or 75°) cutter to finish the seat 2.1 mm (0.0827 in.) wide.
- 4) Reface the valve.

Reference value	2.1 mm 0.0827 in.
-----------------	----------------------

(+) Checking Valve Recessing

- 1) Clean the face of the valve.
- 2) Measure the sinking with a depth gauge.
- 3) If the measurement exceeds the allowable limit, replace.

Reference value	1.1 to 1.3 mm 0.0433 to 0.0512 in.
Allowable limit	1.6 mm 0.0630 in.

C019F017

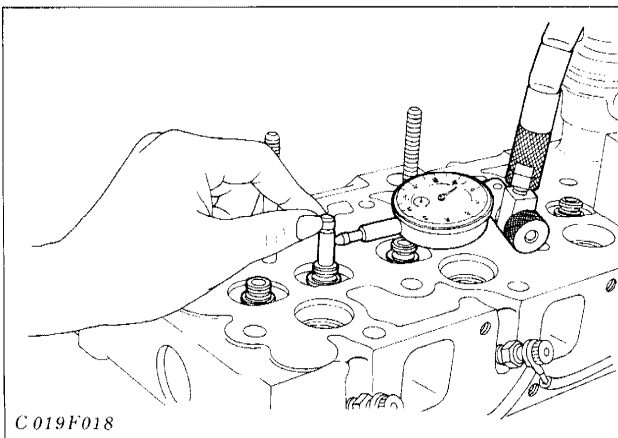

C019F018

(i) Checking Stem Guide Clearance

- 1) Remove carbon from the valve guide.
- 2) After making sure that the valve stem is straight, insert the valve into the valve guide.
- 3) Measure the stem guide clearance with a dial gauge.
- 4) If the measurement exceeds the allowable limit, replace the stem guide and the valve.

(Note for replacing)

• Inlet and exhaust valve guide resemble each other in shape. To install them, be sure that they are on the proper side.

Reference value	0.04 to 0.07 mm 0.0016 to 0.0028 in.
Allowable limit	0.10 mm 0.0039 in.

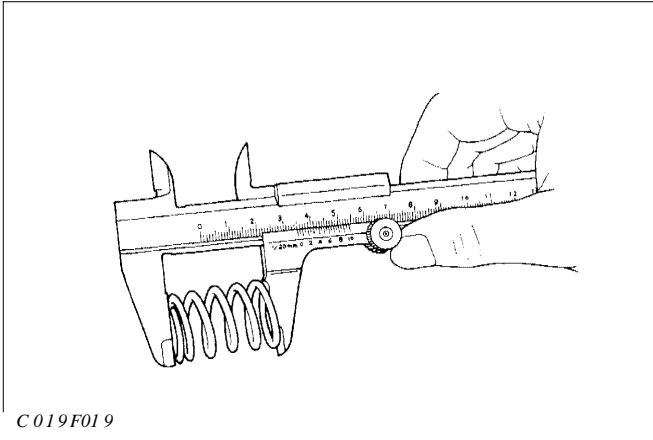

@ Checking Free Length of Valve Spring

- 1) Measure the spring with a set of vernier calipers.
- 2) If the measurement exceeds the allowable limit, replace the valve spring.

Reference value	41.7 to 42.2 mm 1.6417 to 1.6614
Allowable limit	41.2 mm 1.6220 in.

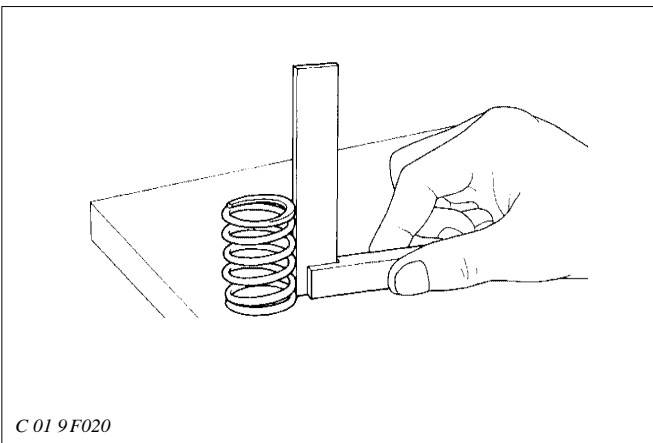

t1) Checking Valve Spring Squareness

- 1) Put the spring on a surface plate, place a square on the side of the spring, and check to see if the entire side is in contact with the square.
- 2) Rotate the spring and measure the maximum B.
- 3) The flat surface at the end of the spring coil must exceed two-thirds of the full circumference.
- 4) Check all the surface of the spring for scratches.
- 5) If the measurement exceeds the allowable limit, replace the valve spring.

	Reference value
Allowable limit	1.0 mm 0.0394 in.

(A) How to measure squareness of the valve spring

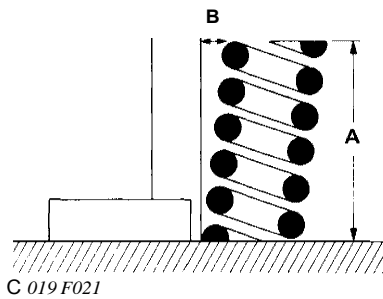

fj) Checking Valve Spring Tension

- 1) Place the spring on a tester, compress it to the level to which the spring is actually compressed in the engine.
- 2) Read the compression load on the gauge.
- 3) If the measurement exceeds the allowable limit, replace the valve spring.

Reference value	117.7 N./35.15 mm 12 kgf./35.15 mm 26.5 lb./1.3839 in.
Allowable limit	100.0 N./35.15 mm 10.2 kgf./35.15 mm 22.5 lb./1.3839 in.

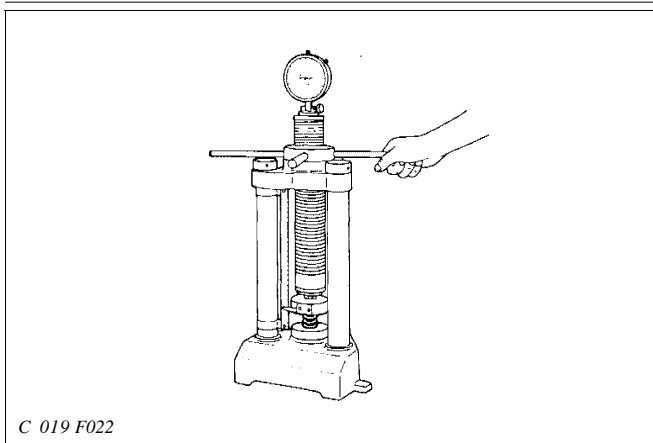

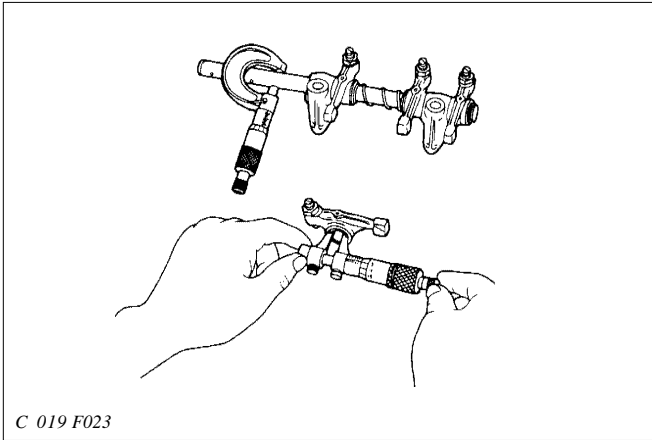

C 019 F023

Cli) -m Checking Oil Clearance between Rocker Arm Shaft and Bushing

- 1) Measure the inside diameter of the rocker arm bushing.
- 2) Measure the rocker arm shaft diameter. Calculate the clearance value.
- 3) If the clearance exceeds the allowable limit, replace.

Reference value	0.018 to 0.070 mm 0.0007 to 0.0028 in.
Allowable limit	0.15 mm 0.0059 in.

Rocker arm shaft diameter	13.973 to 13.984 mm 0.5501 to 0.5506 in.
Bushing inside diameter	14.002 to 14.043mm 0.5513 to 0.5529 in.

Cli)-(11) Checking Oil Clearance between Rocker Arm Shaft and Rocker Arm (Bushless Type)

- 1) Measure the inside diameter of the rocker arm.
- 2) Measure the rocker arm shaft diameter. Calculate the clearance value.
- 3) If the measurement exceeds the allowable limit, replace.

Reference value	0.018 to 0.070 mm 0.0007 to 0.0028 in.
Allowable limit	0.15 mm 0.0059 in.

Rocker arm shaft diameter	13.973 to 13.984 mm 0.5501 to 0.5506 in.
Rocker arm inside diameter	14.002 to 14.043mm 0.5513 to 0.5529 in.

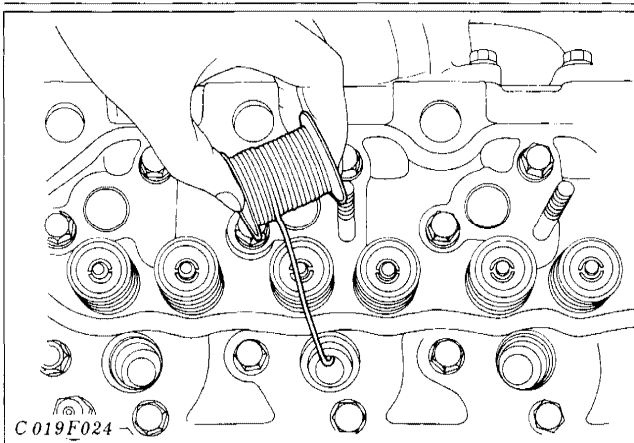

C 019 F024

41, Checking Top Clearance

- 1) Detach the nozzle holder.
- 2) Lower the piston in the cylinder to be measured.
- 3) Insert a high-quality fuse from the nozzle holder hole. Be careful not to let the fuse touch the valve surface.
- 4) Rotate the engine with your hand.
- 5) Take the fuse out carefully.
- 6) Measure with a set of vernier calipers where the fuse was crushed.
- 7) If the measurement is not within the reference value, adjust by inserting a shim between the cylinder head and gasket.

Reference value	0.7 to 0.9 mm 0.0276 to 0.0354 in.
-----------------	---------------------------------------

Thickness of gasket when new	1.30 to 1.60 mm 0.0512 to 0.0630 in.
------------------------------	---

Thickness of gasket shim	0.20 mm 0.0078 in.
--------------------------	-----------------------

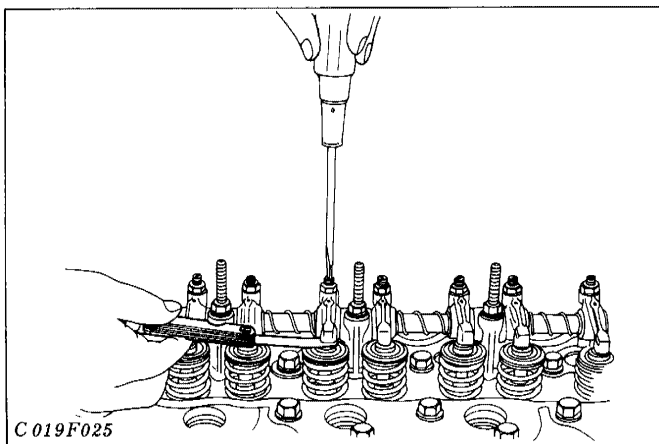

(A) Valve clearance

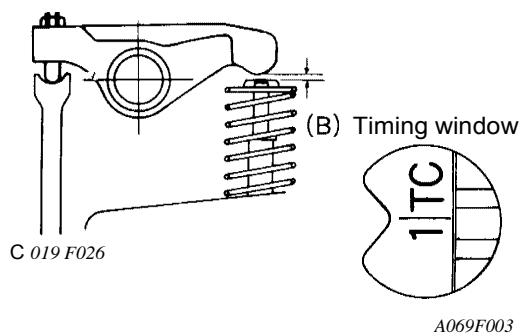

8 Adjusting Valve Clearance

- 1) Remove the cylinder head cover.
- 2) Turn the flywheel and align the 1TC or 1- 4TC mark with the projection in the window on the flywheel housing to position the 1st cylinder at the top dead center during compression.
- 3) Measure the clearance at the valves marked with \circ in the table below with a feeler gauge.
- 4) If the clearance is not within the factory specifications, turn the adjusting screw to adjust.
- 5) Turn the flywheel just one turn to position the 1st cylinder at the top dead center during overlap.
- 6) Measure the clearance at the valves marked with \bullet in the table below with a feeler gauge.
- 7) If the clearance is not within the factory specifications, turn the adjusting screw to adjust.

(Note)

- Engine must be cool.

Valve clearance IN. and EX.	Factory spec.	0.18 to 0.22 mm 0.0071 to 0.0087 in.
-----------------------------	---------------	---

[D1102-B, D1302-B, D1402-B]

Cylinder No.	1		2		3	
Valve	IN.	EX.	IN.	EX.	IN.	EX.
Checking	\circ	\circ	\bullet	\circ	\circ	\bullet

[V1502-B, V1702-B, V1902-B]

Cylinder No.	1		2		3		4	
Valve	IN.	EX.	IN.	EX.	IN.	EX.	IN.	EX.
Checking	\circ	\circ	\bullet	\bullet	\circ	\bullet	\bullet	\bullet

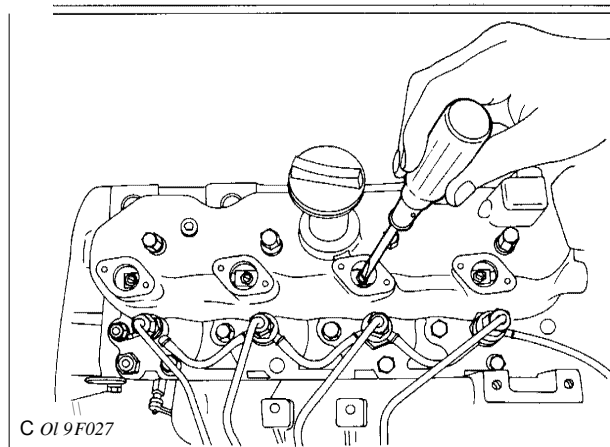

(A) Compression release adjustment

(a) Compression release window cover

(b) Compression position

(c) Compression release position

(d) 0.750 to 1.125mm
0.0295 to 0.0443 in.

C 019 F028

41.1 Adjustment of Compression Release

- 1) Close the exhaust valve completely.
- 2) Remove the decompression adjust cover from the head cover.
- 3) Pull the decompression lever.
- 4) Reduce the valve clearance to zero by means of the decompression adjuster. Gain access to the adjuster through the window. Then, screw in the bolt by 1 to 1.5 turns and tighten the lock nut.

(Note)

- After adjustment, turn the crankshaft by hand and check to see that the valve and the piston should not be in contact with each other because the decompression clearance is too small.

Reference value

0.750 to 1.125 mm
0.0295 to 0.0443 in.

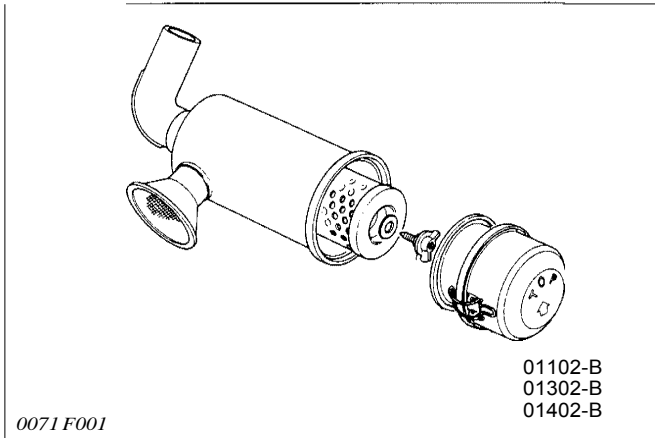

0071 F001

01102-B
01302-B
01402-B

CE, Cleaning Air Cleaner Element

For a dry type element

- 1) How to clean by using compressed air:
Directly blow compressed air from inside to outside.
Pressure of compressed air must be under 205kPa (2.1kgf/cm²,30psi).
- 2) How to clean by using solution:
Add 15 g (0.03 lb.) Kubota genuine element detergent to 1 liter (0.26 gal.) water. Let the element soak in the solution for 15 minutes and then wash it well in the solution. Rinse well in clean water and dry.

- To remove dirt and dust, use compressed air.
- To remove carbon and grease, use solution.

Reference value
Clean it every 100 hours, Replace every 6 cleanings.

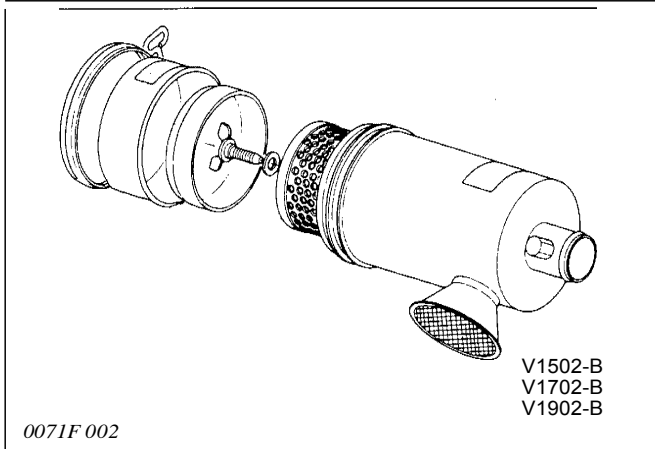

0071 F 002

V1502-B
V1702-B
V1902-B

FUEL SYSTEM

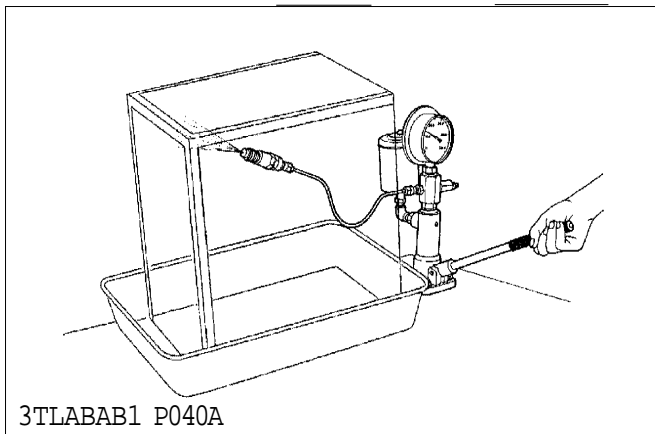

3TLABAB1 P040A

O Testing Opening Pressure of Nozzle

- 1) Move the tester handle up and down to prime fuel. Measure the pressure of fuel gushing out from the nozzle tip.
- 2) If the measurement is not within the reference value, adjust with the adjustment washer inside the nozzle holder. (See page 76) An increase of every 0.1 mm (0.0039 in.) of washer thickness causes an approximate 980.6 kPa. (10 kgf/cm² , 142.2 lb./sq.in.) increase in fuel injection pressure.

(Danger)

- Be careful not to touch the injected fumes directly. On touching flesh, the fumes destroy the organism. If it gets in the blood, it may cause blood poisoning.

Reference value

1990.8 to 2133.0 **1**
b.i.s

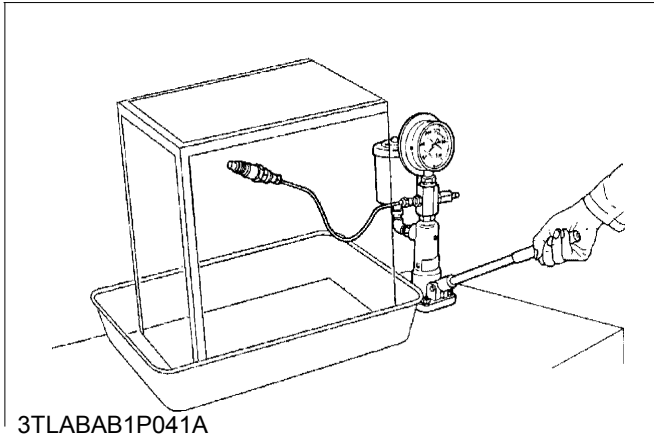

@ Checking Fuel-Tightness of Nozzle Valve Seat

- 1) Apply pressure 980.6 kPa. (10 kgf/cm², 142.2 lb./sq.in.) lower than the opening pressure.
- 2) After keeping the nozzle under the specified pressure for 10 seconds, check to see that fuel does not leak from the nozzle valve seat.
- 3) If the valve seat should leak fuel, replace the nozzle piece.

Reference value

When the pressure is 980.6 kPa. (10 kgf./cm², 142.2 lb./sq.in.) lower than the opening pressure, the valve seat must be oil-tight.

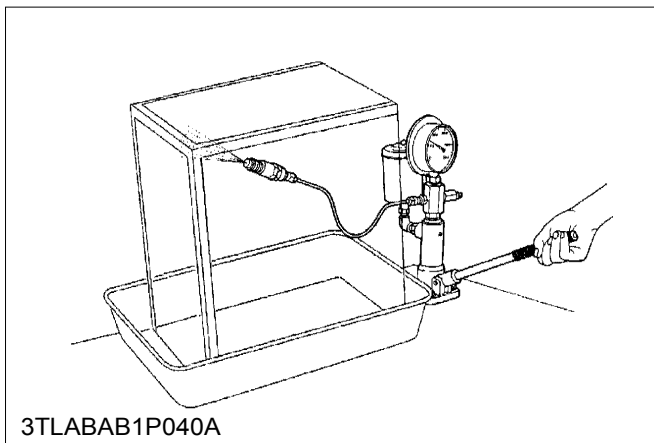

(t) Checking Shape of Fume across Nozzle Tip

- 1) Attach the nozzle to a nozzle tester and shoot it in the air. Check the shape of the fume.
- 2) If the shape is not acceptable, replace the nozzle piece.

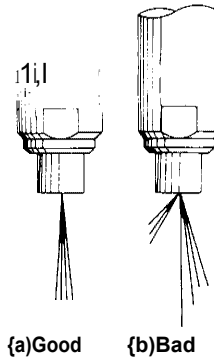

C 01 9 F033

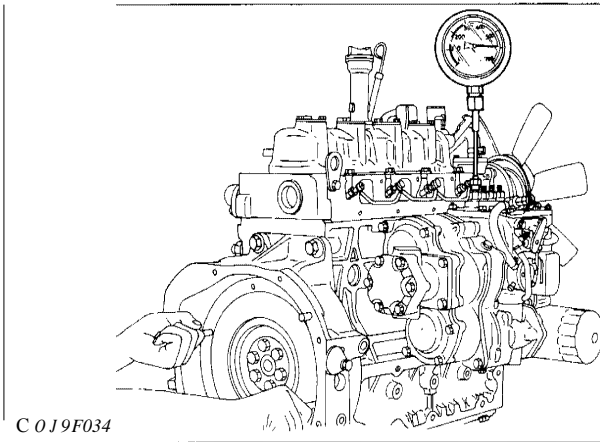

O Checking Fuel-Tightness of Fuel Injection Pump Plunger

- 1) Attach a pressure gauge to the pump.
- 2) Rotate the flywheel to increase the pressure to 58.8 MPa. (600 kgf/cm² 8532 lb./sq.in.).
- 3) Align the plunger with the top dead center.
- 4) Measure the time needed to decrease the initial pressure from 58.8 MPa. to 49.0 MPa. (600 kgf/cm² to 500 kgf/cm² 8532 lb./sq.in. to 7110 lb./sq.in.)
- 5) If the measurement is not acceptable, replace the pump element. In this case, ask a repair shop to do the replacement. Be sure to give them adjustment reference data on the fuel injection pump. (Shown left)

(A) Profile of fuel pump cam

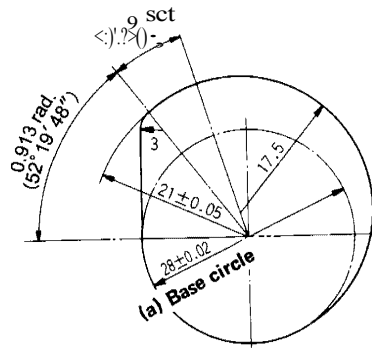

Reference value	8 seconds or more
Allowable limit	4 seconds or less

- Adjustment reference data of fuel injection pump
- Test Conditions
 - Nozzle DN12SD12
 - Opening pressure 13.73MPa(140 kgf/cm²)
 - Pipe 6 mm in diameter x 2 mm in diameter x 600 mm
 - Fuel feed pressure 19.6 kPa (0.2 kgf/cm²)
 - Cam profile See Fig. below.
 - Prestroke 2.2 ± 0.05 mm
 - Test fuel Diesel Fuel No.2-D

• Adjustment of injection

Control rack position (*1)	Speed (min ⁻¹ (rpm))	Amount of injection (mm ³ /st)	Allowance (mm ³)(*3)
9	1400	23 ± 1.5	± 1.5 or less
8	1400	18.5 ± 7.5	± 3.8 or less
7	1400	13.5 ± 7.5	± 3.8 or less
0 to 3.5	1550	0 (*2)	

*1 Travel distance from non-injecting point of control rack

*2 Zero opening pressure and no injection

*3 Allowance on the basis of standard cylinder

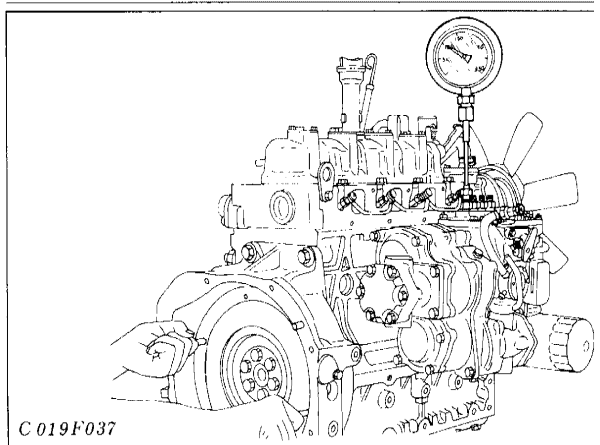

O Checking Fuel-Tightness of Delivery Valve of Fuel Injection Pump

- 1) Attach a pressure gauge to the pump.
- 2) Rotate the flywheel to increase the pressure to 9.8 MPa. (100 kgf/cm², 1422 lb./sq.in.).
- 3) Align the plunger with the bottom dead center.
- 4) Measure the time needed to decrease the initial pressure from 9.8 MPa. to 490.3 kPa. (100 kgf/cm² to 5 kgf/cm² 1422 lb./sq.in. to 71.1 lb./sq.in.)
- 5) If the measurement is not acceptable, replace the delivery valve.

Reference value	10 seconds or more
Allowable limit	5 seconds or less

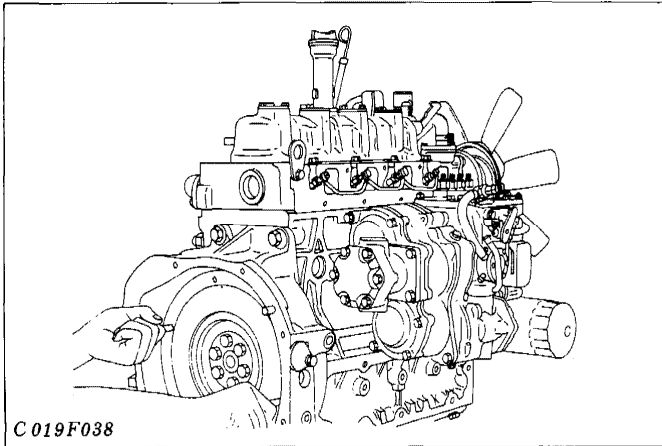

C 019F038

(A) Fuel injection timing

(a) FI mark type (b) Markless type

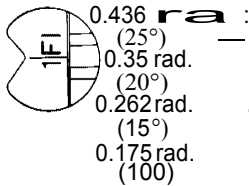

A069F004

(B) Adjustment of injection timing

(a) Injection timing adjusting shim

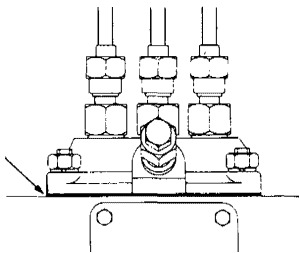

C 019F039

C, Checking and Adjusting Injection Timing

- 1) Remove the injection pipes.
- 2) Set the speed control lever to maximum fuel discharge position.
- 3) Turn the flywheel counterclockwise (facing the flywheel) until the fuel fills up to the hole of the delivery valve holder for 1st cylinder.
- 4) Turn the flywheel further and stop turning when the fuel begin to flow over, to get the present injection timing.
- 5) [FI mark type] (The flywheel has marks TC and FI for each cylinder on its outer rim) If the FI mark does not align with the projection in the window on flywheel housing, add or remove the shim to adjust.
- 6) [Markless type] (The flywheel has mark 1TC and four lines indicating every 0.087 rad. (5°) of crank angle from 0.175 rad. (10°) to 0.436 rad. (25°) before mark 1TC) Calculate the angle which the projection in the window points out. If the calculation differs from specified injection timing, add or remove the shim to adjust.

Injection timing	Factory spec.	0.401 to 0.436 rad. (23 to 25°) before TDC
------------------	---------------	---

- NOTE
- Apply liquid gasket (Three Bond 1215 or equivalent) to the shim, when reassembling.

(Reference)

- The timing advances by removing 0.15 mm (0.006 in.) of shim and retards by adding one, approx. 0.26 rad. (1.5°) of crank angle.

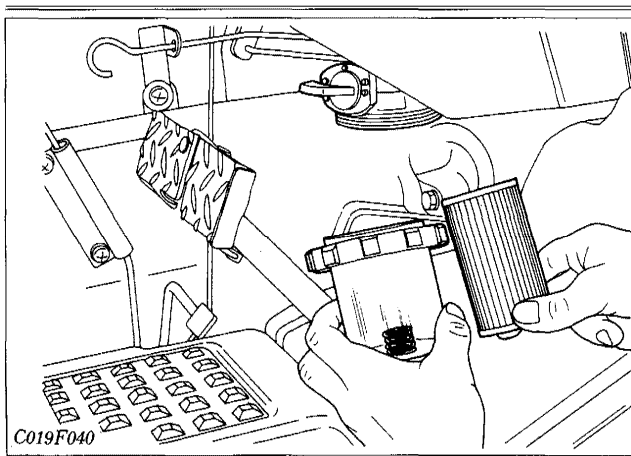

C019F040

@ Replacing Fuel Filter

- 1) Detach the filter with a filter wrench.
- 2) Replace the filter with a new one.

Reference value	Replace every 400 hours
-----------------	-------------------------

TIMING GEAR, CAMSHAFT

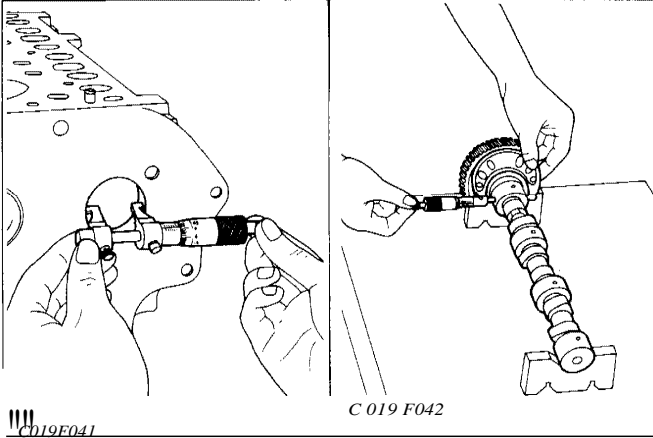

O Checking Oil Clearance of Camshaft

- 1) Measure the camshaft bearing in the crankcase with a inside micrometer.
- 2) Measure the camshaft journal with a outside micrometer. Calculate the clearance.
- 3) If the measurement exceeds the allowable limit, replace the camshaft.

Reference value	0.050 to 0.091 mm 0.0020 to 0.0036 in.
Allowable limit	0.15 mm 0.0059 in.

O.D of camshaft bearing journal	39.934 to 39.950 mm 1.5722 to 1.5728
I.D of camshaft bearing	40.000 to 40.025 mm 1.5748 to 1.5758

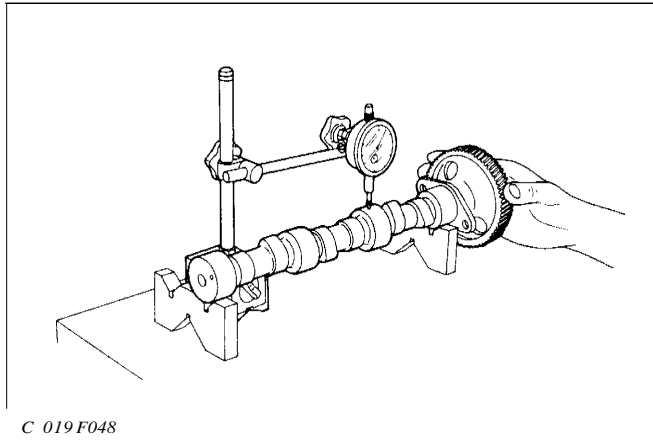

f) Checking Camshaft Alignment

- 1) Gently put the camshaft on V blocks.
- 2) Set a dial gauge on the journal.
- 3) While slowly rotating the camshaft, read the dial gauge. The camshaft flexure is indicated by half of the reading.
- 4) If the measurement exceeds the allowable limit, replace the camshaft.

	Reference value
Allowable limit	0.01 mm 0.004 in.

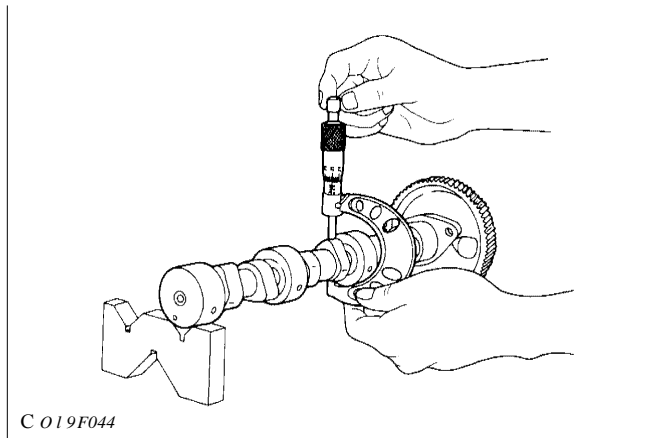

@ Checking Cam Heights of Intake and Exhaust

- 1) Measure the highest point of the cam with a micrometer.
- 2) If the measurement exceeds the allowable limit, replace.

Reference value	33.36 mm 1.3134 in.
Allowable limit	33.31 mm 1.3114 in.

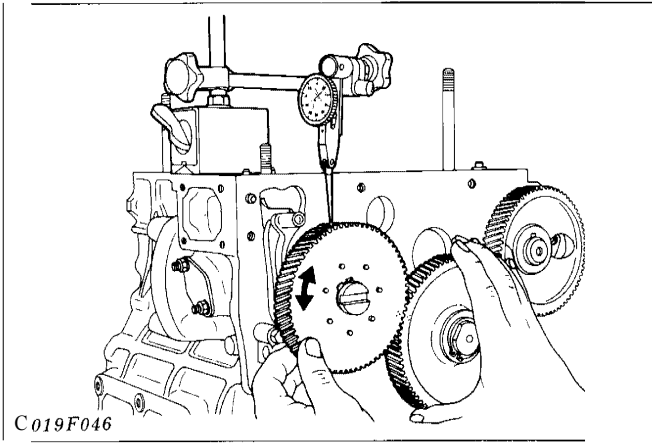

C, Checking Gear Backlash

- 1) Install a lever-type indicator between gear teeth.
- 2) Clamp one gear, rotate the other, and measure the backlash.
- 3) Replace if the measurement exceeds the allowable limit.

Reference value	0.042 to 0.115 mm 0.0017 to 0.0045 in.
Allowable limit	0.15 mm 0.0059 in.

C019F046

LUBRICATION

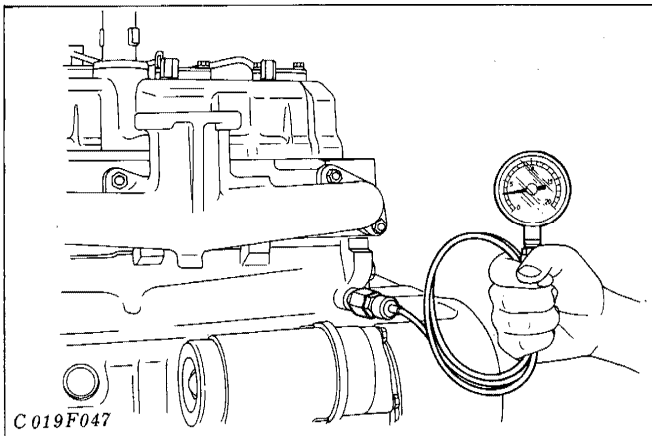

O Testing Oil Pressure

- 1) Detach the oil switch and attach a pressure gauge.
- 2) Start the engine. Measure oil pressures both at idling and the rated speed running.
- 3) If the measurement is not within the reference range, check the oil pump, the oilways, the oil clearances and the pressure-regulating valve.

(Note for measuring)

- Supply the specified amount of genuine oil.
- Keep the oil filter from being clogged or torn.

	Reference value
At idling speed	Approx. 98.1 kPa. or more Approx. 1.0 kgf/cm ² or more Approx. 14.2 lb./sq.in. or more
At rated engine speed	294.2 to 441.3 kPa. 3.0 to 4.5 kgf/cm ² 42.7 to 64.0 lb./sq.in.

C019F047

Oil Pump (Rotor Type)

(1) Checking Rotor Lobe Clearance

- 1) Mate the projections of the inner and outer rotors. Insert a feeler gauge into the gap between the projections.
- 2) Replace if the measurement exceeds the allowable limit.

Model	Reference value	Allowable limit
D1102-B D1302-B D1402-B	0.10 to 0.16 mm 0.0039 to 0.0063 in.	0.20 mm 0.0079 in
V1502-B V1702-B V1902-B	0.04 to 0.13 mm 0.0016 to 0.0051 in.	

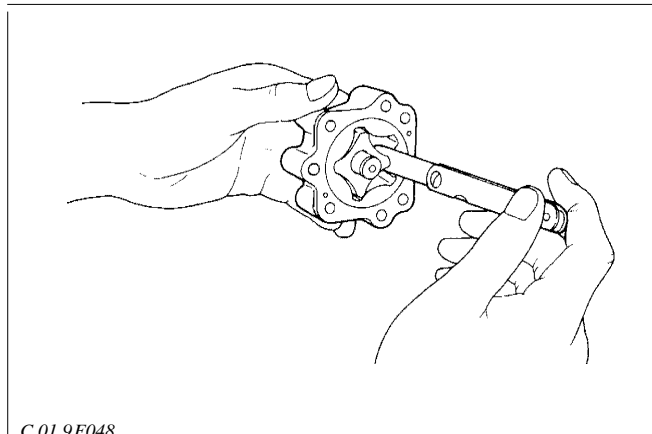

C019F048

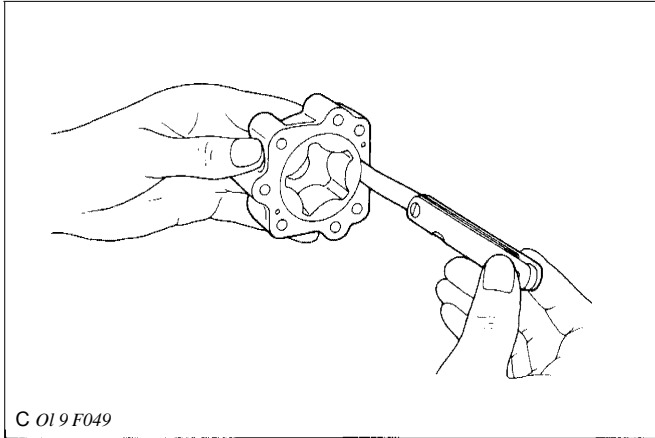

(2) Checking Radial Clearance between Oil Pump Outer Rotor and Body

- 1) Insert a feeler gauge into the gap between the body and the outer rotor.
- 2) If the measurement exceeds the allowable limit, replace.

Reference value	0.11 to 0.19 mm 0.0043 to 0.0075 in.
Allowable limit	0.25 mm 0.0098 in.

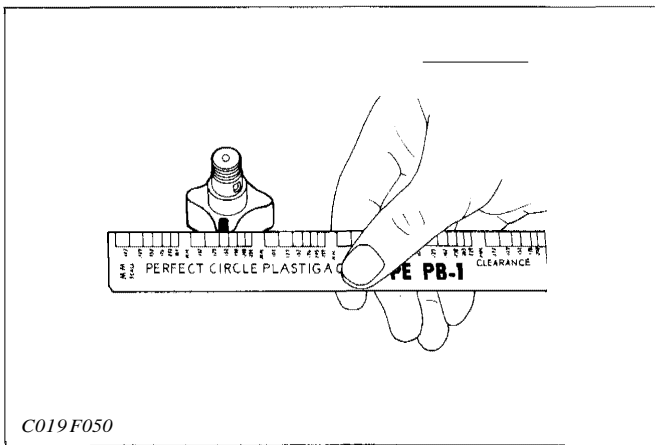

(3) Checking End Clearance between Rotor and Cover

- 1) Paste a press gauge with grease on the surface of the gear.
- 2) Attach the cover.
- 3) Detach the cover carefully, and measure the depression of the press gauge with a sheet of gauge (paper).
- 4) If the measurement exceeds the allowable limit, replace.

Reference value	0.105 to 0.150 mm 0.0041 to 0.0059 in.
Allowable limit	0.2 mm 0.0079 in.

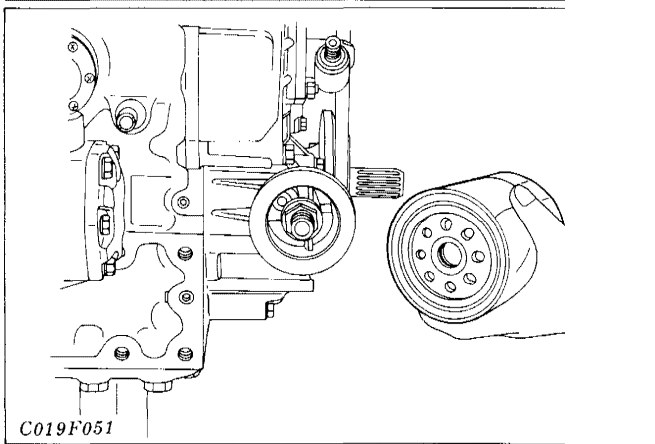

(D) Checking and Replacing Oil Filter

- 1) Detach the filter with a filter wrench.
- 2) Replace the oil filter cartridge.

(Note for reassembling)

- Apply a thin coat of oil to packing and tighten it securely by hand.

Reference value	Replace every 200 hours (Initial 50 hours)
-----------------	---

PISTON, CONNECTING ROD

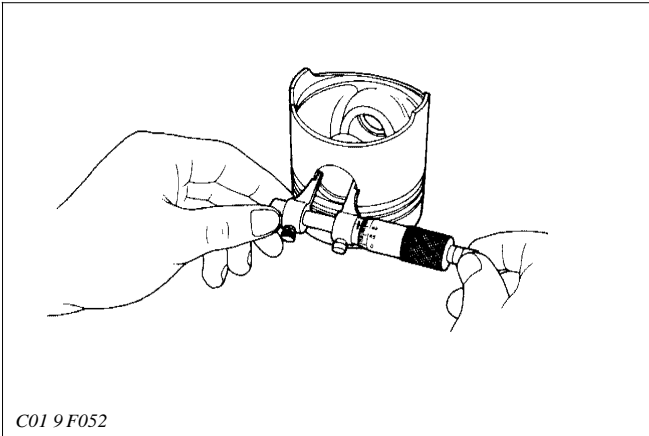

C019 F052

0 Checking Inside Diameter of Piston Bosses

- 1) Measure the piston pin hole with an inside micrometer.
- 2) If the measurement exceeds the allowable limit, replace it.

Reference value	23.000 to 23.013 mm 0.9055 to 0.9060 in.
Allowable limit	23.053 mm 0.9076 in.

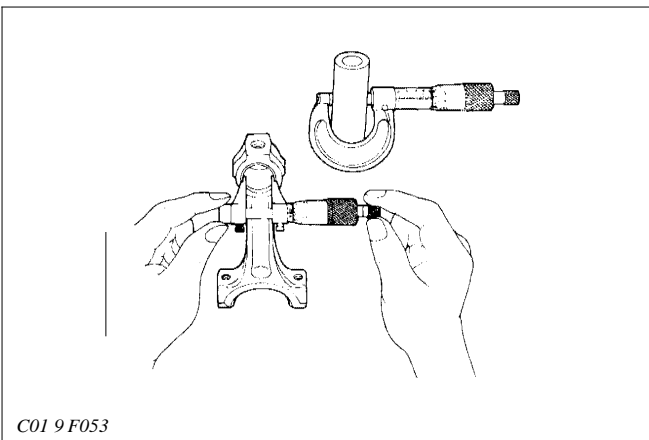

C019 F053

Checking Clearance between Piston Pin and Rod Small-End Bushing

- 1) Measure the piston pin with an outside micrometer.
- 2) Measure the inside diameter of rod small-end bushing with an inside micrometer. Calculate the clearance.
- 3) If the clearance exceeds the allowable limit, replace it.

Reference value	0.014 to 0.038 mm 0.0006 to 0.0015 in. 0.015 to 0.067 mm [Service Part 0.0006 to 0.0026 in.]
Allowable limit	0.15 mm 0.0059 in.

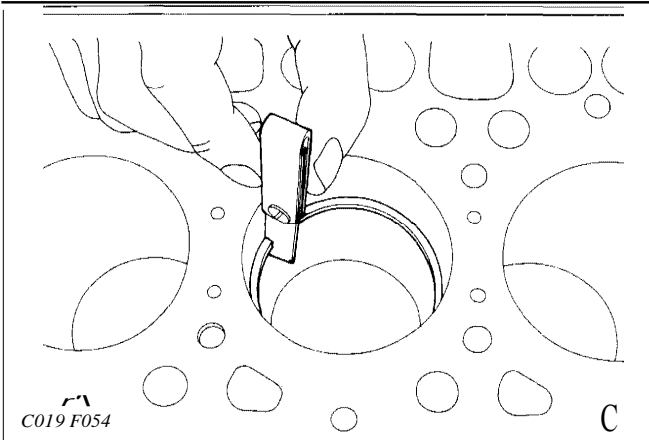

C019 F054

8 Checking Piston Ring Gap

- 1) Put the piston ring in the cylinder.
- 2) Stand the piston upside down and push the ring into the cylinder with the piston head.
- 3) Insert a feeler gauge into the piston ring gap.
- 4) If the measurement exceeds the allowable limit, replace it.

(Important)

- Measure the piston ring gap at the point of the minimum inside diameter of the cylinder liner.

	Reference value	Allowable limit
Top ring	0.30 to 0.45 mm	1.25 mm 0.0492 in.
Second ring	0.0118 to 0.0177 in.	
Oil ring	0.25 to 0.45 mm 0.0098 to 0.0177 in.	

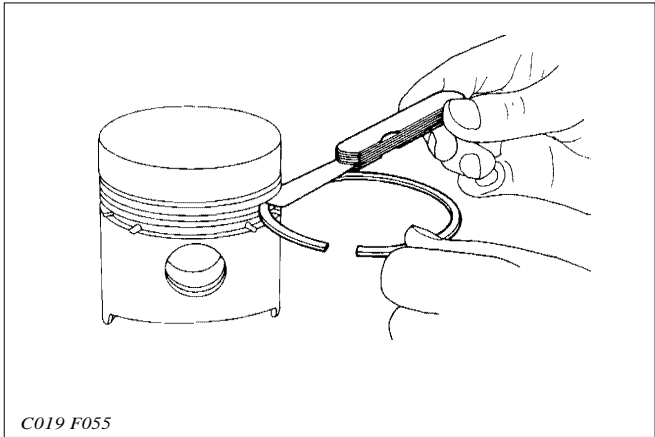

C019 F055

O Checking Side Clearance of Ring in Groove

- 1) Remove the piston ring from the piston.
- 2) Place the ring in its groove as is shown at left, and measure the clearance.
- 3) If the measurement is not within the reference value, replace the ring.

(Note)

- As the top ring is a keystone type, it cannot be measured by this method.

	Reference value
Second ring	0.093 to 0.120 mm 0.0037 to 0.0047 in.
Oil ring	0.020 to 0.052 mm 0.0008 to 0.0020 in.

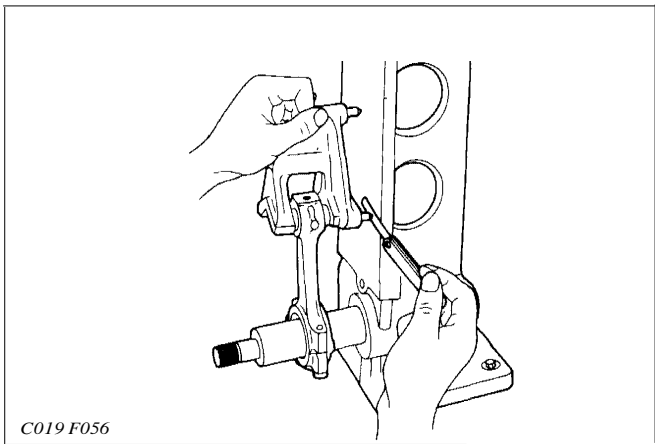

C019 F056

O Checking Connecting Rod Alignment

- 1) Remove the connecting rod crank pin metal and tighten the rod bolt.
- 2) Attach the connecting rod to the connecting rod aligner.
- 3) Place the gauge on the piston pin.
Measure the gap between the pin of the gauge and the flat surface of the aligner.
- 4) If the measurement exceeds the allowable limit, replace the rod.

(Important)

- Because the inside diameter of the connecting rod small-end bushing is used as the basis, check carefully if it is worn or not.

Reference value	0.02 mm	0.0008 in
Allowable limit	0.05 mm	0.0020 in

CRANKSHAFT

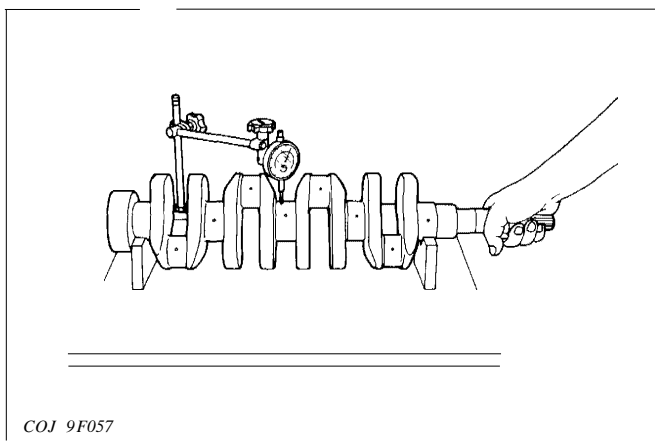

COJ 9F057

O Checking Crankshaft Alignment

- 1) Place V-blocks on a surface plate, and put either end of the journal on them.
- 2) Set a dial gauge on the center journal.
- 3) Read the dial gauge while rotating the crankshaft slowly.
Crankshaft flexure is indicated by half of the reading.
- 4) If the reading exceeds the allowable limit, replace the crankshaft.

Reference value	0.02 mm 0.0008 in.
Allowable limit	0.08 mm 0.0031 in.

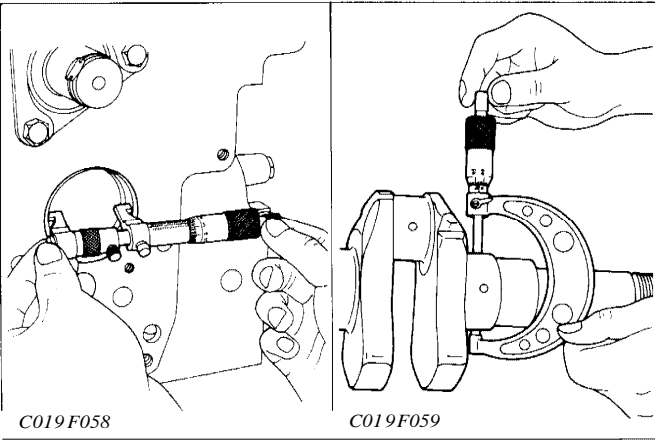

Checking Oil Clearance between Crankshaft Journal and Crankshaft Bearing 1

- 1) Measure the crankshaft journal (on the side of the crankshaft bearing 1) with an outside micrometer.
- 2) Measure the crankshaft bearing 1 with an inside micrometer. Calculate the clearance.
- 3) If the clearance exceeds the allowable limit, replace the crankshaft bearing 1 with an undersize one. For undersize bearing use, follow the precautions noted below.
 1. Cut corner, radius of the crank journal to precisely $3.0R \pm 0.2 \text{ mm}$ ($0.1181 R \pm 0.0079 \text{ in.}$)
 2. The crank journal must be fine-finished to higher than $\nabla \nabla \nabla \nabla$ (0.4S.)
 3. Be sure to chamfer the oil hole circumference with an oil stone.

(A) Crank journal for undersize bearing 1

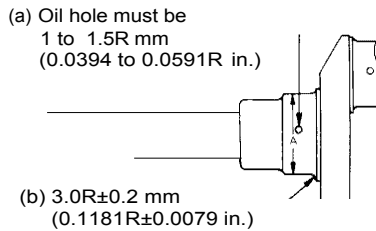

0071 F008

Reference value	0.040 to 0.118 mm 0.0016 to 0.0046 in.
Allowable limit	0.2 mm 0.0079 in.

Undersize	Code Number	Part Name	Crankshaft journal dia A (Shown in Fig.)	Bearing Mark
0.2 mm 0.0079 in.	15221-2391-1	Crankshaft bearing 1 0.2 minus	51.721 to 51.740 mm 2.0363 to 2.0370 in.	020 US
0.4 mm 0.0157 in.	15221-2392-1	Crankshaft bearing 1 0.4 minus	51.521 to 51.540 mm 2.0284 to 2.0291 in.	040 US

O.D. of crankshaft journal	I.D. of crankshaft bearing 1
51.921 to 51.940 mm 2.0441 to 2.0449 in.	51.980 to 52.039 mm 2.0465 to 2.0488 in.

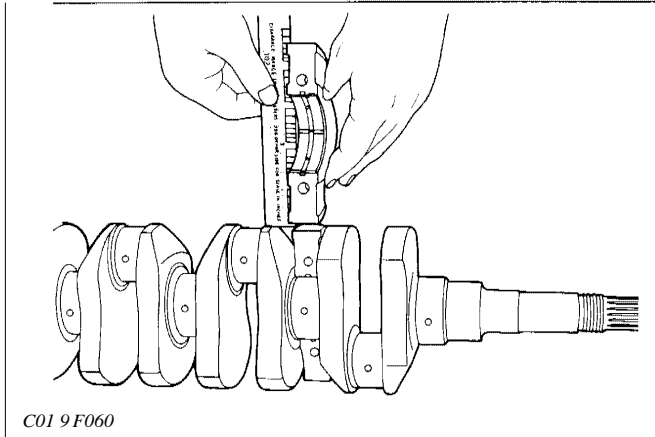

(A) Crank journal for undersized bearing 2.

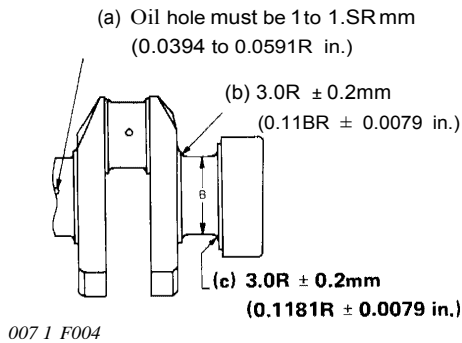

Checking Oil Clearance between Crankshaft Journals and Crankshaft Bearing 2

- 1) Paste a press gauge with grease on the crankshaft bearing 2.
- 2) Tighten the bearing case onto the crank journal to the specified torque (29.4 to 34.3 N·m, 3.0 to 3.5 kgf·m, 21.7 to 25.3 lb.ft.).
- 3) Detach the bearing case slowly, and measure the depression of the press gauge with a sheet of gauge (paper).
- 4) If the measurement exceeds the allowable limit, replace the crankshaft bearing 2 with undersize one. For undersize bearing use, follow the precautions noted below.
 - 1) Cut corner radius of the crank journal to precisely 3.0R±0.2 mm (0.1181R±0.0079 in.).
 - 2) The crank journal must be fine-finished to higher than \sqrt{Vv} (0.4S).

(Note for measuring)

- 1) Fasten the crankshaft such that it does not turn.
- 2) Do not insert the press gauge into the crank pin holes.

Reference value	0.040 to 0.104 mm 0.0016 to 0.0041 in.
Allowable limit	0.20 mm 0.0079 in.

O.D. of crankshaft journal	I.D. of crankshaft bearing
51.921 to 51.940 mm 2.0441 to 2.0449 in.	51.980 to 52.025 mm 2.0465 to 2.0482 in.

Undersize	Code Number	Part Name	Crankshaft journal dia B (shown in Fig.)	Bearing Mark
0.2 mm 0.0079 in.	15221-2393-1	Crankshaft bearing 2 0.2 minus	51.721 to 51.740 mm 2.0363 to 2.0370 in.	020 US
0.4 mm 0.0157 in.	15221-2394-1	Crankshaft bearing 2 0.4 minus	51.521 to 51.540 mm 2.0284 to 2.0291 in.	040 US

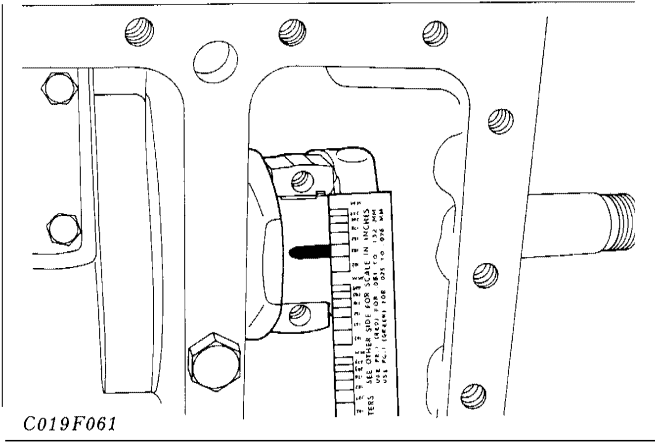

(A) Crank pin for undersized bearing

(a) $3.5R \pm 0.2\text{mm}$
(0.1378R \pm 0.0079 in.)

(b) Oil hole must be 1 to 1.5Rmm
(0.0394 to 0.0591R in.)

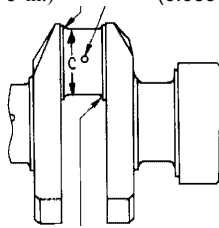

0071 F005

(c) $3.5R \pm 0.2\text{mm}$
(0.1378R \pm 0.0079 in.)

(B) Crank pin measuring points

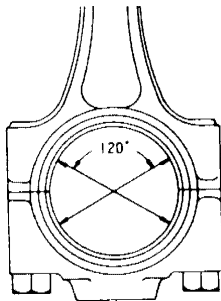

COJ9F062

Checking Oil Clearance between Crank Pins and Crank Pin Bearings

- 1) Paste a press gauge with grease on the crank pin bearing.
- 2) Tighten the connecting rod onto the crank pin to the specified torque (36.3 to 41.2 N-m., 3.7 to 4.2 kgf.m., 26.8 to 30.4 lb.ft.)
- 3) Remove the large end cap carefully, and measure the depression of the press gauge with a sheet of gauge (paper).
- 4) If the standard-size bearing cannot be employed due to excessive wear of the crank pin, employ undersize bearing. For undersize bearing use, follow the precautions noted below.
 1. Cut corner radius of the crank pin to precisely $3.5R \pm 0.2\text{mm}$ (0.1378R \pm 0.0079 in.)
 2. Be sure to chamfer the oil hole circumference with an oil stone.
 3. The crank pin must be fine-finished to higher than \sqrt{VVV} (0.4S).

Reference value	0.035 to 0.093 mm 0.0014 to 0.0037
Allowable limit	0.20 mm 0.0079 in.

(Note for measuring)

- 1) Fasten the crankshaft so that it does not turn.
- 2) Do not insert the press gauge into the crank pin hole.
- 3) Crank pin metal measuring points are shown below:

O.D. of crank pin	I.D. of crank pin bearing
43.959 to 43.975 mm 1.7307 to 1.7313 in.	44.010 to 44.052 mm 1.7327 to 1.7343 in.

Model	Undersize	Code Number	Part Name	Crank pin dia. C (Shown in Fig.)	Bearing Mark
01102-B	0.2 mm	15221-2297-1	Crank pin bearing 0.2 minus	43.759 to 43.775 mm 1.7228 to 1.7234 in.	020 US
01302-B	0.0079 in.				
V1502-B	0.4 mm	15221-2298-1	Crank pin bearing 0.4 minus	43.559 to 43.575 mm 1.7149 to 1.7156 in.	040 US
V1702-B	0.0157 in.				
D1402-B	0.2 mm	15471-2297-1	Crank pin bearing 0.2 minus	43.759 to 43.775 mm 1.7228 to 1.7234 in.	020 US
V1902-B	0.0079 in.				
	0.4 mm	15471-2298-1	Crank pin bearing 0.4 minus	43.559 to 43.575 mm 1.7149 to 1.7156 in.	040 US
	0.0157 in.				

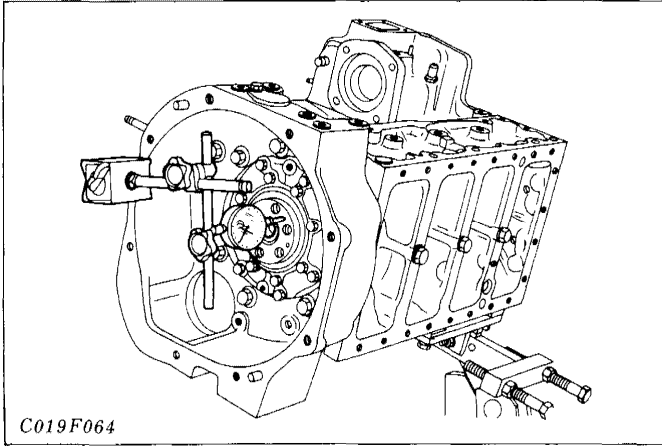

(A) Crank journal for oversized side metal.

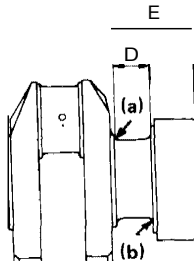

(a) $3.0R \pm 0.2\text{mm}$
(0.1181 R \pm 0.0079 in.)

(b) $3.0R \pm 0.2\text{mm}$
(0.1181R \pm 0.0079 in.)

0071 F006

C, Checking End Play of Crankshaft

- 1) Move the crankshaft to the crank gear side.
- 2) Set a dial gauge on the crankshaft.
- 3) Push the crankshaft toward the flywheel and measure the clearance.
- 4) If the measurement exceeds the allowable limit, replace the side metal with oversize one.
For oversize metal use, follow the precautions noted below.
 1. Grind the crankpin and journal with a wheel which has specified round corner and width without shoulder.
 2. The crank journal side surface must be fine-finished to higher than (0.4S).
 3. Be sure to chamfer the oil hole circumference to 1 to 1.5 mm (0.04 to 0.06 in.) radius with an oil stone.

		Dimension "E"
Oversize	0.2 mm 0.008 in.	54.6 to 54.8 mm 2.149 to 2.157 in.
	0.4 mm 0.016 in.	54.8 to 55.0 mm 2.157 to 2.165 in.

- When replacing the side metal, face the oil grooves of side metal outwards. (See page 48).

Reference value	0.15 to 0.31 0.0059 to 0.01
Allowable limit	0.5 mm 0.0197 in.

Oversize	Code Number	Part Name	Distance D (Shown in Fig.)	Metal Mark
0.2 mm 0.0079 in.	15221-2395-1	Crankshaft side metal 1 0.2 plus	26.40 to 26.45 mm 1.0394 to 1.0413 in.	020 OS
	15221-2397-1	Crankshaft side metal 2 0.2 plus		
0.4 mm 0.0157 in.	15221-2346-1	Crankshaft side metal 1 0.4 plus	26.40 to 26.85 mm	040 OS
	15221-2398-1	Crankshaft side metal 2 0.4 Plus		

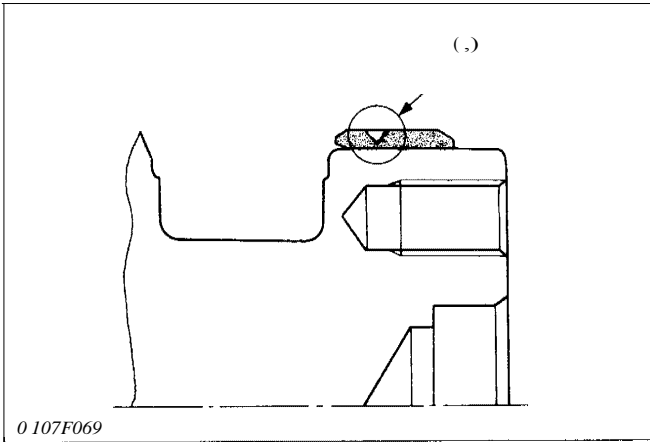

(it) Crankshaft Sleeve Wear

- 1) Measure the wear of the crankshaft sleeve using a surface roughness tester.
- 2) If the measurement exceeds the allowable limit, replace the crankshaft sleeve.

Crankshaft sleeve wear	Allowable limit	0.1 mm 0.0039 in

(1) Wear

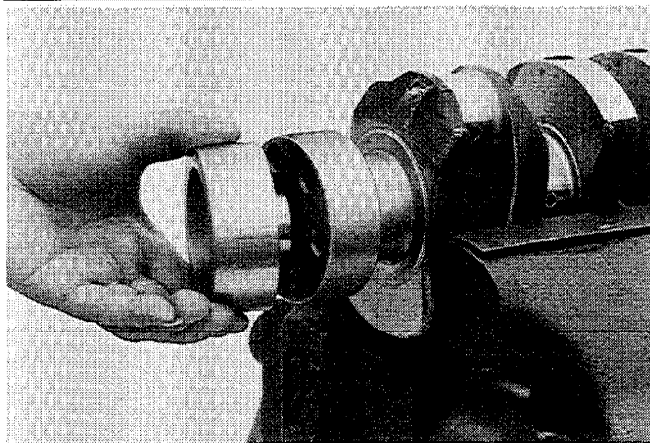

@ Replacing Crankshaft Sleeve

- 1) Remove the used crankshaft sleeve using a special-use puller set (Code No. 07916-09032).
- 2) Set the sleeve guide (4) to the crankshaft.
- 3) Set the stopper (5) to the crankshaft as shown in figure.
- 4) Heat a new sleeve to a temperature between 150 and 200°C (302 and 392°F), and fix the sleeve to the crankshaft as shown in figure.
- 5) Press fit the sleeve using the auxiliary socket for pushing (3).

• **Tool: Auxiliary socket for fixing the crankshaft sleeve (Code No. 07916-32091)**

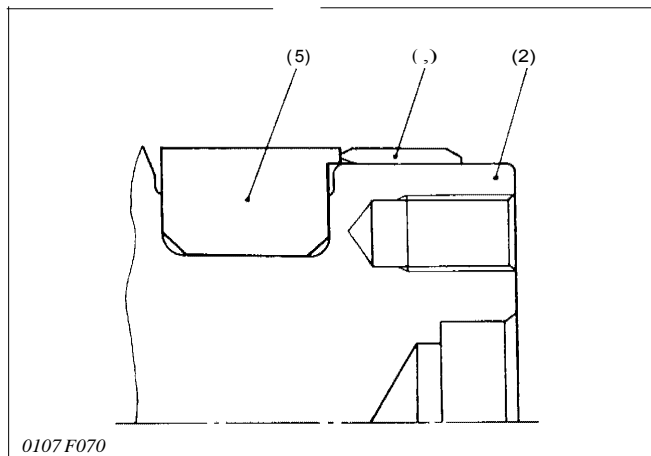
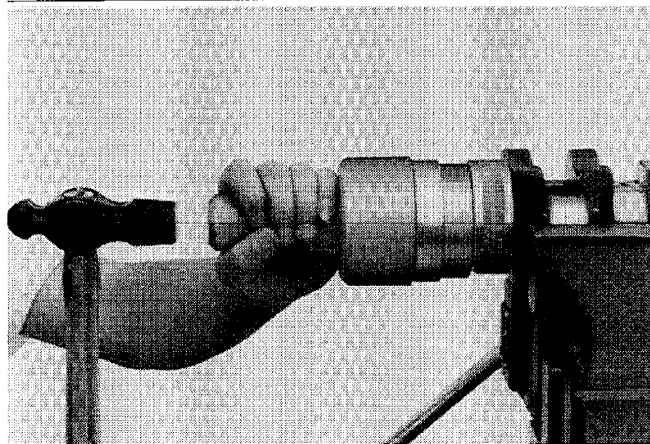

- (1) Crankshaft Sleeve
- (2) Crankshaft
- (3) Auxiliary Socket for Pushing
- (4) Sleeve Guide
- (5) Stopper

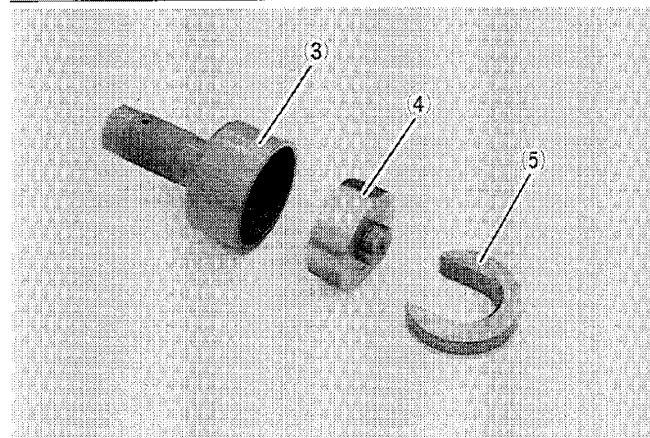

CYLINDER LINER

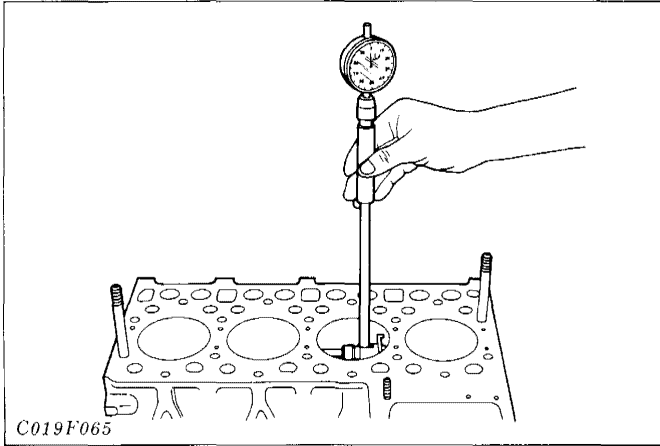

(A) Measuring points of cylinder liner

- (B) 1) Top
2) Middle
3) Bottom (Skirt)

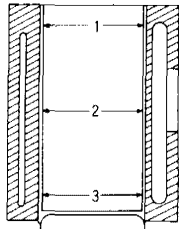

C019 F066

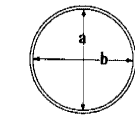

- (C) a) Right-angled in relation to the piston pin
b) In the direction of the piston pin

O Checking Wear of Cylinder Liner

- 1) Adjust a cylinder gauge to a reference value of cylinder liner with an outside micrometer.
- 2) To find out the maximum wear, measure six points of cylinder diameters with the cylinder gauge, as shown below.

- When the cylinder liner has worn beyond the allowable limit, bore and hone the cylinder by 0.5 mm (0.0197 in.)
 - 1) Finish the cylinder liner to the degree in Table 1.
 - 2) The cylinder liner which has been oversized by 0.5 mm (0.0197 in.) should use a piston and ring of the same oversize. (See the Table 2)
- When the oversized cylinder liner is worn beyond the allowable limit, replace the cylinder liner, and bore and hone it.

Model	Reference value	Allowable limit
D1102-B V1502-B	76.000 to 76.019 mm 2.9921 to 2.9929 in.	+0.15 mm +0.0059 in.
D1302-B V1702-B	82.000 to 82.022 mm 3.2283 to 3.2292 in.	
D1402-B V1902-B	85.000 to 85.022 mm 3.3465 to 3.3473 in.	

Table 1

Model	Oversized Cylinder Liner	1
D1102-B V1502-B	76.500 to 76.519 mm 3.0118 to 3.0126 in.	Hone to 1.2 to 2 μ R max.
D1302-B V1702-B	82.500 to 82.522 mm 3.2480 to 3.2489 in.	
D1402-B V1902-B	85.500 to 85.522 mm 3.3661 to 3.3670 in.	

Table 2

Oversize	Model	Code Number	Part Name	Mark
0.5 mm 0.0197in.	D1102-B	15221-2191-1	Piston 05	05 OS
	V1502-B	15501-2109-1	Piston 19 05 assembly	
	D1302-B	15201-2191-1	Piston 05	
	V1702-B	15201-2109-1	Piston ring 05 assembly	
	D1402-B	15521-2191-1	Piston 05	
	V1902-B	15521-2109-1	Piston ring 05 assembly	

COOLING SYSTEM

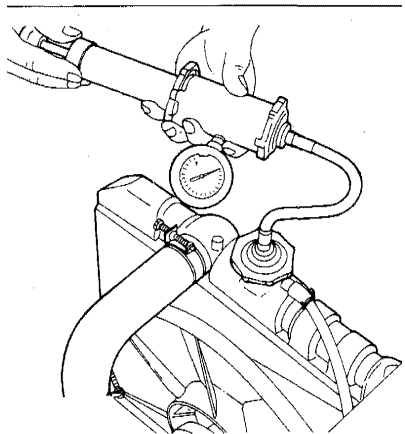

C042F055

0 Testing Water Tightness of Radiator

- 1) Pour the specified amount of water into the radiator.
- 2) Start engine warm-up.
- 3) Attach a radiator tester. Increase water pressure to the specified pressure 88.3 kPa. (0.9 kgf/cm², 12.8 lb./sq.in.).
- 4) Check to see if water leaks from any part.

Reference value
Water tight at specified pressure (88.3 kPa, 0.9 kgf/cm ² , 12.8 lb./sq.in.)

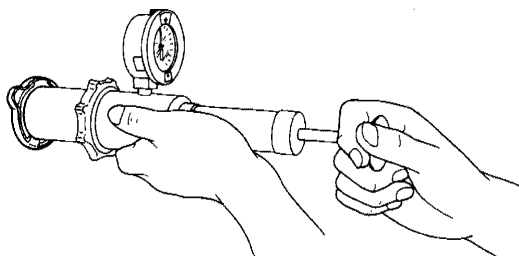

C019F068

f) Testing Opening Pressure of Radiator Cap

- 1) Attach a radiator tester to the radiator cap.
- 2) Apply the specified pressure 88.3 kPa. (0.9 kgf/cm², 12.8 lb./sq.in.).
- 3) Check that the pressure does not drop by more than 29.4 kPa. (0.3 kgf/cm², 4.3 lb./sq.in.) in 10 seconds.

Reference value
Pressure should not drop by more than 29.4 kPa. (0.3 kgf/cm ² , 4.3 lb./sq.in.) in 10 seconds.

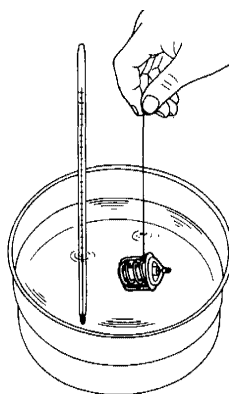

C019F069

8 Testing Operating Temperature of Thermostat

- 1) Place a thermostat and a thermometer in water and heat the water.
- 2) Check to see if the thermostat begins to open at 80.5 to 83.5°C (176.9 to 182.3°F).
- 3) Check to see if the thermostat opens fully around 95°C (203°F).
- 4) If the measurement is not acceptable, replace the thermostat.

Reference value		
Temperature at which thermostat should start to open	Temperature at which thermostat opens completely	Distance: lift
80.5 to 83.5°C 176.9 to 182.3°F	95°C 203°F	8 mm 0.3150 in.

(a) Fan pulley (b) Alternator pulley

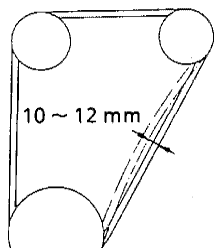

(c) Fan drive pulley

C019F070

8 Checking and Adjusting Fan Belt Tension

- 1) Check to see if belt tension allows a depression of the specified amount when the belt is pressed down by the thumb midway between the fan pulley and the alternator pulley.
- 2) To adjust the tension, move the alternator position.

Reference value
10 to 12 mm 0.394 to 0.472 in. When the belt is pressed down with pressure of 98 N.(10 kgf., 221b.)

Section N

ELECTRICAL SYSTEM

1. TROUBLESHOOTING	72
2. ALTERNATOR AND REGULATOR	
Checks	76
Disassembly and Reassembly	80
Servicing.....	81
3. STARTER AND GLOW PLUG	
Checks	85
Disassembly and Reassembly	88
Servicing.....	92

1. TROUBLESHOOTING

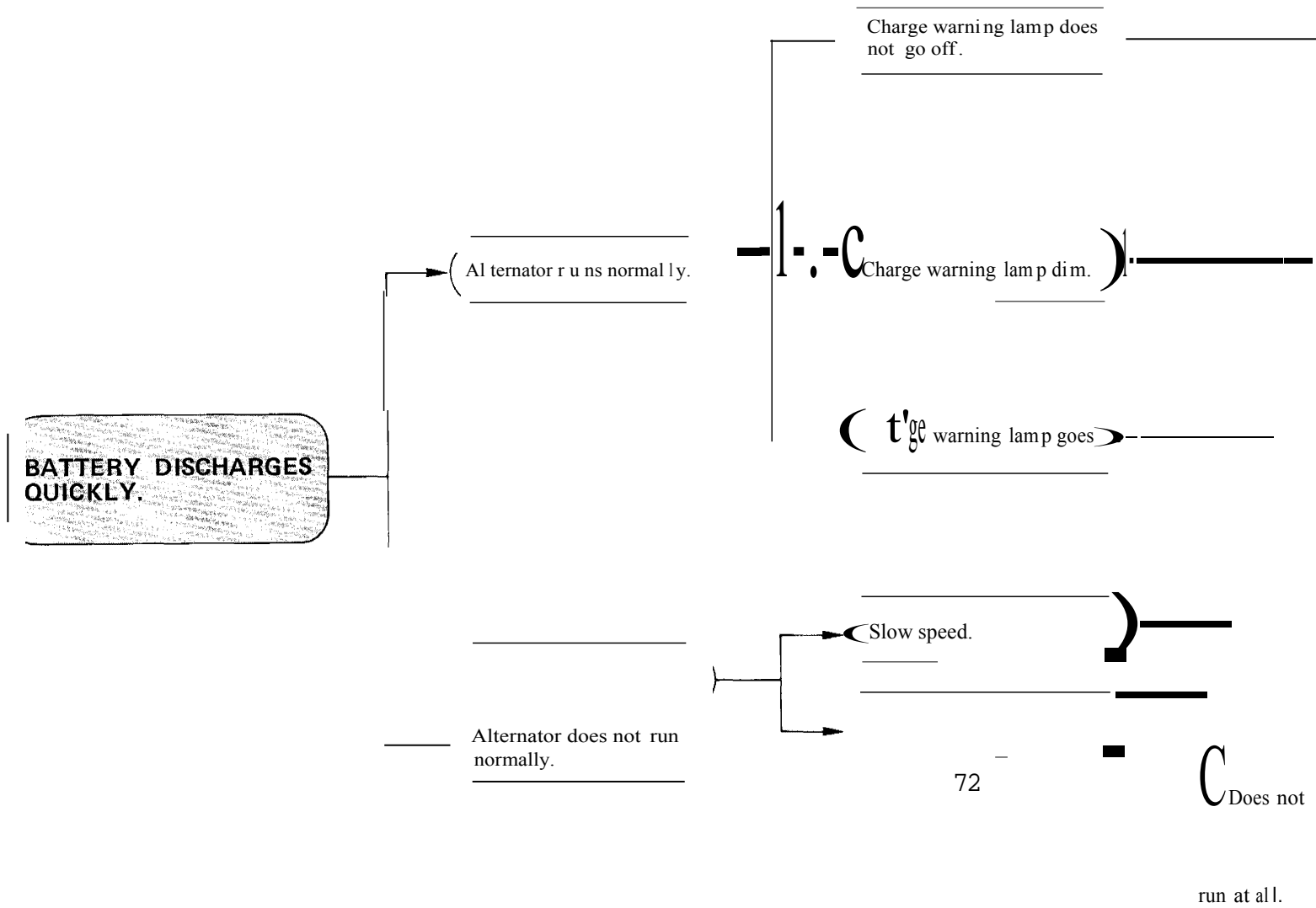

)1-----

Incorrect wiring.

Coupler disconnects from alternator.

76

Faulty alternator.

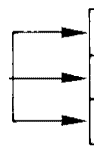

Faulty rotor.
Faulty stator.
Faulty rectifier.

76.77
78
81.82
76.77
78
83.84
76.77
78
83.84

Faulty regulator.

Faulty voltage relay

Incorrect wiring.

Incorrect wiring between alternator and regulator.

Faulty regulator.

Faulty voltage relay.

Charging current too low.

Faulty alternator.

Charging current normal.

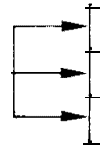

Faulty battery.	
Alternator speed too slow.	
Extra electrical loads (such as lamp) installed.	

Fan belt slips.	70
Alternator V-pulley slips.	80

Fan belt broken.

STARTER DOES NOT DRIVE ENGINE PROPERLY.

Slow enginespeed.

Starter runs but engine does not.

Not meshing sound from pinion and ring gear

Pinion shifts repeatedly

GLOW PLUG INDICATOR DOES NOT TURN RED PROPERLY.

Does not turn red at all.

Turns red too quickly

—

—

Faulty battery.	Battery not sufficiently charged.	
	Terminal contact poor.	
	Poor grounding.	

Faulty starter.	Over-running clutch slips.	95
	Poor contact of contact plate.	85,86
	Poor contact between brush and commutator.	92,94
	Armature and field coil shorted.	85,86 93,94
	Bearing worn.	95,96

Pinion and ring gear do not mesh.	Pinion and ring gear worn.	
	Plunger and shaft distorted.	
	Pinion gap excessive.	

Clutch slips.	Over-running clutch worn.	95
---------------	---------------------------	----

Pinion does not pop out by the attraction force of magnet switch.	Main switch faulty.	
	Faulty magnet switch.	85,86 87
	Screw spline rusted.	
	Faulty battery.	

Faulty battery.	Battery not sufficiently charged.	
	Poor terminal contact.	
	Grounded poorly.	

Faulty magnet switch.	Holding coil broken.	
-----------------------	----------------------	--

Faulty battery	Battery not charged sufficiently	
	Poor terminal contact.	
	Poorly grounded.	

Incorrect wiring	Incorrect wiring between battery and glow plug.	
	Glow plug indicator disconnected.	
	Glow plug disconnected.	
	Main switch or starter switch faulty.	

Circuit shorted.	Shorted between glow plug indicator and glow plug.	
	Glow plug indicator shorted.	
	Glow plug shorted.	87
	Glow plug cable shorted.	

rt:

2.ALTERNATOR AND REGULATOR

CHECKS

Checking Sequence

If the charging system is malfunctioning, check as follows to find the cause.

- (A) Output current check (1)
- (B) Coupler voltage check (2)
- (C) No load testing of alternator (3)
- (D) Rotor coil, slip ring and brush check (4)
- (E) Cut-in Voltage check (5)
- (F) No-load regulating voltage check (6)
- (G) Regulator check (7)

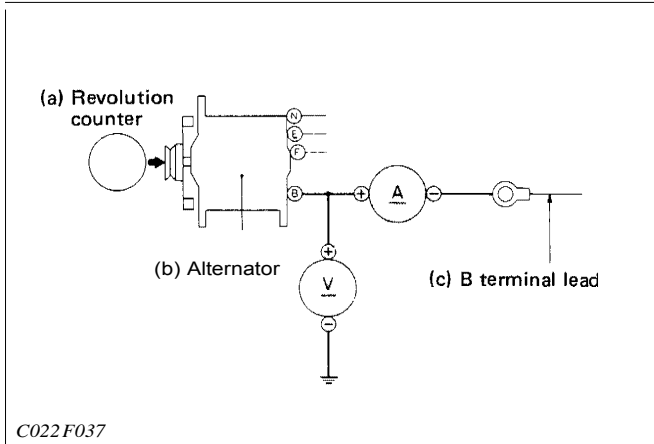

0 Checking Output Current

- 1) Disconnect the cable from the alternator's B terminal and connect an ammeter and voltmeter to B terminal. Then switch on all electrical loads (such as lights) and read the meters.

(Note for checking)

- Be sure to disconnect the battery's negative cable before setting the ammeter and voltmeter.
- When the electrical load is considerably low or the battery is fully charged, the specified reading cannot be obtained.

	Reference value
Output current	25A
Voltage	14V
Rotational speed	4000 (min ⁻¹ (rpm))

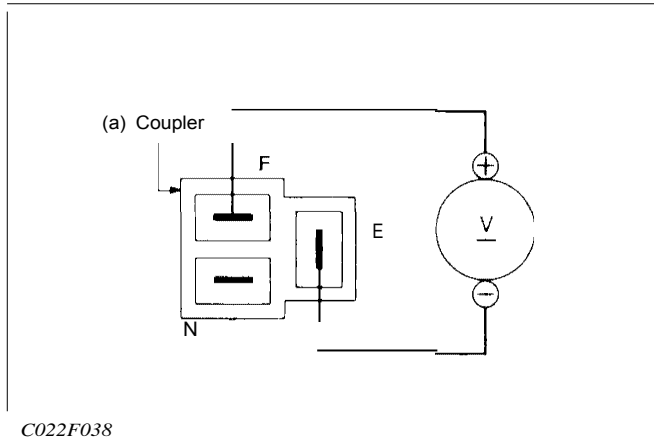

f) Checking Coupler Voltage

- 1) Remove the coupler from the alternator.
- 2) Turn the main switch on and then measure the voltage across the alternator coupler's F and E terminals.

Reference value

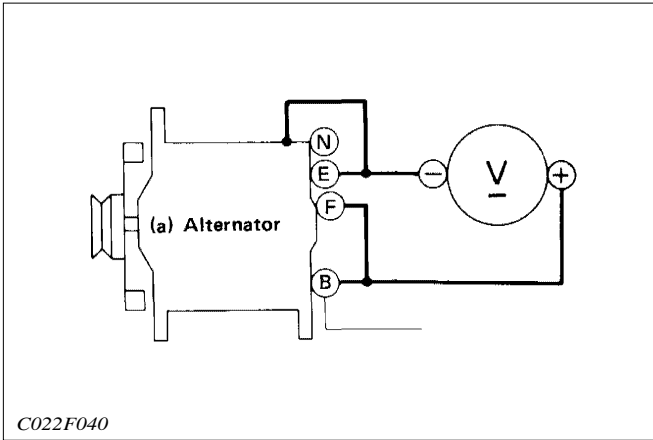

@) No- Load Testing of Alternator

- 1) Remove the alternator's coupler, connect the alternator's **F** terminal to B terminal, and ground E terminal to the body.
- 2) Connect a voltmeter across B terminal and the ground.
- 3) Start the engine and speed up the alternator to the specified rate $1300 \text{ min}^{-1}(\text{rpm})$ Next, turn the main switch off, disconnect the battery's negative cable and measure the voltage.

(Note for testing)

- Be sure to disconnect the battery's negative cable before setting the voltmeter.

	Reference value
Voltage	14V
Rotational speed	1050 to 1350 $\text{min}^{-1}(\text{rpm})$

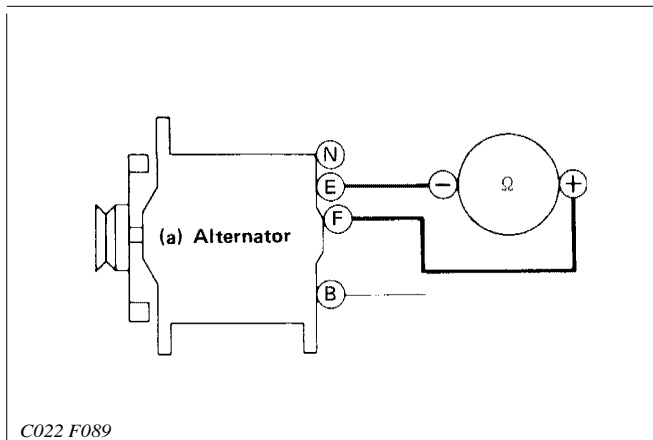

8 Checking Rotor Coil, Slip Ring and Brush

- 1) Disconnect the alternator coupler and then measure the resistance across the alternator's F and E terminals.

Reference value	_____
Allowable limit	_____

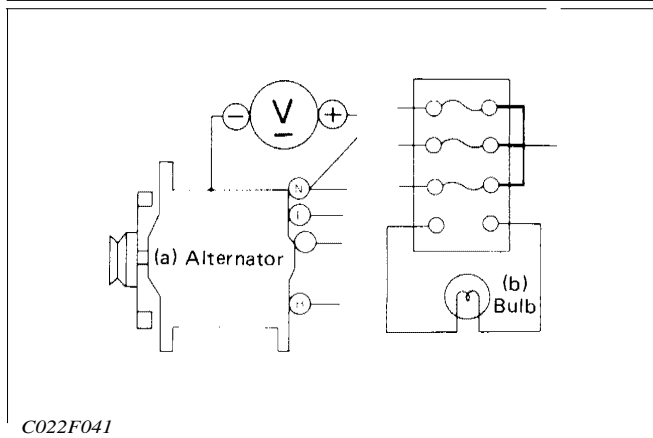

0 Checking Cut-In-Voltage

- 1) Connect a voltmeter across the alternator's N terminal and the body.
- 2) Remove the 4th 8A fuse from the left and connect a bulb (30W) in its place.
- 3) Speed up the alternator until the charge warning lamp goes off or dims, then read the voltmeter.

Reference value	4.5 to 5.8V
-----------------	-------------

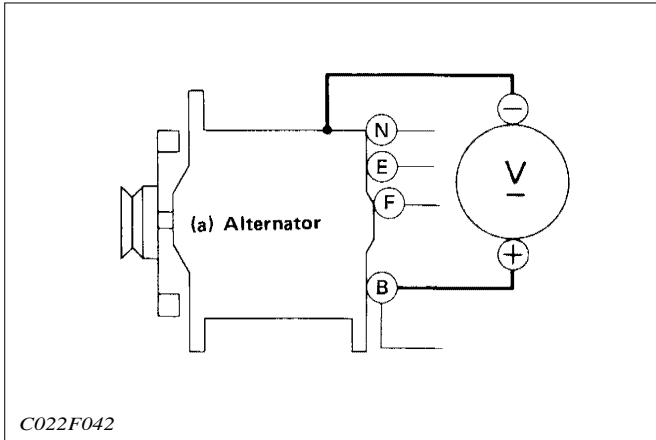

0 Checking No-Load Regulating Voltage

- 1) Connect a voltmeter across the alternator's B terminal and the ground.
- 2) Start the engine, speed up to a rate (approx. 1300 min⁻¹ (rpm)) where the alternator is self-excited, and disconnect the battery's negative cable.
- 3) Read the voltmeter while gradually accelerating the engine.

(Note for checking)

- Be sure to gradually accelerate the engine while reading the voltmeter. Never obtain the specified engine speed by decelerating the engine from maximum speed.

Reference value

13.8 to 14.8V

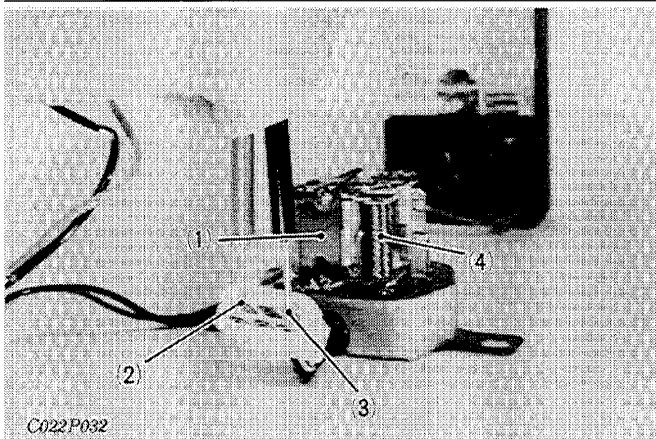

- (1) Voltage regulator
- (2) I.G. (Black/white)
- (3) F (White/green)
- (4) Voltage relay

Regulator

(1) Checking Test Terminals IG-F

- 1) Connect a circuit tester across the regulator's coupler IG (black/white) and F (white/green) terminal and measure the resistance.
- 2) If the reading exceeds zero ohms, the voltage regulator's low-speed side contact is faulty.

Reference value

Voltage regulator in stationary state 0Ω

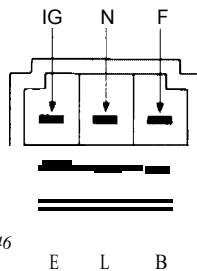

C022F046

(2) Checking Test Terminals IG-F

- 1) Connect a circuit tester across IG (black/white) and F (white/green) and read the tester while pressing the voltage regulator with a finger.
- 2) If the reading is infinity, the control resistor is broken.

Reference value

Voltage regulator in pull state approx. 11Ω

- (1) I.G. (black/white)
- (2) F (white/green)

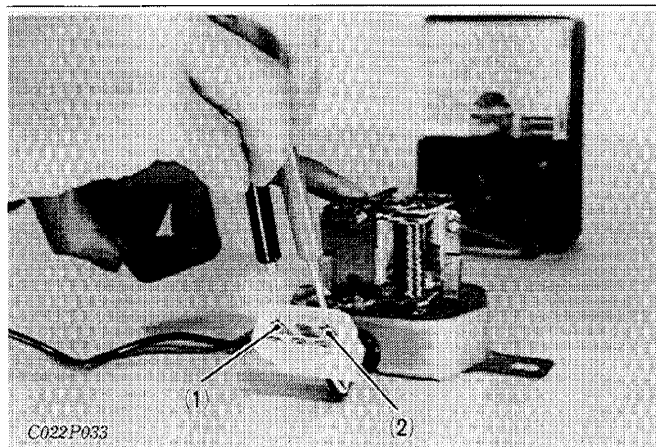

(3) Checking Test Terminals L-E/N-E/B-E/B-L

- l) Test the terminals L-E, N-E, B-E and B-L with the same method as above.
- Resistances of regulator
The nominal resistances between terminals of the regulator are given below for reference.

Terminals	Voltage Relay	Voltage Regulator	Normal Resistance Ω	Failure and Probable Causes
L - E (white/red) (black)	Stationary state	—	0	If reading is over 0, bad contact on voltage relay point P1.
	Pull	—	approx. 100	If reading is 0, deposition occurs on voltage relay point P1. If reading is ∞, voltage coil is cut.
N - E (white/black) (black)	Stationary state	—	approx. 23	If reading is 0, relay coil is shorted. If reading is ∞, pressure coil is cut.
B - E (white) (black)	Stationary state	—	∞	If reading is not ∞ voltage relay point P2 is melted and burned.
B - L (white) (white/red)	Pull	—	0	If reading is over 0, bad contact on voltage relay_point P2.

NOTES:

- "Pull" means the condition where the armature point is contacting the high-speed side point P2 with finger pressure only.
- "Stationary" means the condition where the armature point is in contact with the low-speed side point P1.

DISASSEMBLY AND REASSEMBLY

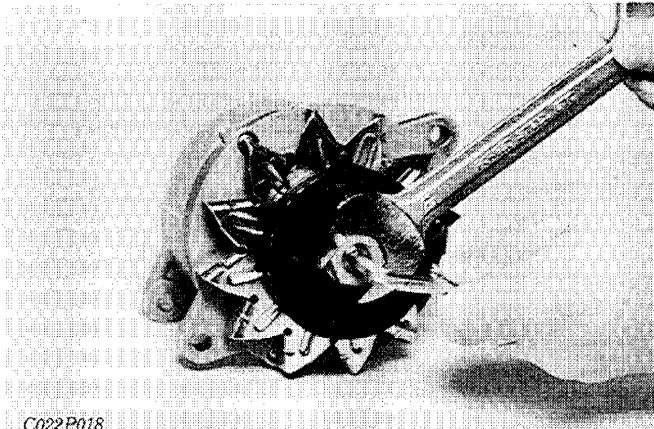

C022P018

O Removing Pulley

- 1) Clamp the shaft with a hexagonal wrench and remove the nut.
- 2) Remove the pulley.
- 3) Remove the fan.

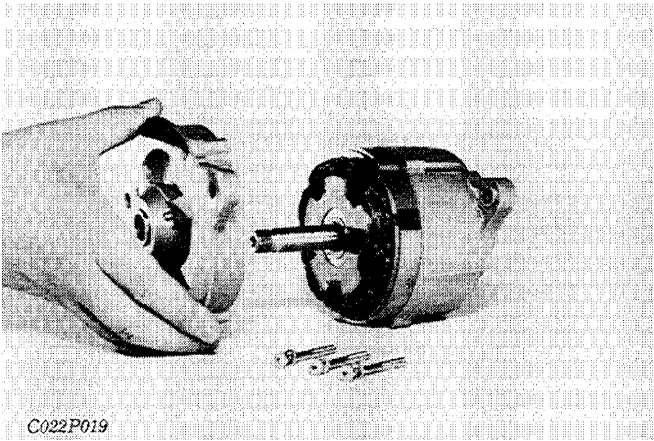

C022P019

@ Removing Drive Side End Frame

- 1) Remove the three through bolts.
- 2) Remove the drive end frame.

(Note for reassembling)

- Do not forget to refit the collar and the spacer.

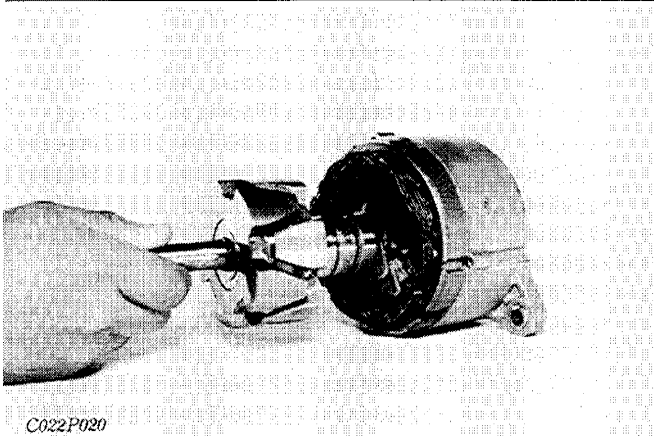

C022P020

C, Removing Rotor

- 1) Draw the rotor out.

(Note for reassembling)

- To refit the rotor, thread a wire through the access hole and lift the brush up with it.

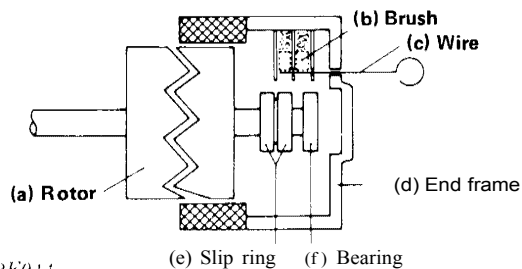

C022F044

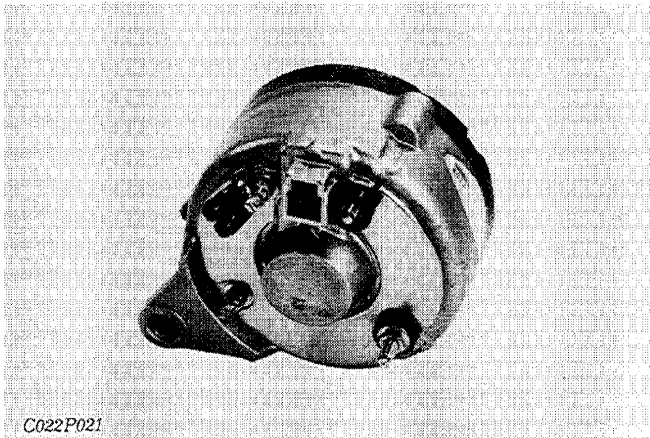

C022P021

0 Removing Rectifier

- 1) Remove the nuts.
- 2) Remove the end cover.
- 3) Remove the rectifier.

(Note for reassembling)

- Make sure the insulation washer on the positive diode holder.

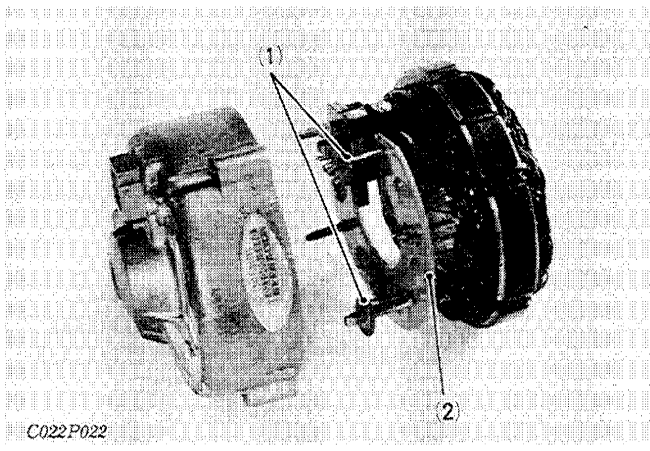

C022P022

- (1) Insulation washer
- (2) Positive diode holder

SERVICING

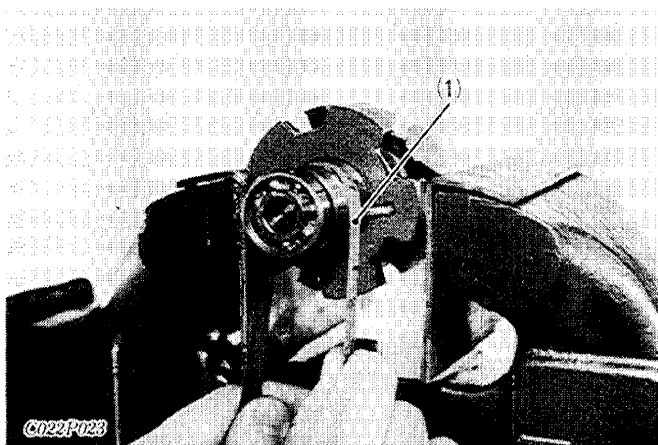

C022P023

0 Checking and Refining Slip Ring

- 1) Check to see if the slip ring is flawed.
- 2) If it is flawed, correct with sand paper or on a lathe.

- (1) Sand paper

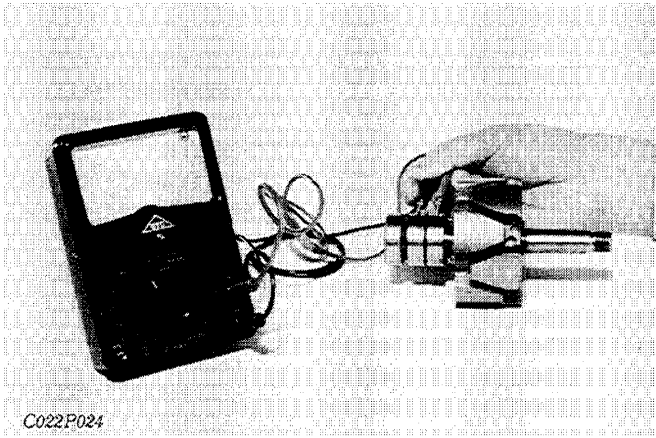

C022P024

f) Checking Rotor Coil Resistance

- 1) Measure the resistance across the slip rings.
- 2) If the measurement is above or under the reference value, replace.

Reference value	Approx. 4.2Ω
-----------------	--------------

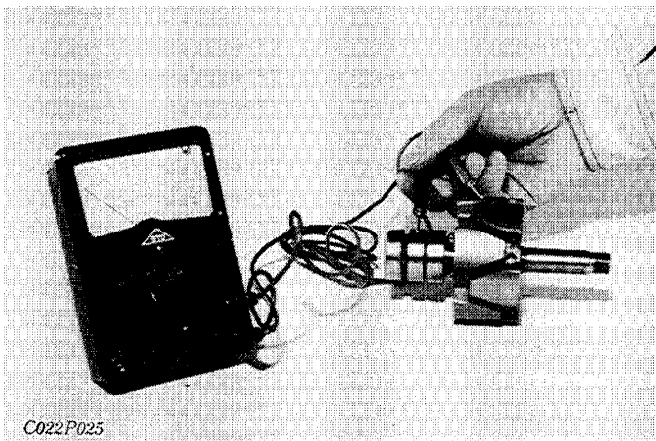

C022P025

@ Grounding of Rotor Coil

- 1) Check conduction across the slip ring and core.
- 2) If conducting, replace.

Reference value	Should not be conducted
-----------------	-------------------------

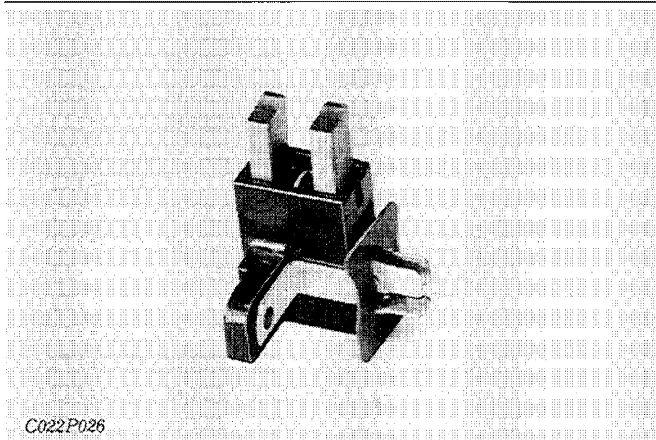

C022P026

O Checking Brush Wear

- 1) Check the length of the brush. If the length is shorter than the limit, replace it.
- 2) Make sure that no powder clings to the brush and that the brush moves smoothly.
- 3) If the brush is faulty, replace.

	Reference value
Allowable limit	Longer than 10.5mm

• Brush dimensions

Length	Width	Thickness
15.5mm 0.6102in.	8.0mm 0.3150in.	5.0mm 0.1969in.

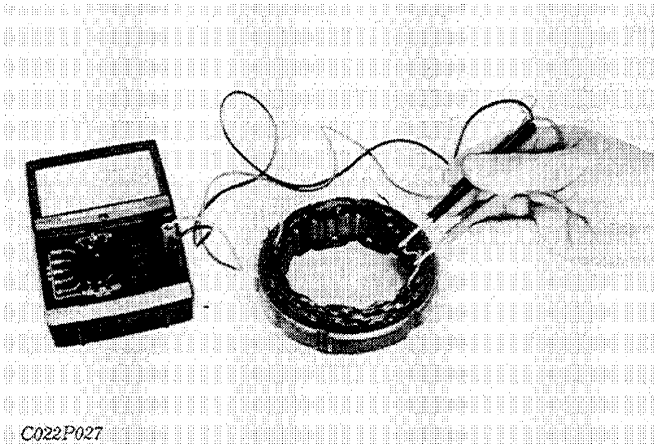

C022P027

- Stator coil

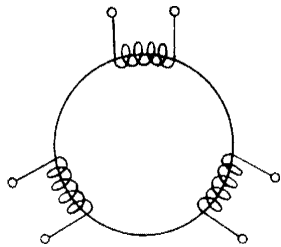

C022F045

(3) Checking Stator Coil Breakage

- 1) Check conduction across each leads of the stator coil.
- 2) If not conducting, replace.

Reference value	Should be conducted
-----------------	---------------------

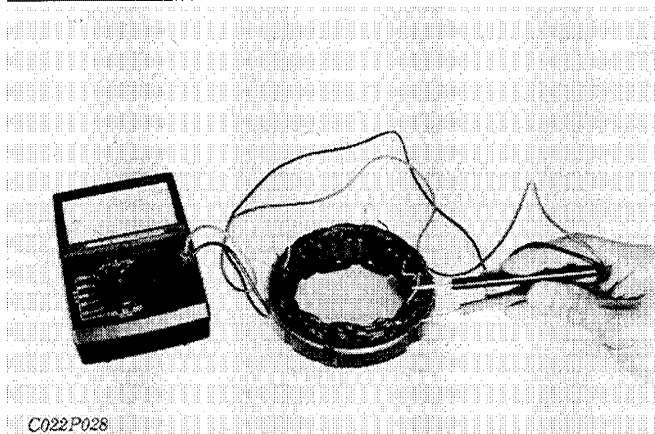

C022P028

@ Grounding of Stator Coil

- 1) Check conduction across the stator coil's terminal and core.
- 2) If conducting, replace.

Reference value	Should not be conducted
-----------------	-------------------------

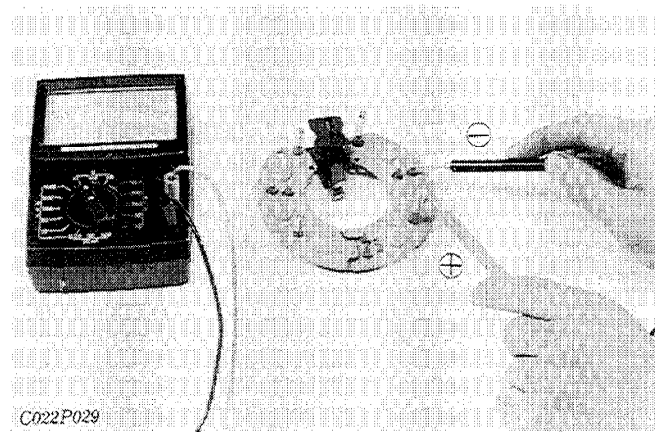

C022P029

@ Checking Positive Diodes

- 1) Check the conduction across each M6 screw and coil connecting terminal (outside).
- 2) If any diode is faulty, replace its whole positive diode assembly.

(Important)

- When reassembling, remember that diodes are very sensitive to heat.

Reference value

If the ohmmeter indicates a specified value when the positive probe is applied to the M6 screw and the negative probe to the coil connecting terminal, and if it indicates infinity when the probes are reversed, the positive diodes are normal.

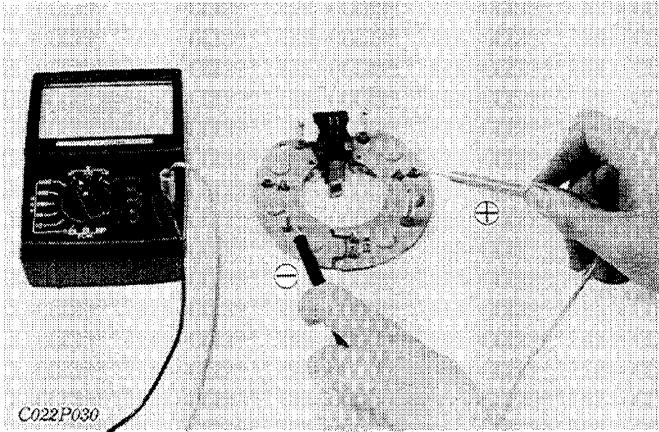

Checking Negative Diodes

- 1) Check the conduction across each M5 screw and coil connecting terminal (outside).
- 2) If any diode is faulty, replace its whole negative diode assembly.

(Important)

- **When reassembling, remember that diodes are very sensitive to heat.**

Reference value
If the ohmmeter indicates a specified value when the positive probe is applied to the coil connecting terminal and the negative probe to the M5 screw, and if it indicates infinity when the probes are reversed, the negative diodes are normal.

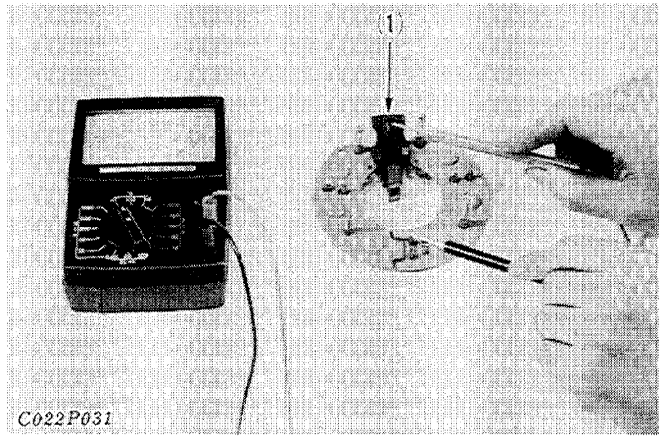

C)) Checking Conduction across N Terminal and Coil Connecting Terminal

- 1) Check the conduction across N terminal and coil connecting terminals (inside).
- 2) If not conducting, replace.

Reference value	Should be conducted

(1) N terminal

J.STARTER AND GLOW PLUG

CHECKS

Checking Sequence

If the starter system malfunctions, do the following checks to locate the cause:

- (A) Check the circuit -----
- (B) Battery terminal check ---
- (C) Wiring check '-----
- (D) Test the starter at no-load (1). -----
- (E) Motor test (2). -----
- (F) Magnet switch check (3). O-----

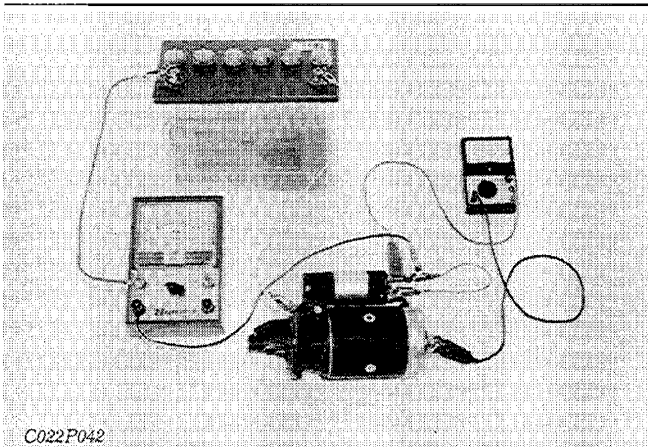

No-Load Testing of Starter

- 1) Connect the ammeter's positive probe to the battery's positive terminal and the negative probe to the starter's B terminal.
- 2) Connect the battery's negative terminal to the starter body.
- 3) Connect the voltmeter's positive probe to the starter's B terminal and the negative probe to the starter body.
- 4) Set a tachometer.
- 5) Connect the starter's B terminal to the magnet switch's S terminal.
- 6) Check to see that the magnet switch is operating and that the specified speed, current and voltage are obtained.

(Note for checking)

- Use a fully charged battery.
- Use an ammeter and leads of about 200A rating because a large current flows when the starter is running.

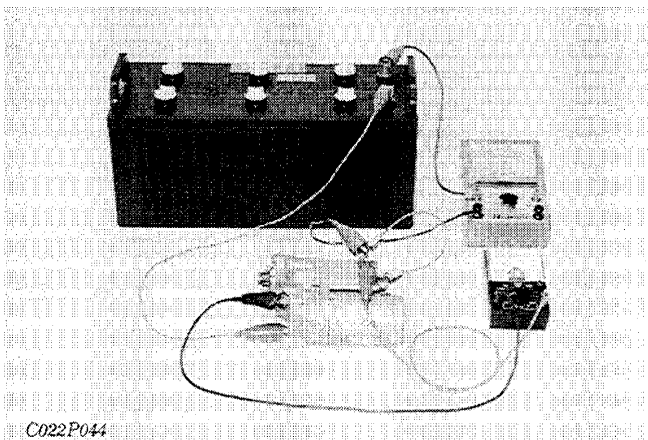

Model	Current	Voltage	Rotational speed
D1102-B D1302-B	45A or less	11.0V	6000min. ¹ (rpm) or more
D1402-B V 1502-B V1702-B V1902-B	90A or less	11.5V	3000min. ¹ (rpm) or more

(A) Electrical connections for no-load testing

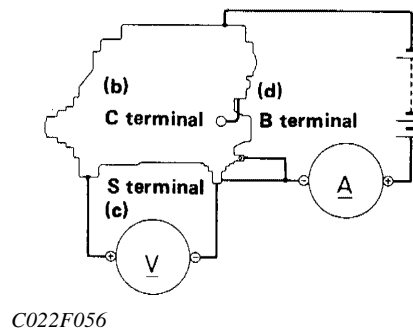
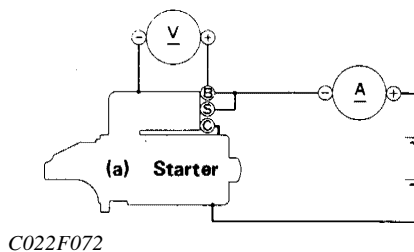

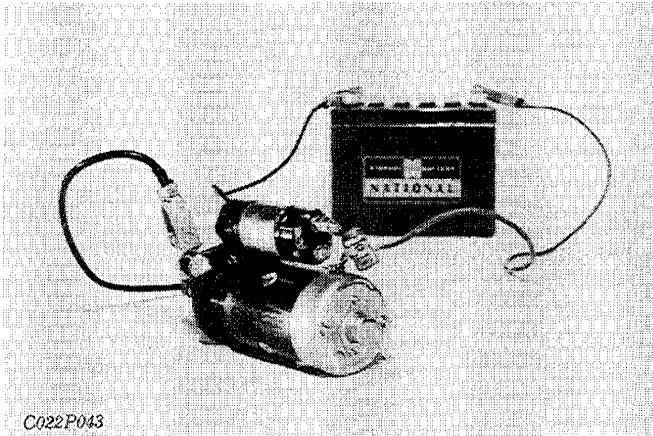

C022P043

f) Motor Test

- 1) Remove the connecting leads from the starter's C terminal and connect them directly to the battery's positive terminal. Then connect the battery's negative terminal to the starter body.
- 2) If the starter runs normally, the magnet switch is defective; if not, the motor is defective.

(A) Electrical connections for motor test

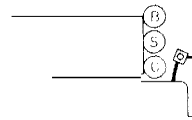

(a) Starter

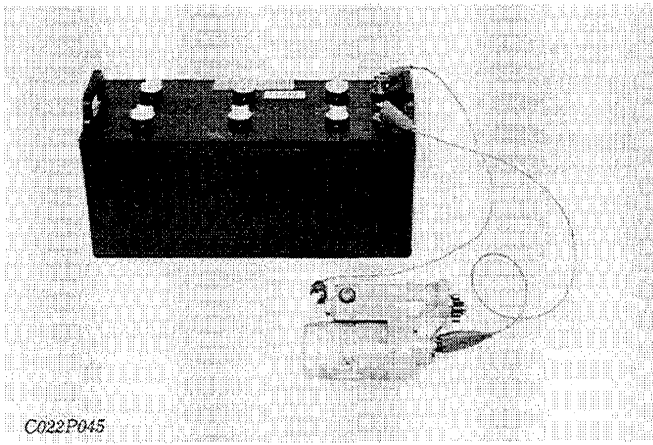

C022P045

C022F073

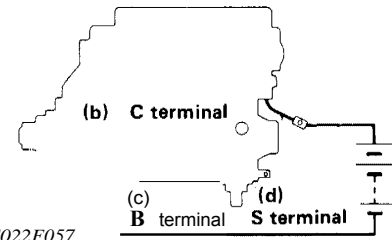

C022F057

Magnet Switch

(1) Pull-In Coil (Attraction Test)

- 1) Apply 1/2 the rated voltage (approx. 6V) across the S terminal and C terminal.
- 2) If the plunger is attracted strongly, the pull-in coil is good; if not, it is defective.

Reference value	The plunger should be attracted strongly
-----------------	--

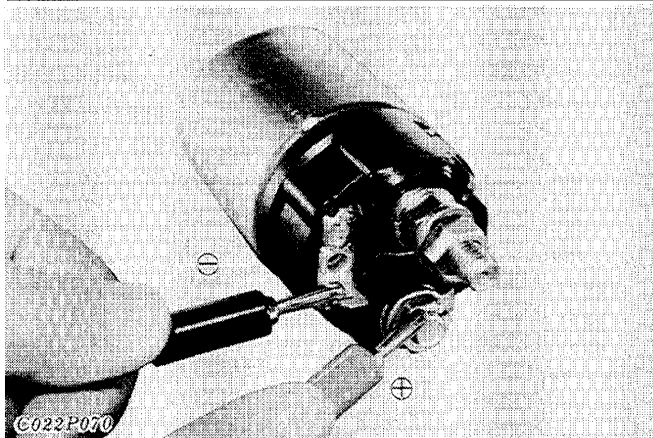

C022P070

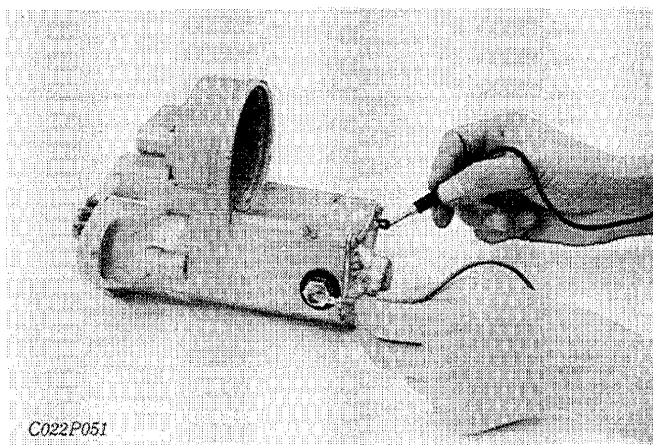

C022P051

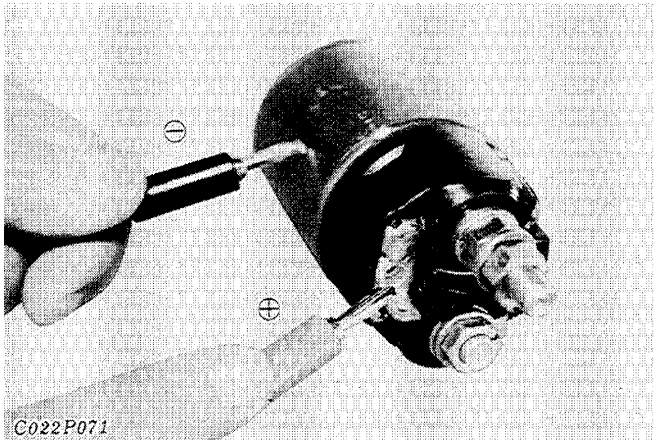

(2) Holding Coil (Retention Test)

- 1) Apply 1/2 the rated voltage (approx. 6V) across the S terminal and the body, push the plunger in by hand, and then release it.
- 2) If the plunger stays attracted, the holding coil is good; if not, it is defective.

Reference value	The plunger remains attracted.
-----------------	--------------------------------

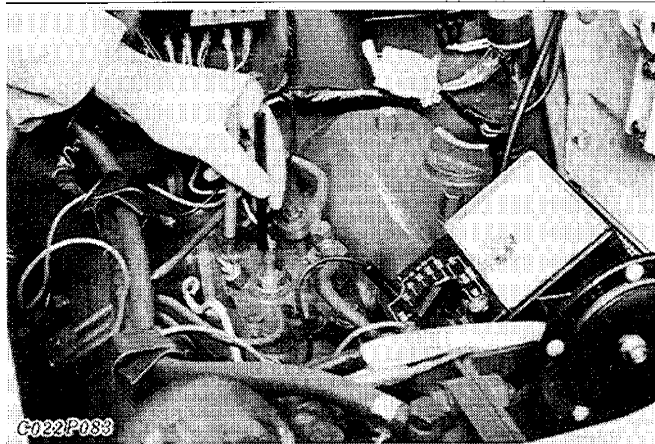
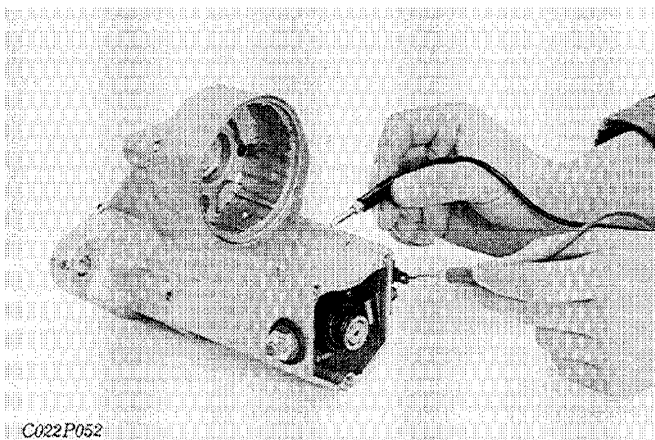

0 Checking Glow Plug

- 1) Disconnect the glow plug cables and leads.
- 2) Connect a circuit tester across the screw of the glow plug end and the body.
 - If the resistance is zero ohms, the glow plug is shorted.
 - If the resistance is infinite, the glow plug coil is broken.

Reference value	Approx. 1.5Ω
-----------------	--------------

DISASSEMBLY AND REASSEMBLY

• MAGNET SWITCH TYPE STARTER

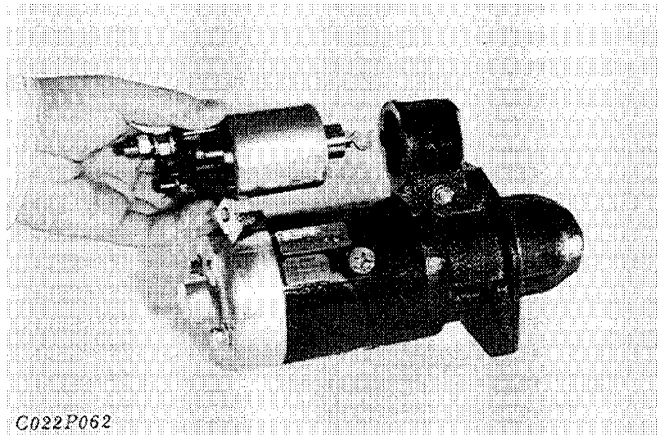

O Removing Magnet Switch

- 1) Remove the connecting lead.
- 2) Remove the set screws.
- 3) Detach the magnet switch by lifting it up while taking care that it does not contact the drive lever.

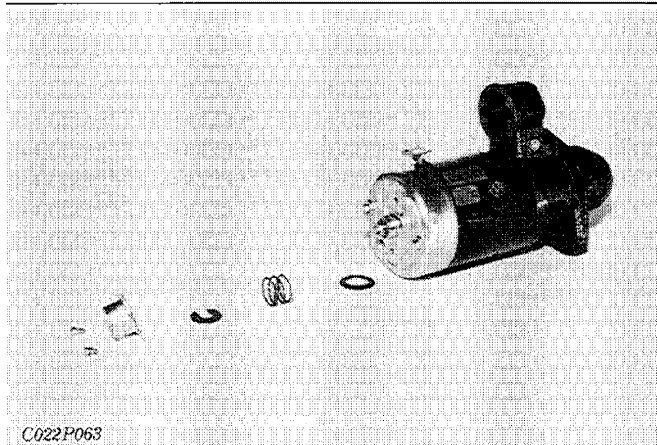

f) Removing Armature Brake

- 1) Remove the end frame cap.
- 2) Remove the washers.
- 3) Remove the packing.

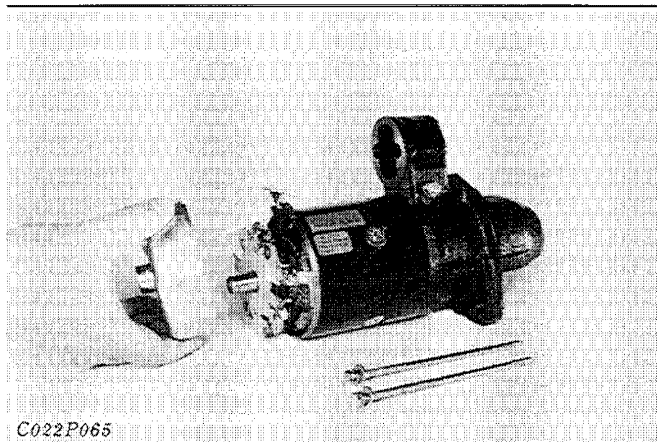

8 Removing End Frame

- 1) Remove the through bolts.
- 2) Remove the end frame.

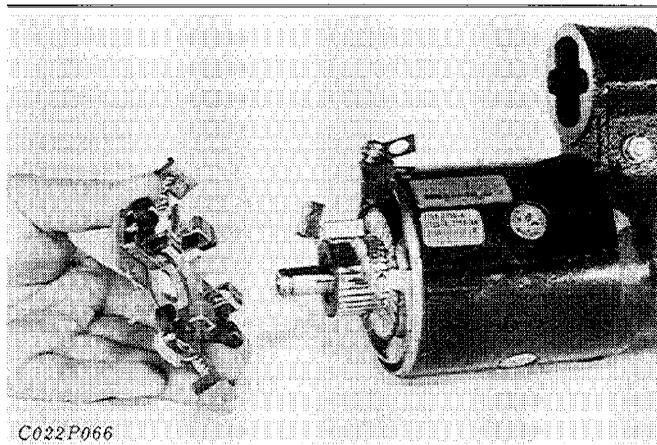

e Removing Brush Holder

- 1) Draw out the brush from the holder while holding the spring up.
- 2) Take off the brush holder.

(Note for reassembly)

- Be sure not to mistake the direction and position of the spring.
- Do not contact the body with the positive brush's lead.

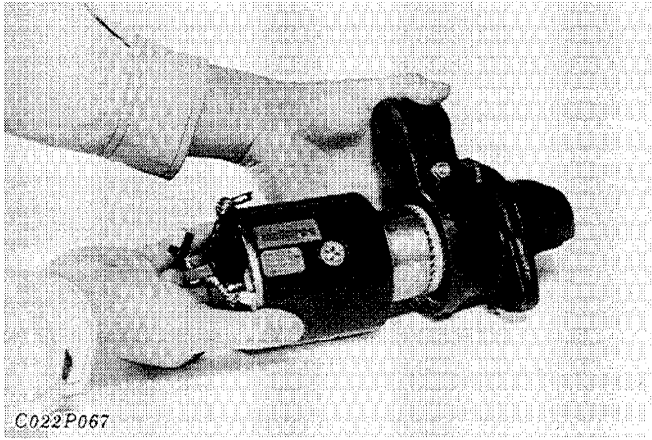

C022P067

Q Removing Yoke

- 1) Draw out the yoke from the drive end frame.

(Note for reassembling)

- Take care for yoke knock pin.

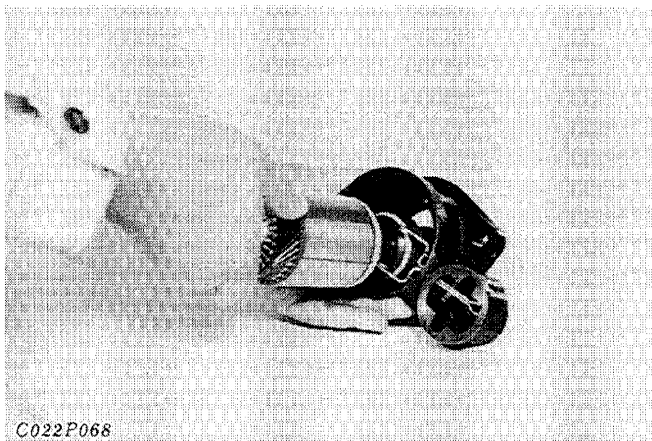

C022P068

O Removing Armature

- 1) Remove the set bolt from the drive lever.
- 2) Draw out the armature from the drive end frame.
- 3) Detach the drive lever.

(Important)

- When reassembling, be sure not to mistake the installing direction of the drive lever.

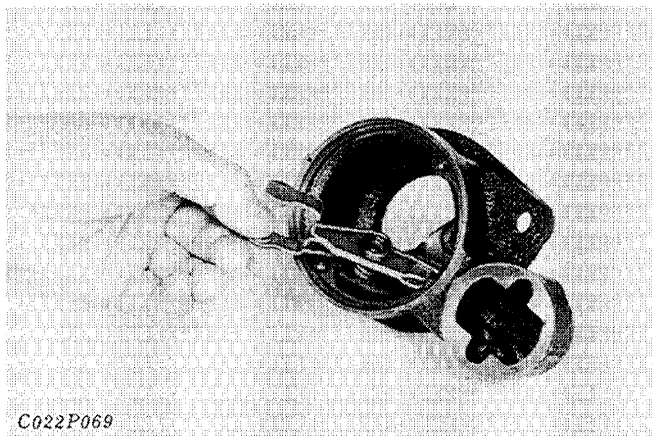

C022P069

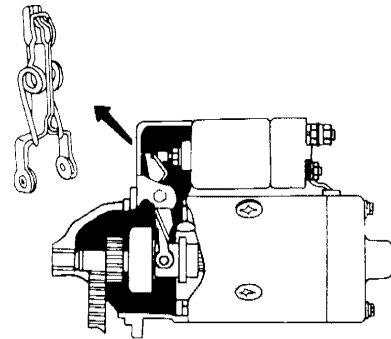

C022F07-1

• REDUCTION TYPE STARTER

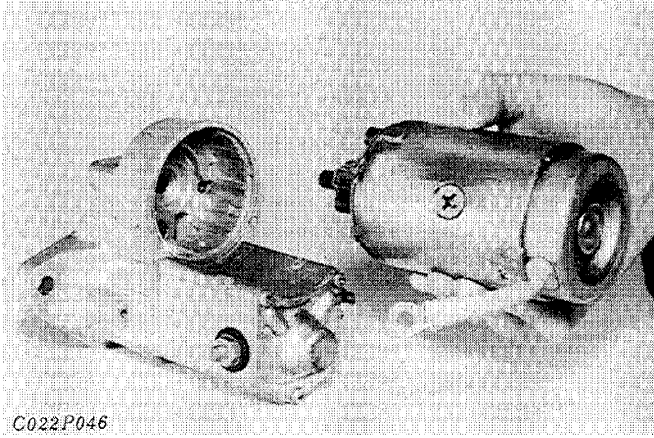

O Removing Motor

- 1) Disconnect the connecting lead.
- 2) Remove the through bolts.
- 3) Remove the motor unit.

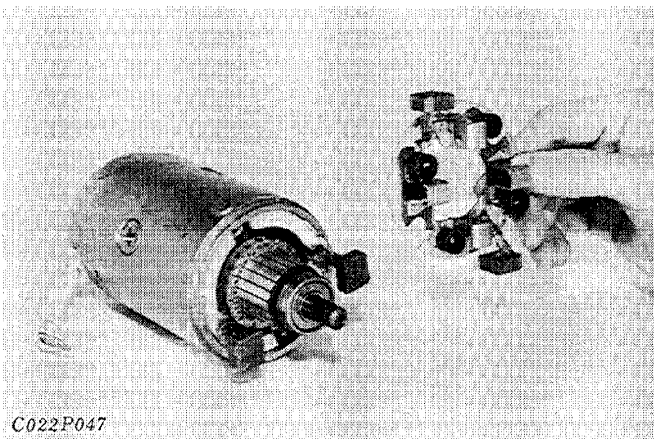

fj Removing Brush Holder

- 1) Release the spring and draw the brush out from the holder.
- 2) Remove the brush holder.

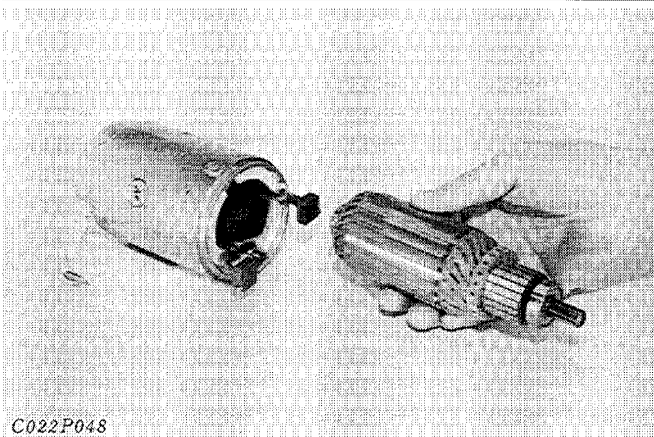

C) Removing Armature

- 1) Draw the armature out.

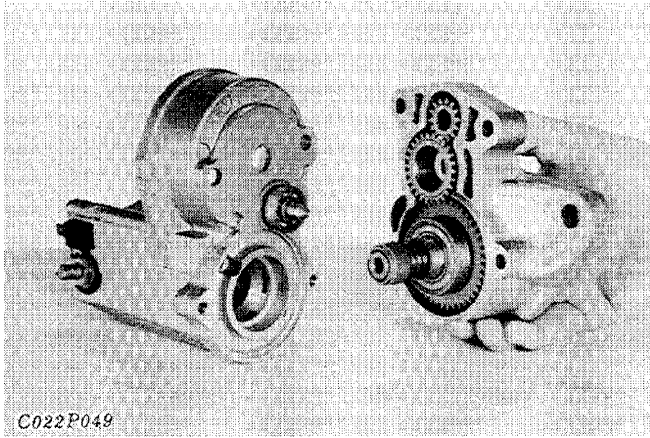

8 Removing Drive End Frame

- 1) Remove the drive end frame.
- 2) Remove the gears (drive pinion, idler gear) and clutch.

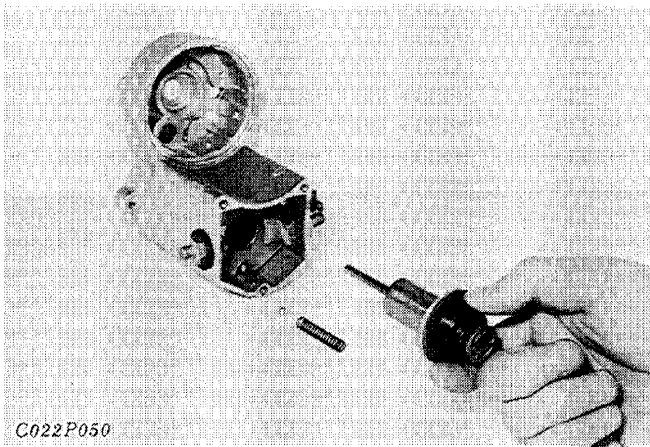

0 Removing Plunger

- 1) Remove the end cover from the magnet switch.
- 2) Draw the plunger out.
- 3) Remove steel balls.

SERVICING

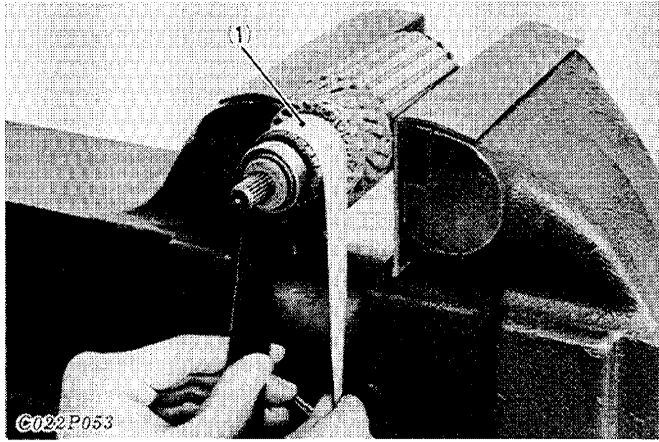

① Staining or Burning of Commutator

- 1) Check to see if the commutator surface is stained or burnt.
- 2) If it is burnt, grind off with fine-grain sand paper.

(1) Sand paper

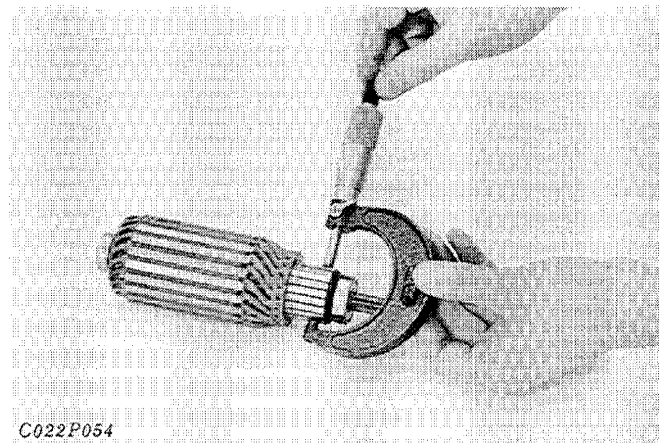

@ Checking Commutator Wear

- 1) Check to see if the contact face of the brush is scored.
- 2) If scored, grind off with sand paper or on a lathe.
- 3) If the commutator diameter must be ground to below the allowable limit, replace it.

Model	Commutator diameter	
	Reference value	Allowable limit
D1102-B D1302-B	32.7 mm 1.2874 in.	32.5 mm 1.2795 in.
D1402-B V1502-B V1702-B V1902-B	30.0 mm 1.1811 in.	29.0 mm 1.1417 in.

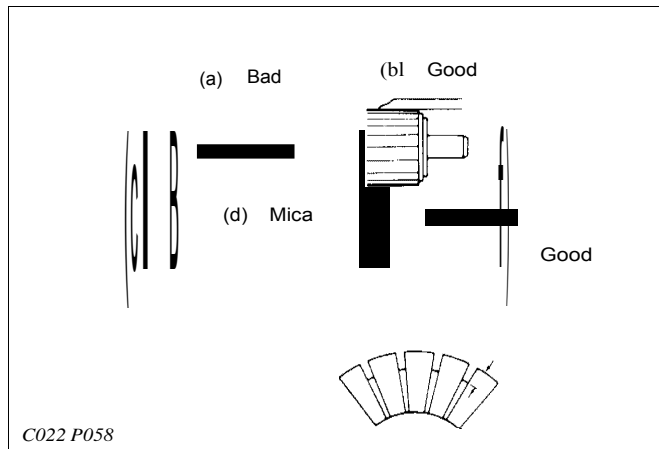

8 Checking Mica(Undercut)

- 1) Check to see the mica undercut.
- 2) If it has high mica, rectify with a saw blade. As the edge of the segment will be rough, chamfer it.

Model	Mica depth	
	Reference value	Allowable limit
01102-B 01302-B	0.5 to 0.8 mm 0.0197 to 0.315 in.	0.2 mm 0.0079 in.
D1402-B V1502-B V1702-B V1902-B	0.5 to 0.9 mm 0.0197 to 0.0354 in.	

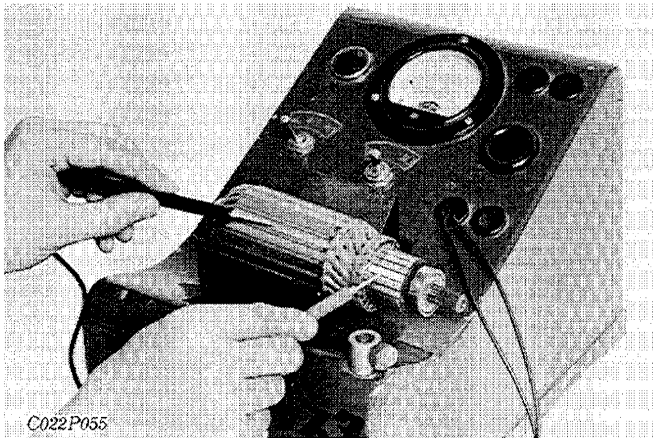

C022P055

0 Grounding of Armature Coil

- 1) Check conduction across the commutator and the armature shaft.
- 2) If conduction, replace.

Reference value	Should not be conducted
-----------------	-------------------------

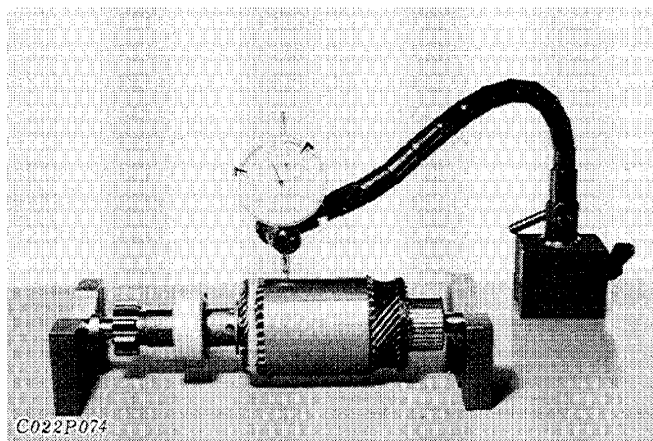

C022P074

0 Checking Armature Flexure

- 1) Measure the amount of flexure; if the measurement exceeds the reference value, replace. Carefully check to see if the core is scratched.

Reference value	0.1 mm 0.0039 in.
-----------------	----------------------

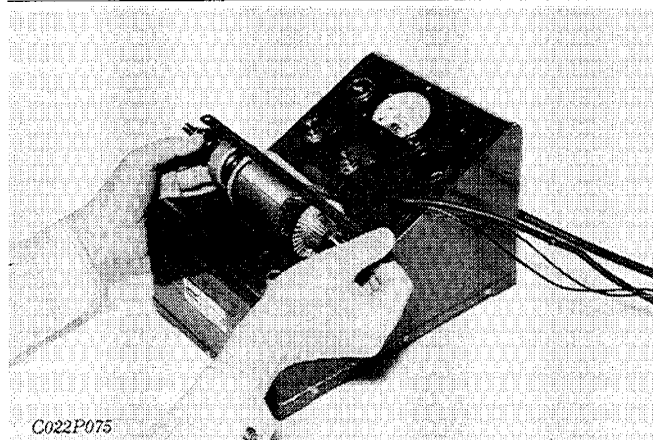

C022P075

C, Checking Armature Coil Short-Circuited

- 1) Set the armature on the armature tester. Rotate the armature while touching it with steel piece.
- 2) If the steel piece starts to vibrate or to be attracted somewhere on the armature, this suggests that the coil contains a layer short at that point.
- 3) If faulty, replace.

Reference value
The armature should not be short-circuited.

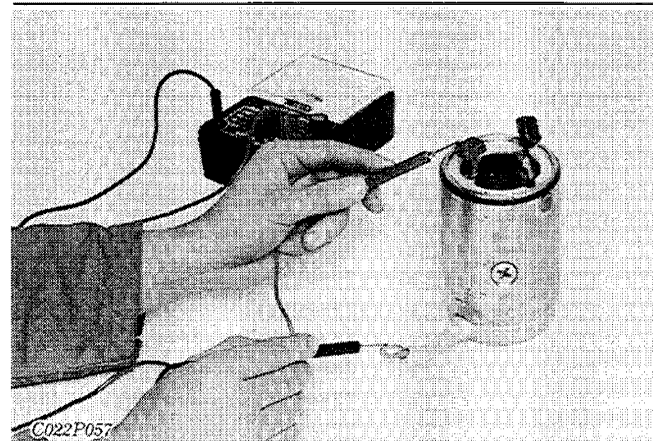

C022P057

@ Checking Field Coil Breakage

- 1) To check conduction, place the tester probes onto the lead and brush.
- 2) If either are not conducting, replace.

Reference value	Should be conducted
-----------------	---------------------

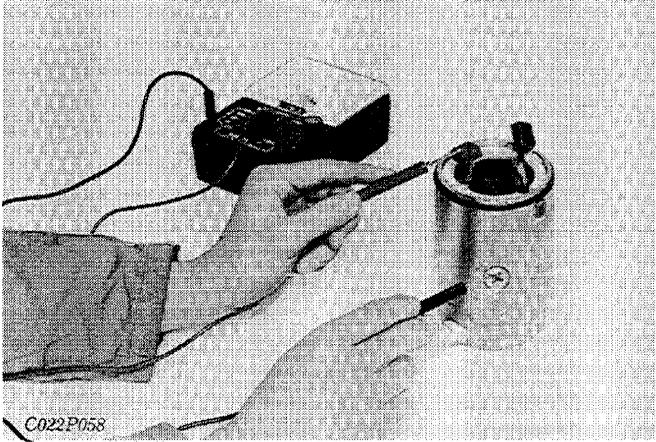

C022P058

(;) Grounding of Field Coil

- 1) To check the conductivity. Place the tester probes onto the field coil and yoke.
- 2) If either are conducting, replace.

Reference value	Should not be conducted
-----------------	-------------------------

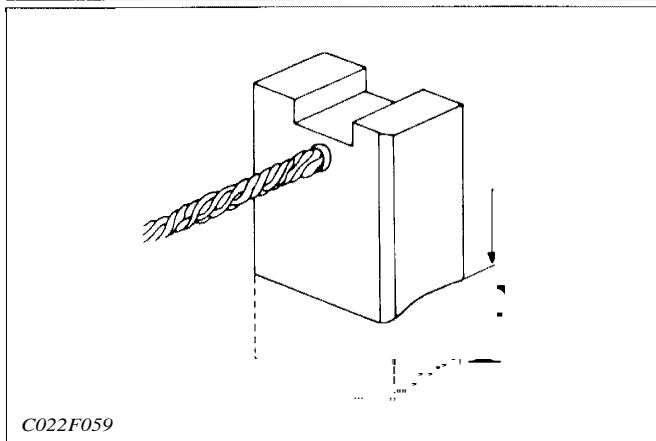

C022F059

CJ) Checking Brush Wear

- 1) Check to see if the brush has worn to more than 2/3 below the standard dimensions.
- 2) If wear exceeds the allowable limit, replace.

Reference value	
Allowable limit	Longer than 12.7 mm

• Starter brush dimensions

Model	Length	Width	Thickness
D1102-B D1302-B	19 mm 0.7480 in.	12 mm 0.4724 in.	7 mm 0.2756 in.
D1402-B V1502-B V1702-B V1402-B	19 mm 0.7480 in.	25 mm 0.9843 in.	8 mm 0.3150 in.

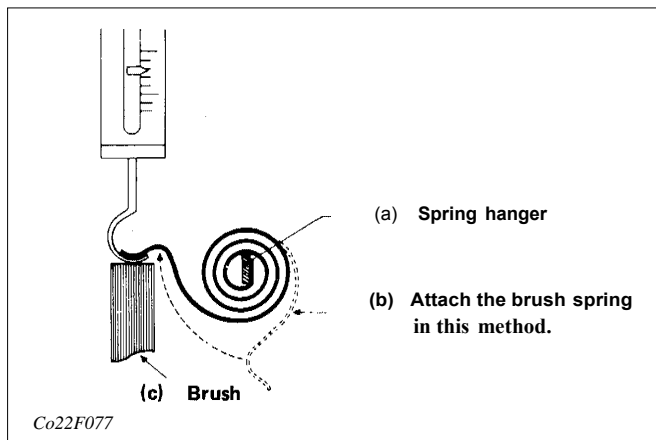

C022F077

Ci) Checking Brush Spring Tension

- 1) Measure the tension with a new brush in place.
- 2) Replace if the tension is under the reference value.

Reference value		
Model	Spring tension	Commutator diameter
O1102-B D1302-B	11.8 N. 1,200 g 2.64 lb	32.7 mm 1.2874 in.
D1402-B V1502-B V1702-B V1902-B	17.5 to 23.7N. 1,785 to 2,415 g 3.94 to 5.33 lb	30.0mm 1.1811in.

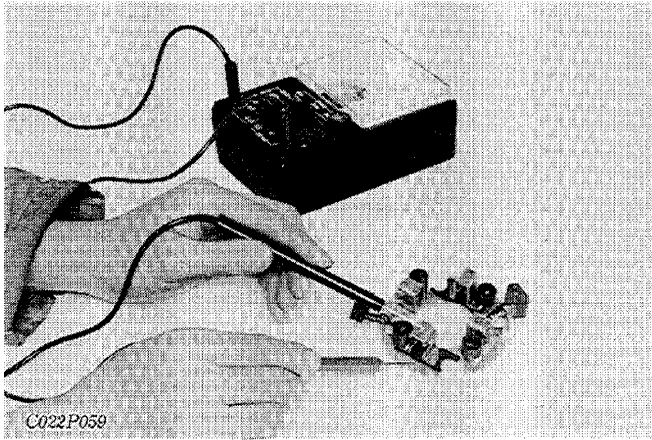

4D Grounding of Brush Holder

- 1) Check the insulation of the positive brush holder.
- 2) If the insulation is defective, replace.

Reference value	Should not be conducted
-----------------	-------------------------

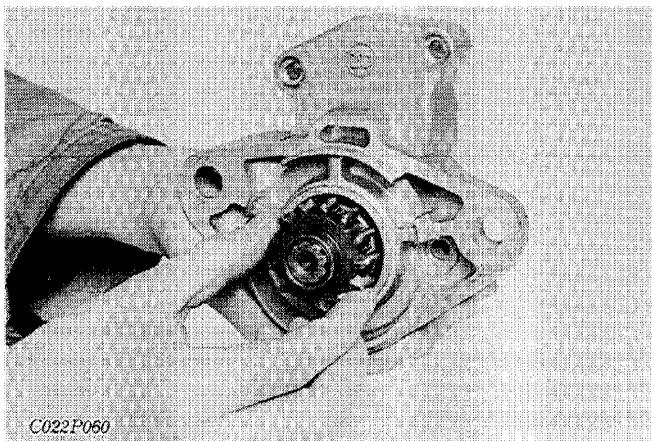

CB Checking Clutch

- 1) Check to see if the clutch gear is worn or damaged.
- 2) Check to see if the gear locks in the driving direction and rotates smoothly in reverse.

(A) Adjustment of pinion gap

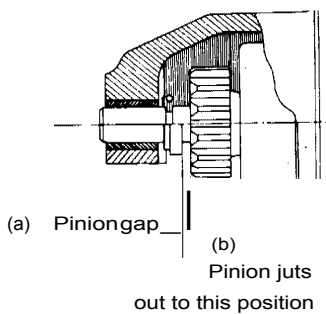

C022F075

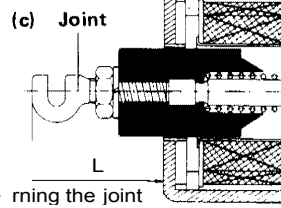

C022F07fi

Checking and Adjusting Pinion Gap (Magnet Switch Type)

- 1) Disconnect the connecting lead from C terminal.
- 2) Energize the magnet switch and measure the gap between the pinion tip and the stop collar.
- 3) To adjust the gap, change the length of the magnet switch joint to the specified one.

Reference value	0.1 to 0.4 mm 0.0039 to 0.0157 in
-----------------	--------------------------------------

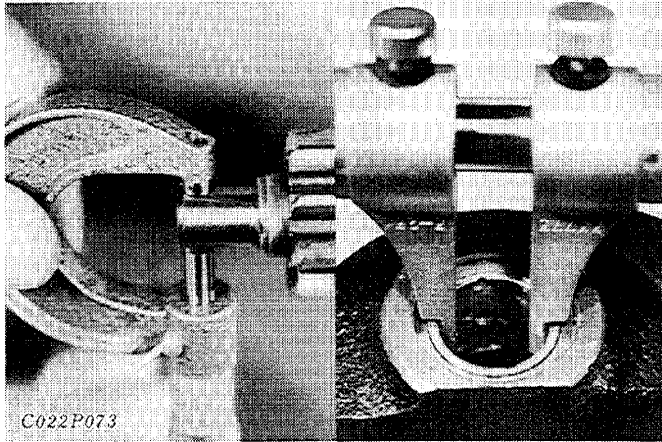

Checking Gap between Shaft and Bush (Magnet Switch Type)

- 1) Measure the inside diameters of the bearing bushings on the side of the drive and commutator.
- 2) Measure the drive-side and commutator-side shaft diameters and calculate the gap.
- 3) If the gap exceeds the allowable limit, use an undersize bush.

■ D1102-B, D1302-B

	Reference value	Allowable limit
Commutator side	0.06 mm 0.0024 in.	0.2 mm 0.0079 in.
Drive side	0.04 mm 0.0016 in.	

	D1102-B, D1302-B
• Diameters of shaft and bush	12.5mm, 0.4921 in.
Commutator side	12.5mm, 0.4921 in.
Drive bushing ID	12.54mm, 0.4937 in.
Commutator bushing ID	12.56mm, 0.4945 in.

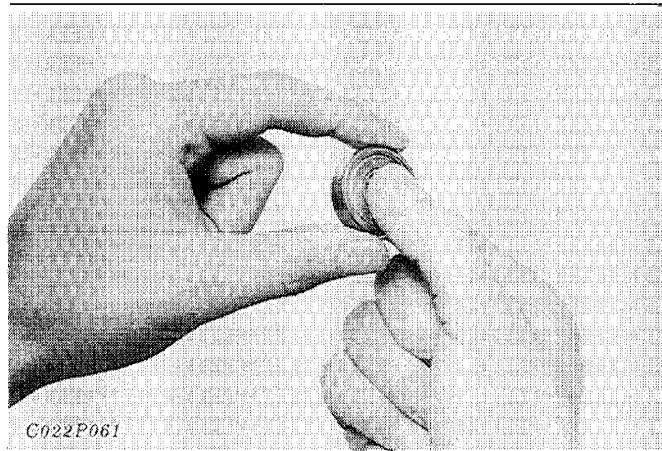

C) Checking Bearing (Reduction Type)

- 1) Apply torque to the inner ring with your fingertips and check to see if it turns smoothly.
- 2) Check to see if there are any strange noises when driven quickly.

Section V

SERVICE DIRECTIONS

Service Directions.....	98
Bolt Torques	102



CYLINDER HEAD

Distortion of cylinder head surface	0.05 mm (0.0020 in.)
Thickness of gasket	1.30 to 1.60 mm (0.0512 to 0.0630 in.)
Thickness of gasket shims	0.2 mm (0.0079 in.)
Top clearance	0.7 to 0.9 mm (0.0276 to 0.0354 in.)

VALVES

* R.V.: Reference Value A.L.: Allowable Limit

Valve seat width		2.1 mm (0.0827 in.)
Valve seat angle		0.785 rad. (45°)
0.0. of valve stems (Intake, Exhaust)		7.960 to 7.975 mm (0.3134 to 0.3140 in.)
1. 0. of valve guides (Intake, Exhaust)		8.015 to 8.030 mm (0.3156 to 0.3161 in.)
Clearance between valve stems and guides	(R.V.)	0.04 to 0.07 mm (0.0016 to 0.0028 in.)
	(A.L.)	0.1 mm (0.0039 in.)
Valve recessing	(R.V.)	1.1 to 1.3 mm (0.0433 to 0.0512 in.)
	(A.L.)	1.6 mm (0.0630 in.)
Valve clearance (Intake, Exhaust)	Cold	0.18 to 0.22 mm (0.0071 to 0.0087 in.)

VALVE SPRINGS

Free length	(R.V.)	41.7 to 42.2 mm (1.6417 to 1.6614 in.)
	(A.L.)	41.2 mm (1.6220 in.)
Fitted length		35.15 mm (1.3839 in.)
Load to compress to fitted length	(R.V.)	117.7 N. (12 kgf., 26.5 lb.)
	(A.L.)	100.0 N. (10.2 kgf., 22.5 lb.)
Squareness		1.0 mm (0.0394 in.)

ROCKER ARMS

0.0. of rocker arm shafts		13.973 to 13.984 mm (0.5501 to 0.5506 in.)
1. 0. of rocker arm bushings		14.002 to 14.043 mm (0.5513 to 0.5529 in.)
1. 0. of rocker arm (Bushless type)		14.002 to 14.043 mm (0.5513 to 0.5529 in.)
Clearance between rocker arm shafts and bushings or rocker arms	(R.V.)	0.018 to 0.070 mm (0.0007 to 0.0028 in.)
	(A.L.)	0.15 mm(0.0059 in.)
Adjustment of compression release		0.750 to 1.125 mm (0.0295 to 0.0443 in.)

CAMSHAFT

O.D. of camshaft bearing journal		39.934 to 39.950 mm (1.5722 to 1.5728 in.)
I.D. of camshaft bearing		40.000 to 40.025 mm (1.5748 to 1.5758 in.)
Clearance between camshaft bearing journals and bearings	(R.V.)	0.050 to 0.091 mm (0.0020 to 0.0036 in.)
	(A.L.)	0.15 mm (0.0059 in.)
Alignment of camshaft	(A.L.)	0.01 mm (0.00039 in.)
Cam height	(Intake) (R.V.)	33.36 mm (1.3134 in.)
	(A.L.)	33.31 mm (1.3114 in.)
	(Exhaust) (R.V.)	33.36 mm (1.3134 in.)
	(A.L.)	33.31 mm (1.3114 in.)
Gear backlash	(R.V.)	0.042 to 0.115 mm (0.0017 to 0.0045 in.)
	(A.L.)	0.15 mm (0.0059 in.)

CYLINDER LINERS

I.D. of cylinder liner	(R.V.)	76.000 to 76.019 mm (2.9921 to 2.9929 in.)	82.000 to 82.022 mm (3.2283 to 3.2292 in.)	85.000 to 85.022 mm (3.3465 to 3.3473 in.)	76.000 to 76.019 mm (2.9921 to 2.9929 in.)	82.000 to 82.022 mm (3.2283 to 3.2292 in.)	85.000 to 85.022 mm (3.3465 to 3.3473 in.)
	(A.L.)	+0.15 mm (+0.0059 in.)					

PISTON RINGS

(Top ring, 2nd ring)	(R.V.)	0.30 to 0.45 mm (0.0118 to 0.0177 in.)
	(A.L.)	1.25 mm (0.0492 in.)
Ring gap (Oil ring)	(R.V.)	0.25 to 0.45 mm (0.0098 to 0.0177 in.)
	(A.L.)	1.25 mm (0.0492 in.)
Side clearance of ring in groove	(Top ring)	-----
	(2nd ring)	0.093 to 0.120 mm (0.0037 to 0.0047 in.)
	(Oil ring)	0.020 to 0.052 mm (0.0008 to 0.0020 in.)
Oversizes of piston and ring		0.5 mm (0.0197 in.)

PISTONS

I.D. of piston bosses	(R.V.)	23.000 to 23.013 mm (0.9055 to 0.9060 in.)
	(A.L.)	23.053 mm (0.9076 in.)
O.D. of piston pin		23.002 to 23.011 mm (0.9056 to 0.9059 in.)
I.D. of connecting rod small end bushings (fitted)		23.025 to 23.040 mm (0.9065 to 0.9071 in.) [Service Part 23.026 to 23.069 mm (0.9065 to 0.9082 in.)]
Clearance between piston pin and small end bushings	(R.V.)	0.014 to 0.038 mm (0.0006 to 0.0015 in.) [Service Part 0.015 to 0.067 mm (0.0006 to 0.0026 in.)]
	(A.L.)	0.15 mm (0.0059 in.)
Connecting rod small end parent bore dia.		26.000 to 26.013 mm (1.0236 to 1.0241 in.)
Connecting rod alignment	(R.V.)	0.02 mm (0.0008 in.)
	(A.L.)	0.05 mm (0.0020 in.)

CRANKSHAFT

* R.V.: Reference Value A.L.: Allowable Limit

Crankshaft alignment	(R.V.)	0.02 mm (0.0008 in.)	
	(A.L.)	0.08 mm (0.0031 in.)	
O.D. of crankshaft journals		51.921 to 51.940 mm (2.0441 to 2.0449 in.)	
I.D. of crankshaft bearing 1		51.980 to 52.039 mm (2.0465 to 2.0488 in.)	
I.D. of crankshaft bearing 2		51.980 to 52.025 mm (2.0465 to 2.0482 in.)	
Clearance between crankshaft journal and bearing 1	(R.V.)	0.040 to 0.118 mm (0.0016 to 0.0046 in.)	
	(A.L.)	0.20 mm (0.0079 in.)	
Clearance between crankshaft journals and bearing 2	(R.V.)	0.040 to 0.104 mm (0.0016 to 0.0041 in.)	
	(A.L.)	0.20 mm (0.0079 in.)	
Undersizes of crankshaft bearing 1		0.2 mm (0.0079 in.)	0.4 mm (0.0157 in.)
Undersizes of crankshaft bearing 2		0.2 mm (0.0079 in.)	0.4 mm (0.0157 in.)
O.D. of crankpins		43.959 to 43.975 mm (1.7307 to 1.7313 in.)	
I.D. of crankpin bearings		44.010 to 44.052 mm (1.7327 to 1.7343 in.)	
Clearance between crankpins and bearings	(R.V.)	0.035 to 0.093 mm (0.0014 to 0.0037 in.)	
	(A.L.)	0.20 mm (0.0079 in.)	
Undersizes of crankpin bearings		0.2 mm (0.0079 in.)	0.4 mm (0.0157 in.)
End play of crankshaft	(R.V.)	0.15 to 0.31 mm (0.0059 to 0.0122 in.)	
	(A.L.)	0.5 mm (0.0197 in.)	
Oversizes of crankshaft side metal 1.2		0.2 mm (0.0079 in.)	0.4 mm (0.0157 in.)

FUEL INJECTION NOZZLES

Opening pressure	13.7 to 14.7 MPa. (140 to 150 kgf/cm ² 1990.8 to 2133.0 lb./sq.in.)
Fuel tightness of nozzle valve seat	Dry nozzle at 12.7 to 13.7 MPa. (130 to 140 kgf/cm ² , 1848.6 to 1990.8 lb./sq.in.)

INJECTION PUMP

Fuel tightness of plunger	(R.V.)	8 seconds or more; initial pressure from 9.8 MPa. to 490.3 kPa. (600 to 500 kgf/cm ² , 8532.0 to 7110.0 lb./sq.in.)	
	(A.L.)	4 seconds or less	
Fuel tightness of delivery valve	(R.V.)	10 seconds or more; initial pressure from 9.8 to 0.5 MPa. (100 to 5 kgf/cm ² , 1422.0 to 71.1 lb./sq. in.)	
	(A.L.)	5 seconds or less	
Injection timing		0.401 to 0.436 rad. (23 to 25°) before TDC	

OIL PUMP

Oil pressure (Normal running)	(R.V.)	294.2 to 441.3 kPa. (3.0 to 4.5 kgf/cm ² , 42.7 to 64.0 lb./sq. in.)	
	(A.L.)	245.2 kPa. (2.5 kgf/cm ² , 35.6 lb./sq. in.)	
Rotor lobe clearance	(R.V.)	0.10 to 0.16 mm (0.0039 to 0.0063 in.)	0.04 to 0.13 mm (0.0016 to 0.0051 in.)
	(A.L.)	0.20 mm (0.0079 in.)	
ROTOR TYPE Radial clearance between outer rotor and pump body	(R.V.)	0.11 to 0.19 mm (0.0043 to 0.0075 in.)	
	(A.L.)	0.25 mm (0.0098 in.)	
End clearance between rotor and cover	(R.V.)	0.105 to 0.150 mm (0.0041 to 0.0059 in.)	
	(A.L.)	0.2 mm (0.0079 in.)	

RADIATOR

Opening pressure of cap	88.3 kPa. (0.9 kgf/cm ² , 12.8 lb./sq. in.)
Test pressure	88.3 kPa. (0.9 kgf/cm ² , 12.8 lb./sq. in.)

THERMOSTAT

Opening temperature	(beginning) 80.5°C to 83.5°C (176.9°F to 182.3°F)
	(full-open) 95°C (203°F)
Distance of lift	8 mm (0.3150 in.)

FANBELT

Belt sag under load of 98N. (10 kgf.,221b.)	10 to 12 mm (0.394 to 0.472 in.)
--	----------------------------------

ALTERNATOR

Output current	25 A/14 V /4000 min ⁻¹ (rpm)
Total resistance of rotor coil, measured	6Ω
between terminal "F" and "E"	0Ω
Brush length	15.5 mm (0.6102 in.)
	10.3 mm (0.4055 in.)

REGULATOR

Cut-in voltage	4.5 to 5.8 V
No-load regulating voltage	13.8 to 14.8 V
Resistance between terminals:	0Ω
"IG" and "F" with open contacts	
"IG" and "F" with contacts	Approx. 11 Ω
"L" and "E" with open contacts	0Ω
"L" and "E" with contacts	Approx. 100 Ω
"N" and "E"	Approx. 23 Ω
"B" and "E" with open contacts	Infinity
"8" and "L" with contacts	0Ω
Point gap	0.3 to 0.45 mm (0.0118 to 0.0177 in.)

STARTER MOTOR

	Current	45 A or less	90 A or less
No-load test	Voltage	11 V	11.5 V
	Speed	6000min ⁻¹ (rpm) or more	3500 min ⁻¹ (rpm) or more
O.D. of commutator	(R.V.)	32.7 mm (1.2874 in.)	30.0 mm (1.1811 in.)
	(A.L.)	32.5 mm (1.2795 in.)	29.0 mm (1.1417 in.)
Mica undercutting	(R.V.)	0.5 to 0.8 mm (0.0917 to 0.0315 in.)	0.5 to 0.9 mm (0.0197 to 0.0354 in.)
	(A.L.)	0.2 mm (0.0079 in.)	
Brush length	(R.V.)	19 mm (0.7480 in.)	
	(A.L.)	12.7 mm (0.5000 in.)	

GLOW PLUG

Resistance	Approx. 1.5 Ω
------------	---------------

Bolt Torques

Material Grade	Standard Bolt	Special Bolt	Special Bolt
	Nominal Dia.	SS41, S20C	S43C, S48C (Refined)
M 6	7.8 9.3 N·m 0.80 0.95 kgf·m 5.8 – 6.9 lb.ft.	9.8 – 11.3 N·m 1.00 1.15 kgf·m 7.2 – 8.3 lb.ft.	12.3 14.2 N·m 1.25 1.45 kgf·m 9.0 – 10.5 lb.ft.
M 8	17.7 – 20.6 N·m 1.80 2.10 kgf·m 13.0 – 15.2 lb.ft.	23.5 27.5 N·m 2.40 2.80 kgf·m 17.4 20.3 lb.ft.	29.4 – 34.3 N·m 3.00 3.50 kgf·m 21.7 – 25.3 lb.ft.
M10	39.2 45.1 N·m 4.00 – 4.60 kgf·m 28.9 – 33.3 lb.ft.	48.0 – 55.9 N·m 4.90 5.70 kgf·m 35.4 – 41.2 lb.ft.	60.8 – 70.6 N·m 6.20 – 7.20 kgf·m 44.8 – 52.1 lb.ft.
M12	62.8 72.6 N·m 6.40 7.40 kgf·m 46.3 53.5 lb.ft.	77.5 – 90.2 N·m 7.90 9.20 kgf·m 57.1 – 66.5 lb.ft.	103.0 117.7 N·m 10.50 12.00 kgf·m 75.9 – 86.8 lb.ft.
M14	107.9 – 125.5 N·m 11.00 – 12.80 kgf·m 79.6 – 92.6 lb.ft.	123.6 – 147.1 N·m 12.60 15.00 kgf·m 91.1 – 108.5 lb.ft.	166.7 – 196.1 N·m 17.00 – 20.00 kgf·m 123.0 – 144.7 lb.ft.
M16	166.7 – 191.2 N·m 17.00 19.50 kgf·m 123.0 – 141.0 lb.ft.	196.1 225.5 N·m 20.00 23.00 kgf·m 144.7 – 166.4 lb.ft.	259.9 304.0 N·m 26.50 31.00 kgf·m 191.7 – 224.2 lb.ft.
M18	245.2 284.4 N·m 25.00 – 29.00 kgf·m 180.0 – 209.8 lb.ft.	274.6 318.7 N·m 28.00 – 32.50 kgf·m 202.5 – 235.1 lb.ft.	343.2 – 402.0 N·m 35.00 – 41.00 kgf·m 253.2 296.5 lb.ft.
M20	333.4 392.2 N·m 34.00 40.00 kgf·m 245.9 – 289.3 lb.ft.	367.7 – 431.5 N·m 37.50 44.00 kgf·m 271.2 – 318.2 lb.ft.	490.3 – 568.7 N·m 50.00 58.00 kgf·m 361.6 – 419.5 lb.ft.

Bolt material grades are shown by numbers punched on the bolt heads. Prior to tightening, be sure to check out the numbers as shown below:

Punched Number	Bolt Material Grade
None	Standard Bolts SS41, S20C
7	Special Bolts S43C, S48C (Refined)
9	Special Bolts SCM3, SCR3 (Refined)

EDITOR:

KUBOTA FARM & INDUSTRIAL MACHINERY SERVICE, LTD.

64, ISHIZU-KITAMACHI, SAKAI-KU, SAKAI-CITY, OSAKA, 590-0823, JAPAN

PHONE : (81)72-241-1129

FAX : (81)72-245-2484

E-mail : ksos-pub@kubota.co.jp
